

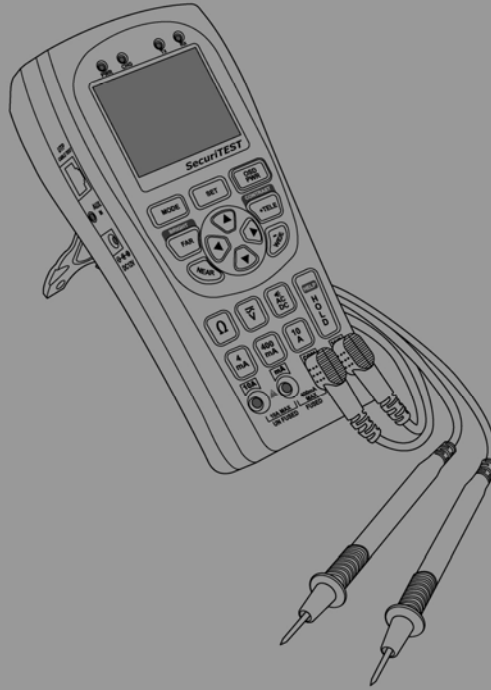

# SecuriTEST™

User's Manual





---

## **SecuriTEST User's Manual**

### **Table of Contents**

---

Before Using SecuriTEST .....	2
SecuriTEST Safety Precautions .....	3
Battery Charging Precautions .....	5
Standard Accessories.....	8
Names & Functions.....	9
General Specifications .....	14
Meter Specifications .....	15
Digital Multi-Meter .....	23
PTZ Controller.....	30
UTP Cable Tester.....	36
View Information.....	38



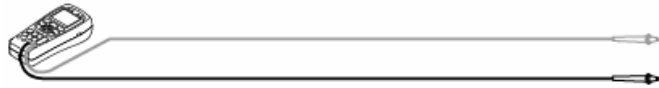

## Before Using SecuriTEST

### WARNING

Read the “Safety Information” portion of the manual before using the SecuriTEST CCTV tester.

This manual is for users of the IDEAL SecuriTEST multi-function CCTV tester. The manual describes the operation and function of the various features of SecuriTEST.

It is highly recommended that operators read the entire manual before using SecuriTEST to prevent damage to the tester or injury to the operator.



## ⦿ **SecuriTEST Safety Precautions**

When using the Digital MultiMeter function to measure voltage or current, be sure that the input does not exceed the capabilities of the tester. Overloading the tester can cause damage or personal injury.

When measuring current of unknown values, always begin with the 10A mode, then step down to the 400mA input if necessary.

### Environmental Limitations

Temperature:	-10 to 50 degrees C 14 to 122 degrees F
Relative Humidity:	0-90%, non-condensing
DC input voltage:	12V +/-10%, 1A

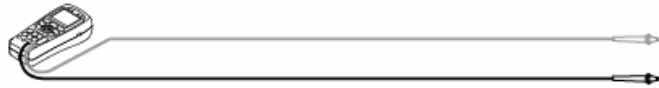

## 1. SAFETY INFORMATION

Do not use the unit in damp conditions or environments where explosive gases may be present.

Do not handle the unit with wet hands.

Avoid dropping or causing mechanical shock to the unit.

Do not expose the ports to liquids and avoid exposure to dust.

Use only specified replacement fuses.

Do not use damaged test leads with the DMM.

Do not measure resistance on powered circuits.

When using the DMM function, set the proper mode before connecting to the circuit under test.

When measuring resistance, make certain that the circuit is de-energized before connecting the test leads to the circuit.

## 1. SAFETY INFORMATION



### ⦿ Battery Charging Precautions

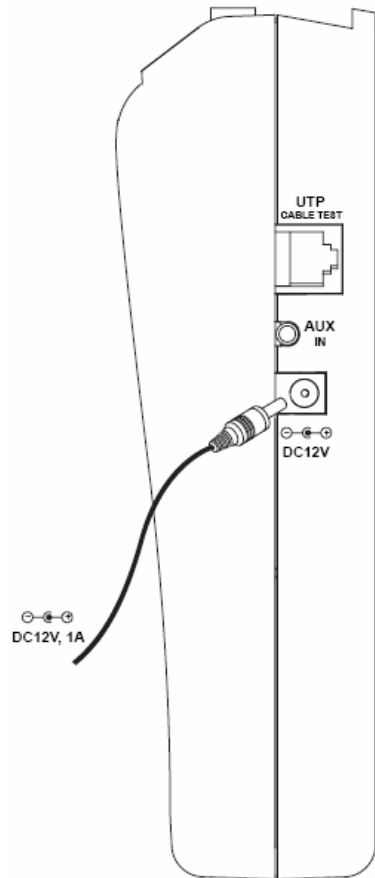

SecuriTEST is capable of recharging NiMH batteries installed in its battery compartment.

To charge the batteries attach the included 12V adapter to the handset and set the main power switch to the ON position. Charging time takes 8 hours. Although the charge LED will light regardless of the position of the power switch, charging will only occur with the switch in the ON position. Operation time is approximately 3-4 hours on a fully charged set of batteries.

When using alkaline batteries the tester can run for approximately 2 hours on a new set of batteries.

When using alkaline batteries, set the switch inside the battery compartment to OFF to prevent accidental charging of alkaline batteries.

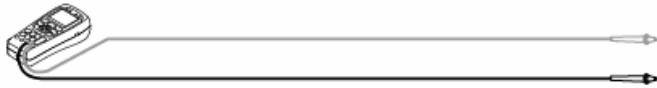

## - Battery Precautions -

The following batteries can be used with SecuriTEST:

- > AA size alkaline batteries
- > AA size rechargeable nickel metal hydrogen (Ni-MH) batteries

### When charging batteries in SecuriTEST:

Place both the MAIN POWER and the CHARGE SWITCH to the "ON" position. The charge LED will light when the MAIN POWER SWITCH is in either position, but the batteries will charge only when the switch is set to "ON".

The CHARGE SWITCH is located on the upper part of battery compartment. (*Refer to the figure below*)

The performance of batteries can be very different, depending on manufacturers. Please use any reputable brand for best performance. Do not mix batteries of different manufacturers when charging batteries. Make sure not to reverse the polarization of the batteries. Do not short-circuit or disassemble batteries. Make sure to check the polarization, voltage and current ratings before charging batteries. Immediately disconnect the charger should an abnormal situation arise.

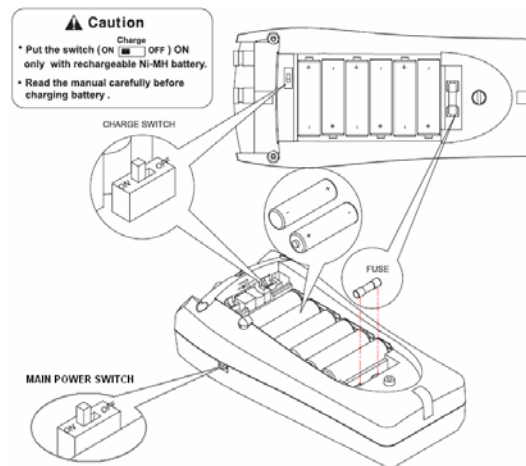

## FEATURES

SecuriTEST is a portable device for testing and troubleshooting various functions of CCTV cameras. It includes functions to test video image quality, control PTZ operation, analyzes various PTZ protocols, generates video test patterns, test UTP cables and includes a full-function Digital MultiMeter.

All functions are controlled through the front keypad and on-screen display for quick and easy setup of fixed and PTZ camera systems.

### 2. SecuriTEST Introduction

- |                |                                                                                                                                                                                                                                                                                                                                                                                                                                                          |
|----------------|----------------------------------------------------------------------------------------------------------------------------------------------------------------------------------------------------------------------------------------------------------------------------------------------------------------------------------------------------------------------------------------------------------------------------------------------------------|
| Video Tester   | <ul style="list-style-type: none"><li>▶ Displays the output signal from the connected CCTV camera. Used to adjust aim and adjust and troubleshoot cameras.</li><li>▶ Video signal generator mode: Outputs color bars and Red, Blue and Green screens to allow technicians to configure monitors and troubleshoot cameras by sending a known good video signal down a questionable coax run. Supports both PAL &amp; NTSC video signal formats.</li></ul> |
| MultiMeter     | <ul style="list-style-type: none"><li>▶ Measures resistance, AC/DC voltage and current, and provides continuity beep and display hold functions.</li></ul>                                                                                                                                                                                                                                                                                               |
| PTZ Controller | <ul style="list-style-type: none"><li>▶ The PTZ controller tests the movement of the dome and allows manual zoom and manual focus control of the camera. Supports various RS-485 and RS-422</li></ul>                                                                                                                                                                                                                                                    |





protocols to allow operation with a variety of camera manufacturers.

**UTP Cable Tester** ► The UTP cable check tests unshielded cables for continuity, opens, shorts and mis-wired pairs.

## Standard Accessories

The following items are included with the SecuriTEST CCTV Tester.



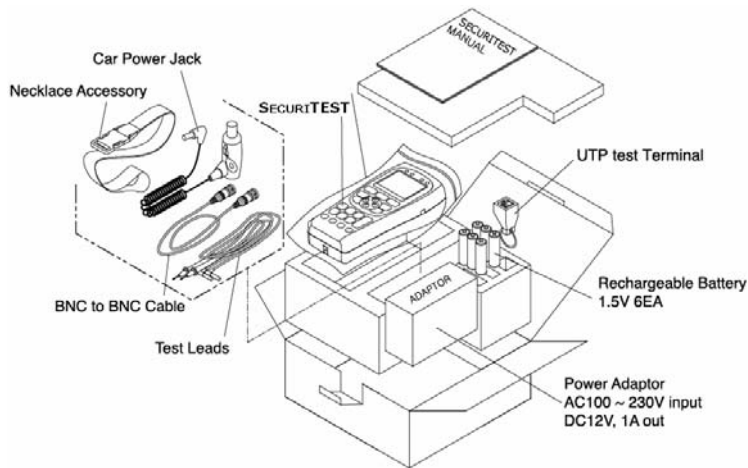



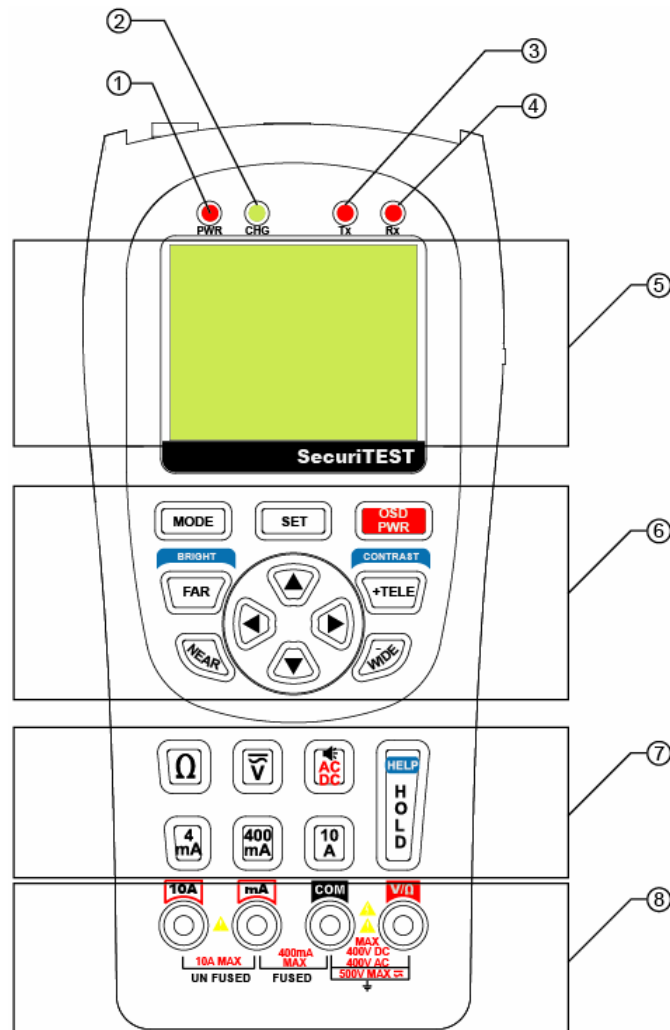

- SecuriTEST Handset
- User's Manual
- DMM Test Lead Set (Red, Black)
- AC Adapter with international plug adapters
- Rechargeable AA Nickel Metal Hydride (Ni-MH) Battery (6ea)
- Neck Strap
- UTP test Terminator
- BNC Video Cable
- Car Power Jack (12VDC)

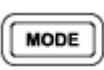











## Names & Functions





Part	Name	Function
①	Power LED	Red LED is on when the system is switched on
②	Charge LED	Green LED is on when AC adapter connected
③	Data Transmitting LED	Red LED is on when PTZ data is transmitted
④	Data Receiving LED	Red LED is on when PTZ data is received
⑤	LCD	2.5" Color TFT LCD
⑥	Keypad	Main keypad for SecuriTEST operation
	MODE Button	Mode Select: Video, MultiMeter, PTZ Control, UTP Test (press and hold to display main menu)
	SET Button	Used to confirm selection in menu screens. Press and hold to access PTZ protocol menu
	OSD Button	Press to toggle on-screen display on or off. Press and hold to turn off power.
	FAR Button	Adjusts PTZ focus (far direction) & Video Mode Brightness
	NEAR Button	Adjust PTZ focus (near direction) & Video Mode Brightness
	TELE Button	Zoom PTZ (zoom in) & Adjusts Video Mode Contrast
	WIDE Button	Zoom PTZ (zoom out) & Adjusts Video Mode Contrast
	Direction Keys	Moves up, down, right, left for PTZ & for menus

Part	Name	Function
⑦	MultiMeter Keys	Selects functions of Digital MultiMeter
	Resistance Button	Selects Resistance Mode
	Voltage Button	Selects Voltage Mode
	Setup Change Button	Toggles AC/DC Mode & Selects Continuity Test
	Current Measuring Button 1	Selects low Current (below 4mA) Mode
	Current Measuring Button 2	Selects Current (below 400mA) Mode
	Current Measuring Button 3	Selects Current (up to 10A) Mode
	HOLD, HELP Button	Locks Auto-Ranging Function. Hold for HELP
⑧	Test Lead Connection	Ports for Digital MultiMeter
		Voltage & Resistance Port
		Common Port
		Current Measurement below 400mA Port
		Current Measurement up to 10A Port

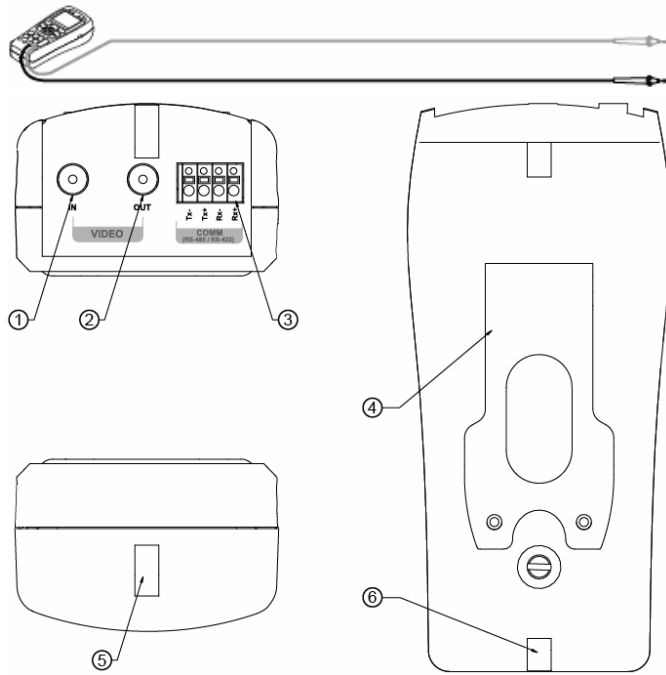

PART	NAME	FUNCTION
①	Input BNC	Connect to camera output to display image on screen
②	Output BNC	Use as pass-through port for camera image or to output video test signal to external monitor
③	Communication Port	Input & Output of PTZ communications signals
④	Kickstand	Holds unit upright when extended
⑤	Neck-strap Hook	Connect neck-strap here to hang unit
⑥	Neck-strap Hook	Can be used to hang the unit upside down

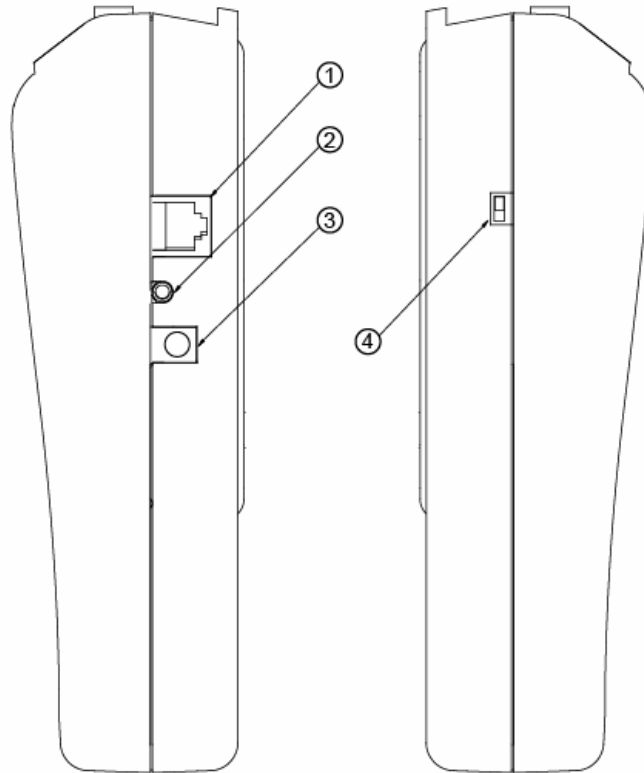

PART	NAME	FUNCTION
①	UTP Jack	Test jack for UTP Cable w/ RJ45 plug
②	AUX Jack	Audio, AUX Input Port (for future use)
③	DC Power Jack	DC Power Input Jack (DC12V, 1A)
④	Power Switch	Main Power Supply ON/OFF switch

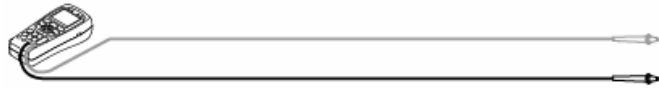

### 3. SECURITEST SPECIFICATIONS

#### • General Specifications

<b>Electric Characteristics</b>	Input Voltage	12V ± 10% above 1A	
	Battery	Rechargeable Ni-MH battery 6ea (AAsize)	
	Built-in Charger	Charging Time	Above 8 hrs
		Operation Time	> 3 hrs
<b>Image</b>	TV Type	NTSC / PAL	
	Image Level	1 Vpp, 140IRE	
<b>PTZ Operation Test</b>	Protocol	Multi-Protocol support	
	Transmission Speed	2400bps ~ 38400bps	
	Transmission Mode	RS-422, RS-485	
<b>UTP Cable Test</b>	Test	Direct / Cross Cable, and Broken or Short-Circuit	
<b>Size</b>	W 3.5" (88mm) X L 7.9" (190mm) X H 2.3" (58mm)		

### 3. SECURITEST SPECIFICATIONS

#### ● Meter Specifications

Measuring Item	Measured Value	Minimum Measuring	Accuracy	
DC Voltage	400mV	100uV	$\pm (0.8\% + 2\text{dgts})$	
	4V	1mV	$\pm (1.0\% + 2\text{dgts})$	
	40V	10mV		
	400V	100mV		
AC Voltage	4V	1mV	$\pm (1.2\% + 3\text{dgts})$ (40Hz ~ 500Hz)	
	40V	10mV		
	400V	100mV		
DC Current	4mV	400uA	0.2uA	$\pm (1.0\% + 2\text{dgts})$
		4mA	2uA	
	400mV	40mA	20uA	$\pm (1.5\% + 2\text{dgts})$
		400mA	200uA	
	10A	10A	2mA	$\pm (2.0\% + 3\text{dgts})$







Measuring Item	Measured Value		Minimum Measuring	Accuracy
AC Current	4mV	400uA	0.2uV	± (1.5% + 5dgts) (40Hz ~ 500Hz) 40Hz ~ 500Hz
		4mA	2uV	
	400mV	40mA	20uV	± (1.8% + 5dgts) (40Hz ~ 500Hz) 40Hz ~ 500Hz
		400mA	200uV	
	10A	10A	2mV	± (3.0% + 4dgts) 40Hz ~ 500Hz
Resistance	400 Ω		0.1 Ω	± (1.0% + 4dgts)
	4k Ω		1 Ω	± (1.0% + 2dgts)
	40k Ω		10 Ω	
	400k Ω		100 Ω	
	4M Ω		1k Ω	± (2.0% + 4dgts)
	40M Ω		10k Ω	± (3.0% + 5dgts)
Continuity	Beeper is activated when the resistance is below 80 Ω			
Rated Fuse	250 Volt 800 mA			

## 4. FUNCTIONAL USE

### ● Power ON/OFF

The power switch is located on the side of the handset.

Turn the power switch on, and press  to start SecuriTEST.

To turn off the system, press & hold  for more than 3 sec. Then, POWER OFF is displayed on the main screen with a beep. Release the button. Turn the power switch OFF to prevent battery drain during storage. The switch must remain ON to recharge the batteries.

A rechargeable battery should be plugged in over 8 hrs to fully charge. The charged battery can operate for about 3 hours.

When the battery indicator shows below , recharge it for use. (Full charge: )

### ● OSD Setup Screen When Power is ON

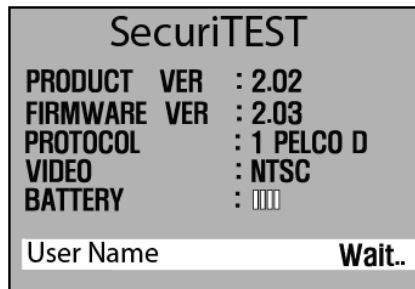

When power is turned on, the OSD is displayed, and it automatically changes to the video test mode after 3-5 seconds.

The initial OSD displays the SecuriTEST version and the initial setup on the screen.

Product Version: 2.02  
Firmware Version: 2.03  
Initial Protocol: PELCO-D  
TV Mode: NTSC / PAL (automatic setup)

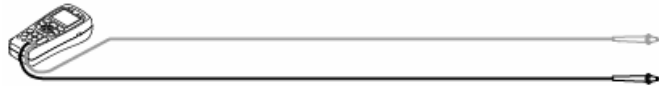

Battery Indicator:   
User Name: User's name (Name can be changed in the Main menu)

*Model & Software versions are subject to change without notice.*

## ● Mode Setup

Pressing the **MODE** key changes the operation mode between VIDEO, DMM, PTZ, and UTP.

To directly select a mode, press and hold the **SET** key for 3 seconds then choose a mode and press the **MODE** key again to select the mode.

MODE SELECT	
VIDEO TESTER	
DIGITAL MULTIMETER	
PTZ CONTROLLER	VIEW INFORMATION
UTP CABLE TESTER	MAIN SETTING

### Video Tester Mode:

In this mode, the image quality of the external input picture signal is tested. Unlike most monitors, SecuriTEST does not have a video input amplifier, thus picture quality problems caused by long cable runs or poor connectors will be seen. The same signal input into a standard external monitor may look fine since the monitor will boost the signal to make the image look clear. The un-amplified input circuit allows users to troubleshoot cable and connector problems that would normally go unnoticed. The VIDEO mode also outputs color test patterns to aide in troubleshooting or setting up monitors.

**Digital MultiMeter Mode:**

Use the MultiMeter mode to measure voltage, current and resistance. In the resistance mode the continuity beeper can be turned on to generate an audible tone when the measured resistance is less than 80 ohms.

**PTZ Controller Mode:**

In this mode, the up, down, right, left movement for PTZ cameras is controlled. Zoom and focus can also be adjusted using the Tele/Wide and Far/Near buttons.

**UTP Cable Test Mode:**

UTP cables are tested for straight (direct), crossover, opens, and shorts. The yellow UTP terminator must be placed on the far end of the cable to make measurements. Press the SET button to begin the cable test.

The UTP test does not report the length of the cable.

**View Information Mode:**

In this mode, the basic information of SecuriTEST can be seen (firmware version, battery level, communications protocol and speed).

**Main Setting Mode:**

In this mode, the basic setup of SecuriTEST can be changed (user's name, auto power off time, beeper, brightness, contrast, etc).

**HELP:**

HELP information relevant to the current mode is displayed when the key is pressed on for more than 2 seconds.

This function gives a brief explanation of the current function.

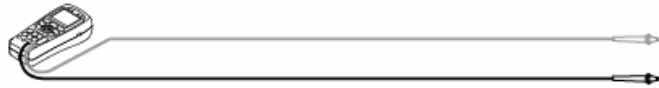

## ● VIDEO TEST



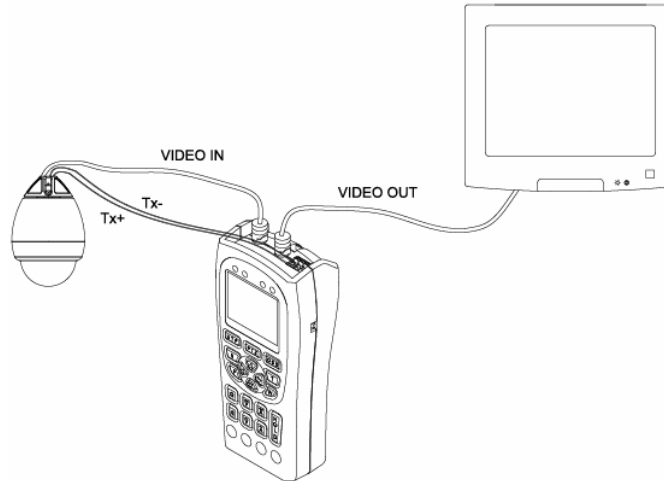



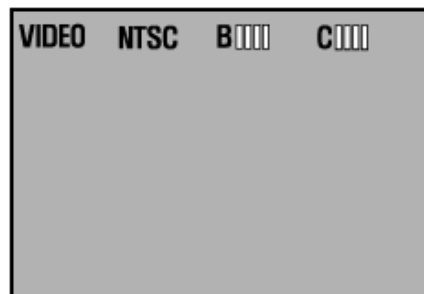

Connect the output of video output system to the video input BNC of SecuriTEST.  
Connect the video output BNC of SecuriTEST to the video input terminal of the CCTV system. The image that is displayed on SecuriTEST is passed through to the external monitor.



### OSD Screen Setup



VIDEO: Indicates that the system is in the video test mode.

- NTSC: Indicates if input or output video signal system is NTSC or PAL. Input video signal is displayed on LCD screen automatically. Output video signal in Pattern Generator mode can be switched to NTSC or PAL, using the  or  keys.
- B : Indicates screen brightness. The brightness of the SecuriTEST LCD increases gradually by +1 when  key is pressed, and decreases gradually by -1 when the  key is pressed. Returns to the initial setup value when one of the two keys is pressed for more than 3 sec. Changes to brightness do not effect the image sent through SecuriTEST's Video OUT port.
- C : Indicates screen contrast, and the contrast increases gradually by +1 when  key is pressed, and decreases gradually by -1 when  key is pressed. Returns to the initial setup value when one of the two keys is pressed for more than 3 sec. Changes to contrast do not effect the image sent through SecuriTEST's Video OUT port.

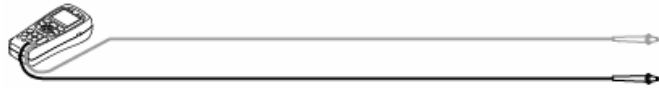

### Pattern Generation Mode

To enter the PATTERN GENERATION MODE press the





key while in the VIDEO mode.



Output is changed between NTSC or

PAL, using  or  keys.

Output patterns can be cycled between  
COLOR BAR, RED, BLUE, GREEN

using  or  keys.



COLOR  
BAR

RED

BLUE

GREEN

Press  key to return to Video MODE.

## • Digital Multi-Meter



Voltage, Current, Resistance, continuity can be measured.



### WARNING

To prevent an electric shock, injury or damage to SecuriTEST, turn off the power supply of the circuit and discharge all the high-voltage capacitors before testing resistance and continuity.

When using the meter function of your SecuriTEST, make sure to turn on its power and set the proper mode before connecting the test leads to the circuit to be tested.

### Key Selections

Press the  button, and then press  button to change to continuity mode (continuity beeper on).

Press the  button, and then press  button to cycle between ACV/DCV.



This button is used to test Current below 4mA.



This button is used to test Current below 400mA.



This button is used to test Current below 10A. This input is not fused. Be careful not to measure across a live circuit (as when making a voltage measurement) when the probe is connected to the 10A input. Doing so will create a short circuit and damage the meter.



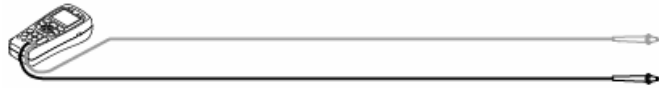

### Description of Meter Mode LCD Window

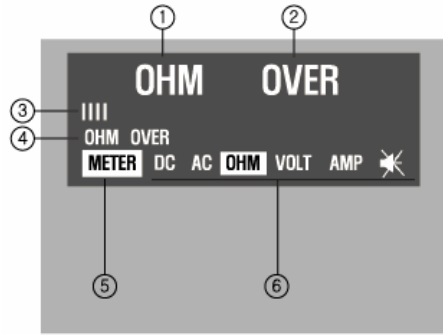



PART	FUNCTION	DESCRIPTION
①	Test Mode	<ul style="list-style-type: none"> <li>- Resistance test</li> <li>- Continuity test</li> <li>- Set-up tests of DC/AC voltage, current</li> </ul>
②	Test Value	<ul style="list-style-type: none"> <li>- <math>\Omega</math> unit of resistance test is indicated</li> <li>- Indicator of AC or DC value of voltage or current</li> <li>- AC voltage &amp; current are indicated as RMS (root mean square)</li> </ul>
③	Measured Value Graph	<ul style="list-style-type: none"> <li>- Input measured value is indicated in the form of a bar graph relative to the maximum input level of the selected mode</li> <li>-</li> </ul>
④	Measured Value in Memory Hold	The measured value is stored and indicated here when SET key is pressed while taking measurements
⑤	MODE Display	Digital MultiMeter Mode is displayed

PART	FUNCTION	DESCRIPTION
⑥	DC	DC Voltage test
	AC	AC Voltage test
	OHM	Resistance test (Measuring unit: $\Omega$ )
	VOLT	Voltage test (Measuring unit: V)
	AMP	Current test (Measuring unit: mA, A)
		Continuity test (Beeps below 80 $\Omega$ )

### Measuring Resistance

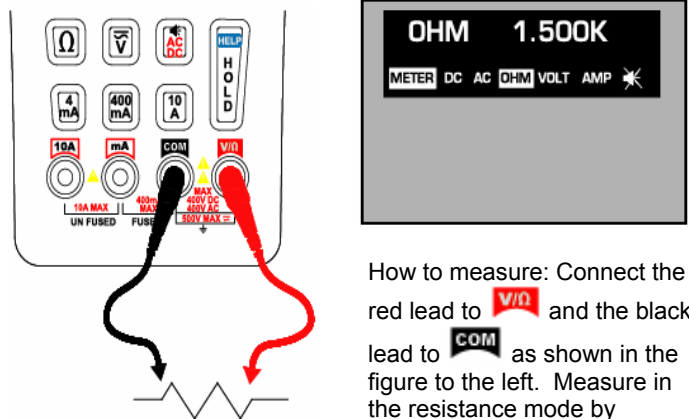
The unit of measurement is  $\Omega$ . The meter sends low current into the circuit to measure its resistance.



How to measure: Connect the red lead to **V/Ω** and the black lead to **COM** as shown in the figure to the left. Measure in the resistance mode by pressing  on the keypad.

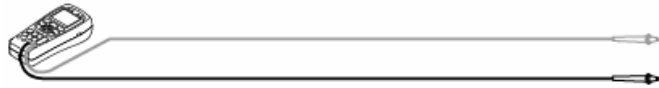

## Testing Continuity

Continuity indicates the presence of a complete path for current flow. The continuity test features a beeper that sounds when a circuit is complete. The beep allows users to quickly test continuity without having to watch the display.

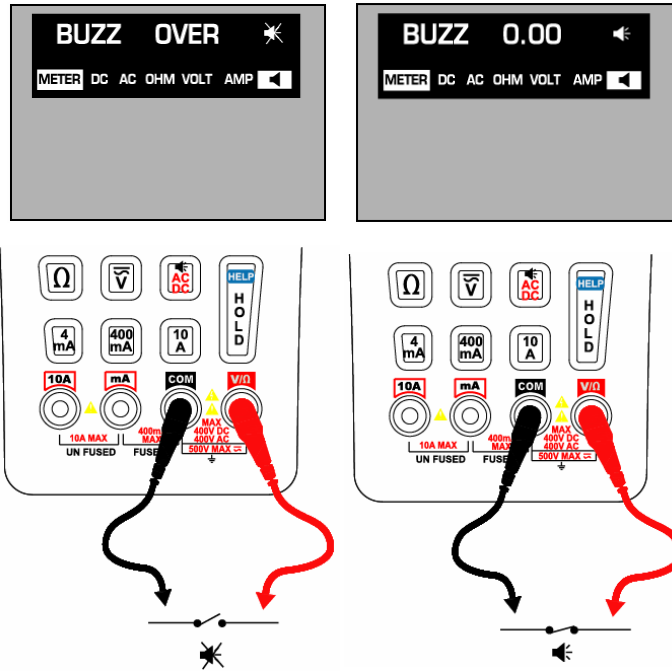



How to test: The resistance mode changes to the

continuity mode, when  is pressed. The beeper is activated when the resistance between the red probe and black probe is below 80Ω.

## Measuring AC & DC Voltage

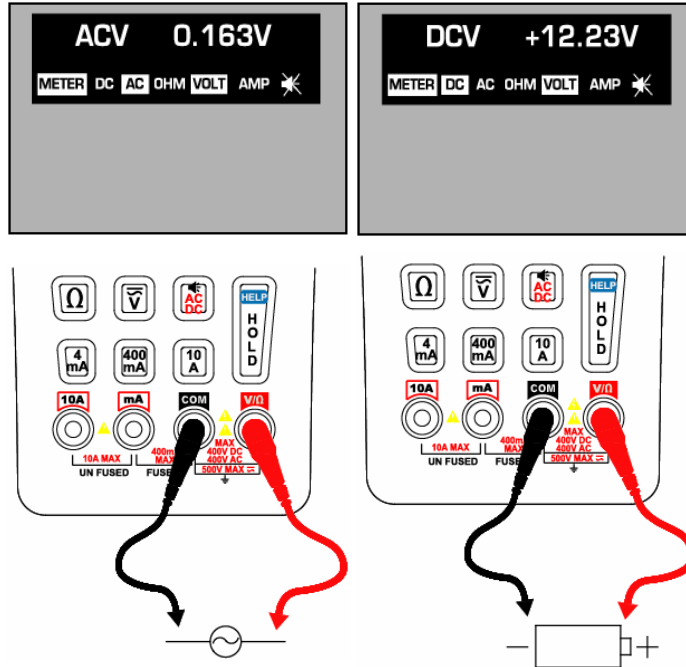
Voltage means the difference in electrical potential between two points. The polarity of AC voltage varies over time, while the polarity of DC is constant over time. The meter displays AC voltage value as RMS (root mean square) readings. The RMS value means the equivalent dc voltage that can produce the same amount of heat in a resistance as the measured sinewave voltage.



How to measure: First, press  , the voltage measuring button, then selects AC or DC by

pressing  . When measuring DC, place the red lead on the “+” point, and the black lead on “-” point of the circuit.

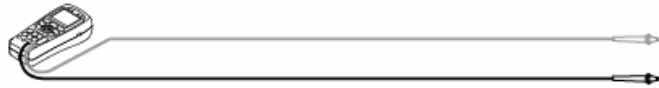

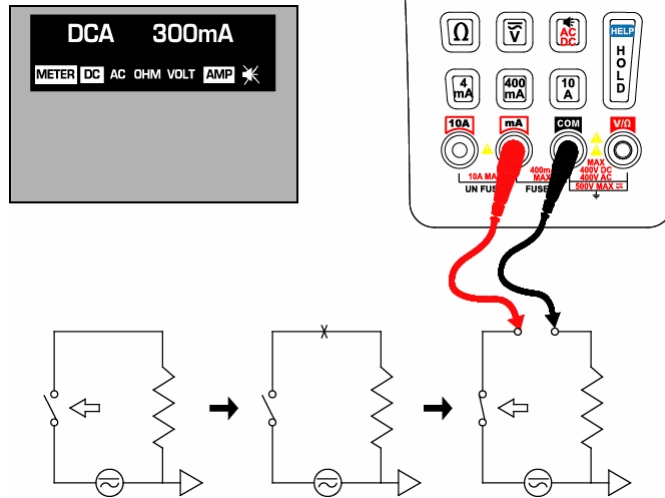

## Measuring AC & DC Current

Current is simply defined as a flow of electrons running through a conductor. To measure current, you must break the circuit under test, and place the meter in series with the circuit. The current measuring range of the meter is 10A max.



How to measure: First, turn off the power to the circuit and discharge any high voltage capacitors. Place the red lead into the mA or 10A terminals in accordance with the

value to be measured. Select one of the buttons ,

 or .

When  &  are selected, place the red lead on

mA. When  button is selected, place the red lead on 10A.

 **WARNING**

Check the position of the test lead set in current test mode. Place the red lead at mA only when below 400mA, and place it at 10A when the value to be tested is over 400mA, or the value is unknown.

 **WARNING**

Do not attempt to measure voltage when the test leads are connected to the mA or 10A port. Doing so will create a short circuit condition and blow the internal fuse or cause damage to the instrument and possibly cause bodily injury.

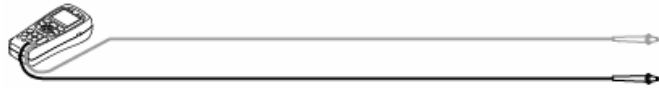

## ● PTZ Controller

Connecting Camera and Monitor

PTZ Operation Test: Up, Down, Left, Right, Zoom and Manual focus control are possible. The tester can also be set to various protocols and transmission speeds (baud rates).

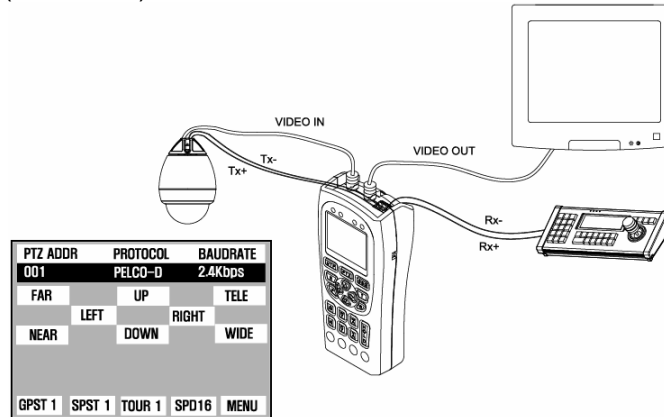

- PTZ Control Setup Screen

Press and hold the SET button for 3 seconds until PTZ protocol menu activates.

PTZ ADDR	PROTOCOL	BAUDRATE
001	PELCO-D	2.4Kbps
GPST 1	SPST 1	TOUR 1
		SPD16
		MENU

Address Setup Screen

PTZ ADDR	PROTOCOL	BAUDRATE
001	PELCO-D	2.4Kbps
	PELCO-P	
	WDMW00	
	SPD-2500	
	SCC-643	
	SJ-100	
	SJ-1000	
GPST 1	SPST 1	TOUR 1
		SPD16
		MENU

Protocol Setup Screen

PTZ ADDR	PROTOCOL	BAUDRATE
001	PELCO-D	2.4Kbps
		4.8Kbps
		9.6Kbps
		19.2Kbps
		38.4Kbps
GPST 1	SPST 1	TOUR 1
		SPD16
		MENU

Communications Speed Setup Screen

## - Keyboard Control Code Screen

PTZ ADDR	PROTOCOL	BAUDRATE
001	PELCO-D	2.4Kbps
FAR	UP	TELE
LEFT	RIGHT	
NEAR	DOWN	WIDE
FF 01 08 04 3F 3F 8B		
FF 01 08 04 3F 3F 8B		
FF 01 08 04 3F 3F 8B		
FF 01 08 00 00 00 09		
GPST 1	SPST 1	TOUR 1
	SPD16	MENU



- The control commands from the keyboard of an external control are displayed on the screen. Most important is that the communications speed be matched.

When you want to know the input signal of an exterior controller, you can see the input data by connecting the communications cable to the RX terminal of the SecuriTEST.

### Using the PTZ Controls

PT control (Up, Down, Left, Right), is performed using the arrow keys. Zoom is controlled using the TELE/WIDE buttons, and focus is controlled with the FAR/NEAR buttons.

### PTZ Function Setup





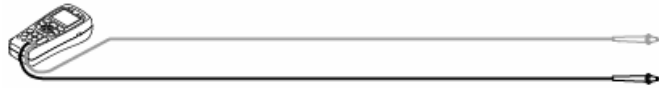

Press the  key then use the arrow keys to select GPST / SPST / TOUR / and SPD functions. Press  to activate a function

GPST: Short for GO TO PRESET - Moves the camera view to the designated preset location. SecuriTEST can address up to 99 stored positions in the camera. The camera goes to the GPST position after the  key is pressed. Select the previously memorized PRESET number using the arrow keys. When the desired number is displayed, press





 to move the camera to the stored position.

SPST: Short for SET PRESET - Memorizes PRESET. Setup can range from 1 up to 99. First, move the camera to the desired position. Press the  key to activate the menu, then using the  &  keys, select SPST and set the address to store using the  &  keys. Press the  key once more to save the address. This function saves the current camera position into the cameras internal memory. This set position can be recalled from SecuriTEST or any other PTZ controller at a later time.

TOUR: Operates TOUR through SPST points. Can be programmed from 1 to 99. TOUR is set using the same process described for the SPST function. To program the camera tour, the camera must support programming via the SecuriTEST interface. This is accessed by using the MENU function on the SecuriTEST PTZ screen. If the camera already has tours programmed, use the TOUR mode to recall and activate a tour that was previously saved in the camera.

SPD: Sets the speed of the camera. Programmed using the same described for SPST. Range is from 1 to 16. Always defaults to 15 when cycling power or changing modes. High speeds are preferred to test the cameras operation while low speeds are used for precise control when storing set points (SPST).

MENU: Activates the PTZ camera's internal menu. Many PTZ cameras have an on-screen menu system that allows SecuriTEST to program various functions of the camera including day/night mode, focus settings, and tours. When a tour is programmed into the camera it can be activated with SecuriTEST using the TOUR function in the menu.

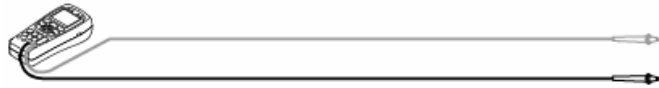



 **CAUTION**

Make sure to check communications protocol, transmission speed, and ID.

**PTZ Control Setup**

PTZ ADDR is activated on the upper part of the LCD screen, when  key is held for more than 3 seconds. The menu also controls the PTZ Protocol and Baud rate.

Use the  &  keys to move between the menus.

**PTZ ADDR:** Select the address of the PTZ Camera. Each PTZ camera in a system must have a unique address from 1 to 255 to allow it to be operated by a PTZ controller. Use the PTZ ADDR function to set the address of the camera to control.

PTZ ADDR	PROTOCOL	BAUDRATE
001	PELCO-D	2.4Kbps

**PROTOCOL:** Choose PTZ PROTOCOL

Camera manufacturer use various communications protocols to control the PTZ functions of the camera. Use the PROTOCOL menu to set the output of SecuriTEST to match the protocol of the camera system in use.

PTZ ADDR	PROTOCOL	BAUDRATE
001	PELCO-D PELCO-P WONWOO	2.4Kbps

\* **BAUDRATE:** Select TRANSMISSION SPEED

The initial setup is 2.4kbps, it can be set from 2.4kbps to 38.4kbps.

PTZ ADDR	PROTOCOL	BAUDRATE
001	PELCO-D	2.4Kbps 4.8Kbps 9.6Kbps 19.2Kbps 38.4Kbps

To escape from the PTZ CONTROL SETUP mode, press the  key again.

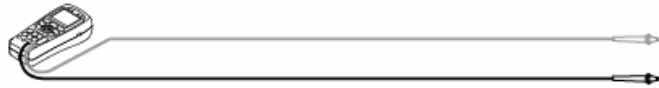

**⚠ CAUTION**

Make sure to check CAMERA ID, PROTOCOL, BAUDRATE when testing. PTZ operation can not be done when the setup is different from the camera. If you are unsure of the cameras configuration, connect the camera to the Video IN of SecuriTEST then cycle the cameras power. Often the camera will display its PTZ configuration during the boot process allowing the tester to be set to a matching configuration.

⦿ **UTP Cable Tester**

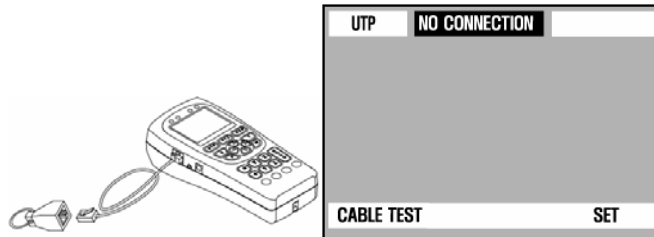

Connect one end of the UTP cable to be tested to the UTP Cable Test port of SecuriTEST and the other end to the yellow UTP Cable terminator.

The condition of the cable can be tested by pressing **SET**. The test can detect straight and crossover cables as well as shorts, opens and most miswire conditions.

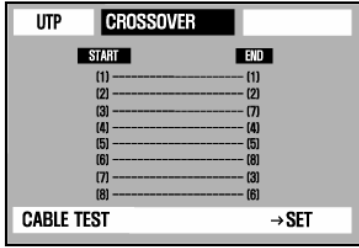

Crossover Cable

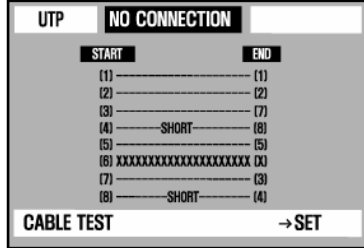

Short-circuit & Disconnection

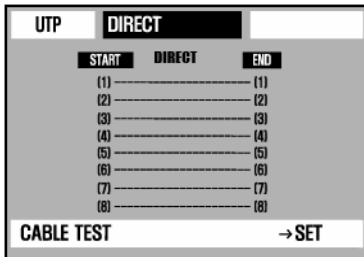

Direct Cable

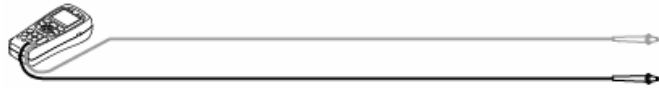

## • View Information



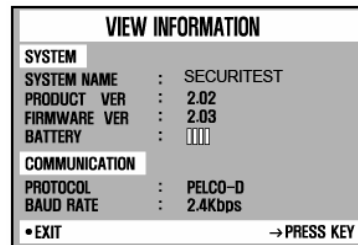
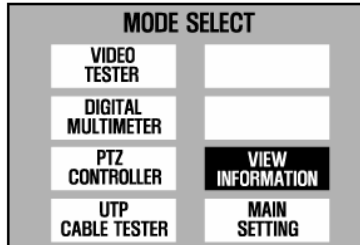

**Mode Setup:** First, press the **MODE** key more than 3 sec. and select VIEW INFORMATION. Press the **SET** key to view the information.

## • Main Setting

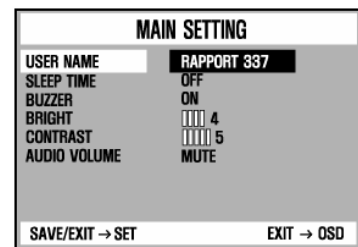
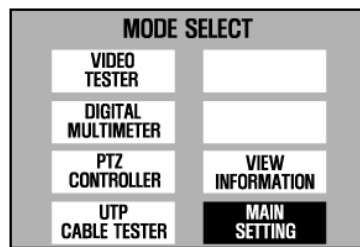

**Mode Setup:** First, press **MODE** key more than 3 sec. and select MAIN SETTING. Press the **SET** key.



Select the item by pressing the  &  keys. Each setup value can be changed by pressing the  &  keys. A user can enter the name he or she wants by editing USER NAME. SLEEP TIME sets the time that SecuriTEST will remain on when no button presses are detected.

IDEAL Industries, INC.  
Becker Place  
Sycamore, IL 60178  
Customer Service: 800-435-0705

[www.idealindustries.com](http://www.idealindustries.com)  
[www.idealindustries.co.uk](http://www.idealindustries.co.uk)  
[www.idealindustries.de](http://www.idealindustries.de)

Printed in Korea  
Rev 2.0 May 2007