

# C+C Miniature LED Digital Panel Meters CX102

CX102 series of digital panel meters proved to of high reliability, good quality and fine workmanship with competitive pricing for a variety of applications. Combining unmatched performance with a high degree of reliability, the 3-1/2 digit LED panel meter is the first choice for many applications that require instrumentation.



CX102 series consist of 2 versions:

- 1) CX102A: 9V independent power supply.
- 2) CX102B: 5V power supply, power supply and signal under measurement can have common ground

## Specifications:

Display	CX102A	CX102B
Type of display	LED, red super bright	LED, red super bright
Digits	3-1/2digits (1999)14.2mm figure height	3-1/2digits (1999)14.2mm figure height
Polarity	Automatic. (-) for negative value	Automatic. (-) for negative value
Power	<b>9V powered, independent</b>	<b>5V powered, common ground</b>
Decimal Point	User selectable	User selectable
Over Range	blinking all digits	blinking all digits
Input(Analog)		
Full scale range	200mV	200mV
Configuration	True differential input & reference	True differential input & reference
Bias Current	10pA maximum	10pA maximum
Impedance	10MΩ	10MΩ
Operation		
Accuracy	±(0.1%rdg.+2 dgt.)	±(0.1%rdg.+2 dgt.)
Conversion rate	2.5 per second	2.5 per second
Com ModeVoltage	±1V maximum	±1V maximum
Com Mode Reject	>86 decibels	>86 decibel
Zeroing	Automatic	Automatic
Tempco	Standard +100ppm/°C	Standard +100ppm/°C
Operating Temp	Standard 0 to 50°C	Standard 0 to 50°C
Storage Temp	Standard -20 to 70°C	Standard -20 to 70°C
Mounting	Window Plug-in with clip	Window Plug-in with clip
Connection Pins	10 pins	10 pins

- Pin 1 - V+
- Pin 2 - V-
- Pin 3 - DP COM, Analog Common
- Pin 4 - DP1, Decimal point left of hundreds digit
- Pin 5 - DP2, Decimal point left of tens digit
- Pin 6 - DP3, Decimal point left of units digit

- Pin 7 - INPUT (+)
- Pin 8 - INPUT (-) Pin 10 - No Connection
- Pin 9 - No Connection
- Pin 10 - No Connection

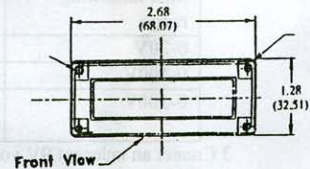
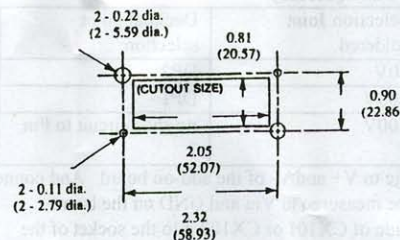
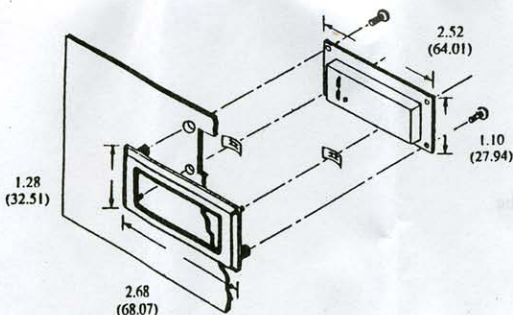

### Full Scale Adjustment

This is done and Q.Ced in our factory. However, after adding voltage divider, further adjustment sometimes is needed to the trimpot on the back of this DPM.

### Input/Output Connections (for CX102B only)

In systems where the power supply and signal under measurement are isolated, pins 2 and 8 should be connected directly or through a 10KΩ resistor.

### Decimal Point Selection

The decimal point is user selectable for three positions by simple pinstrapping. The decimal point is selected as follows:

- Pin 4 shortcircuits to Pin 3 - lights the decimal point left to hundreds digit
- Pin 5 shortcircuits to Pin 3 - lights the decimal point left to tens digit
- Pin 6 shortcircuits to Pin 3 - lights the decimal point left to units digit

### Caution

**For CX102A, the supply voltage should be between 7.2-11V DC**

**For CX102B, the supply voltage should be between 4.75-5.25V DC.**

**If outside the operating voltage, it will damage the units permanently.**

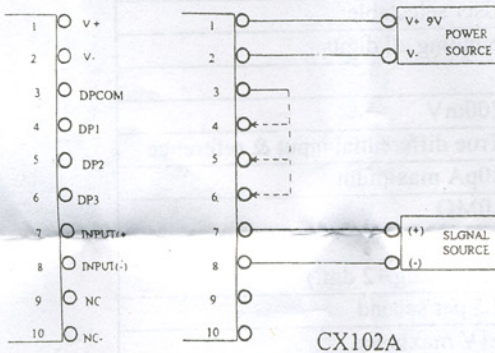

Wiring Diagram for CX102A (9V independent P/S)

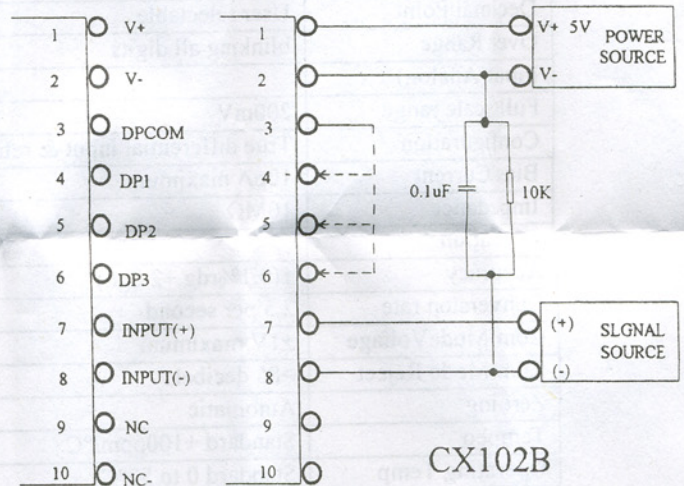

Wiring Diagram for CX102B (5V common ground P/S)

### How to use the add-on board:

We have also developed an easy-to-use add-on board, to have all the precision voltage divider resistor added thereon.

- 1) The add-on board is used to expand the measuring range from  $\pm 200\text{mV DC}$  to  $\pm 20\text{V}$ ,  $\pm 200\text{V}$ ,  $\pm 500\text{V DC}$ .
- 2) **Make the measuring range selection** by soldering the selection joints 20V, 200V or 500V and also select the decimal point therefor by shortcircuiting the points marked DP1, DP2 or DP3 to Pin 1 (CX101) or to Pin 3 (CX102).

Max measuring range	Selection Joint soldered	Decimal point selection
0-20V	20V	DP2
0-200V	200V	DP1
0-500V	500V	no shortcircuit to Pin 3

3. Connect an independent 9V voltage to V+ and V- of the add-on board. And connect the both ends of the voltage to be measured to Vin and GND on the board.
4. Insert the pins on the back side of CX101 or CX102 into the socket of the add-on board, pin by pin, 13 pin socket for CX101 or 10 pin socket for CX102. especially pay attention to polarity.
5. The miniature digital panel meter and the add-on board are ready to use.