

Test-Um Inc.

The Intelligent Test Solutions Company

Part No. **WP150**

Wi-Net Window™

Wireless Scanner & Pinger
Operating Instructions



Product Features

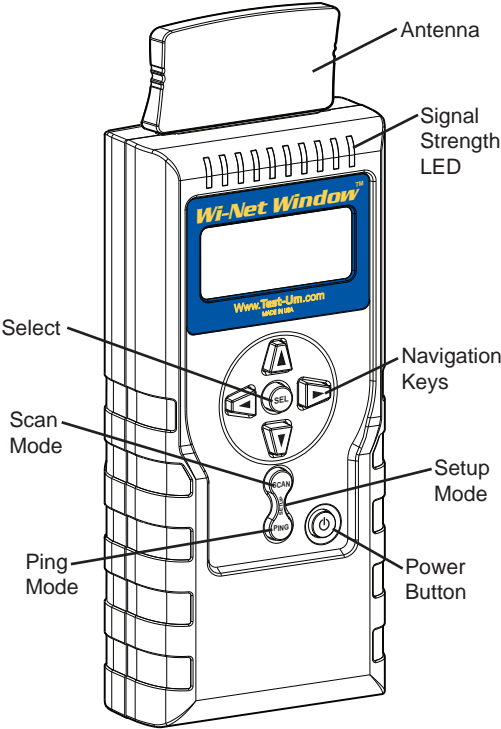

LCD Indicators

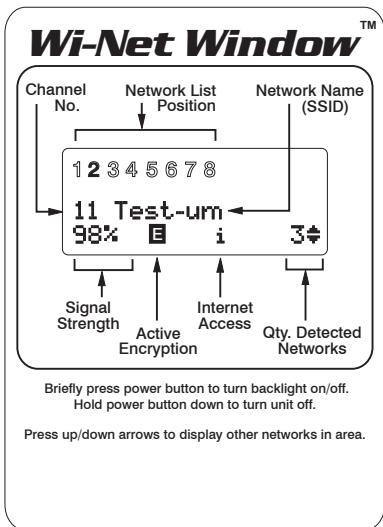

Table of Contents

Product Features	1
Battery Installation	2
Instructions For Use	3
Scan Testing Mode	4
Ping Testing Mode	8
Pinging Unsuccessful	10
Main Setup Menus	13
Ping Setup	15
DHCP Mode On/Off	15
Last DHCP	16
Target Setup	18
Audio Setup	19
Advanced Mode Option	20
Shutdown Timeouts	21
My MAC Address	21
Status and Error Messages	22
Internet Protocol Definitions	28
Specifications	33
Maintenance	34
Warranty	35
Returning Equipment	36

Product Features

Wi-Net Window™ is a wireless network analyzer that detects and connects to wireless equipment, reports signal strength, pings IP addresses, and identifies network components.

- Displays signal strength on LED and as a percentage on the LCD
- Scans and logs all wireless transmissions in the area
- Identifies the name and transmission channel of the equipment detected
- Works with IEEE802.11 b and g wireless devices
- Displays Internet access capability and encryption status on each wireless component
- Identifies the signals as either an access point (infrastructure) or ad-hoc
- Pings IP addresses and checks for a viable link to the Internet
- Negotiates with network DHCP to identify components and IP/MAC addresses
- Operates on 4 AA batteries

Battery Installation

Batteries are not included. A low battery condition may result in unreliable operation. A low battery icon indicates the battery should be replaced as soon as possible. Replace the battery as shown below.

1. Using a #1 Phillips screwdriver, unscrew and remove the battery cover on the back of the unit.
2. Connect 4 AA size Alkaline batteries to the battery snaps.
3. Slide the batteries into the cavity.
4. Close the battery cover and replace the screw. Do not overtighten.

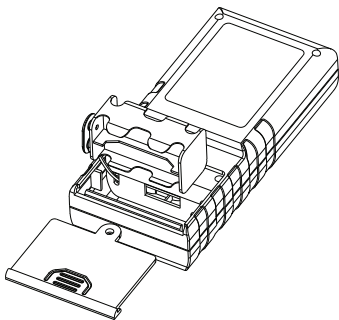

Instructions For Use

To turn on the Wi-Net Window press the Power, SCAN or SETUP key. To turn the unit off, hold the Power key down until the display turns off. Briefly press the Power key to toggle the backlight on/off. The tester will automatically turn off after 10 minutes of no activity (i.e. no key press). See **Shutdown Timeouts** in the Main Setup Menus section of this manual for more timeout options.

The Wi-Net Window includes two test modes, Scan and Ping, which are designed to detect and connect to wireless network equipment and verify Internet access capability. Press their respective keys to enter these test modes.

All manually entered parameters, and administrative options (e.g. audio, advanced mode, etc.), are saved when the Wi-Net Window is turned off. To reset these to their factory-defaults, press the up arrow key while powering the unit on.

Scan Testing Mode

Scan Testing identifies wireless network devices and displays the network name (SSID) associated with the device. The signal strength of the wireless LAN (WLAN) detected displays on the LCD in percentage format and also on the LED bar graph at the top of the unit.

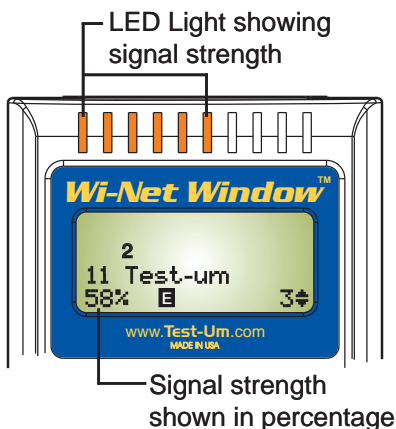

WLANs detected during scan are ordered by channel number and network name (SSID). Use the arrow keys to scroll up and down the list of detected WLANs. The WLANs relative position within the list is depicted by illuminating one of the fixed numbers (1-8) in the numeric sequence above the SSID.

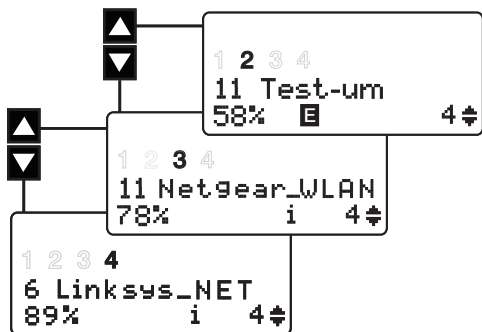

During scanning a ping is sent to the Internet IP every 15 seconds. If a response is received, an Internet indicator (i) is displayed.

If an Access Point (AP) is detected that encrypts its data, the letter “E” displays on the LCD during scanning. If the data is encrypted, Ping testing is not operational.



If two WLANs are using the same SSID and channel, a twin status (**t** or **twin**) is displayed (they are differentiated by their MAC addresses). This can indicate a problematic network configuration or an attempt to initiate an “evil twin” scam.

Additional network status is available when operating in the Advanced Mode. See **Advanced Mode Option** in the Main Setup Menus section of this manual for a complete list of status indicators.

Multiple presses of the SEL button display the unique IP address assigned to your Wi-Net Window, the Router's IP address, and the Access Point MAC address.

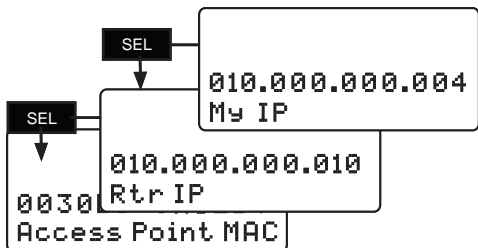

Each of these displays are shown for up to 10 seconds. Press SEL to move past them more quickly.

When operating with DHCP off, editing is allowed on the My IP and Rtr IP displays. Once editing starts, the display remains active until accepted via the SEL key, or canceled via the SCAN, PING or SETUP keys.

If the router and access point are the same, it is indicated by the caption “AP & Router IP.”

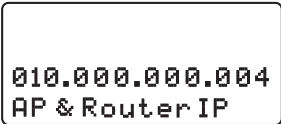

010.000.000.004
AP & Router IP

Press SEL to display the corresponding MAC address. Since most wireless networking hardware has a visible MAC address label, this allows the components of the wireless network to be identified more easily.

A scan for all hosts (AP's) is initiated every 6 seconds. If a WLAN is not detected after 4 scans (24 seconds), its signal strength is set to 0%. If there is no activity after an additional 70 seconds, the WLAN is removed from the scan. It may be removed earlier if a more active WLAN displaces it.

The currently displayed WLAN is locked and will not be removed unless you scroll to a different WLAN or the unit is turned off. The Wi-Net Window tracks and identifies up to 8 WLANs simultaneously based on signal strength.

Ping Testing Mode

The Ping test is used to verify connectivity to resources on or off the network and IP addresses. The Ping test can be run in DHCP or manual addressing mode.

During Ping testing, the channel number, SSID, ping target and count values for the transmitted and received ping packets display on the LCD. The WLAN signal strength displays on the LCD in percentage format and also on the light bar at the top of the unit.

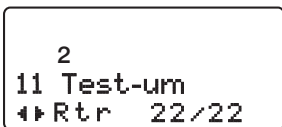

Use the left and right arrow keys to view the ping test results for the IP addresses associated with the WLAN selected, including the Router, DNS, target IP addresses 1-4, and the Internet.

As you scroll through the respective targets during ping testing, press SEL to identify the Wi-Net Window's IP address, the IP address of the wireless network device pinged, the length of time it took for the last ping, as well as the average ping response time in milliseconds.

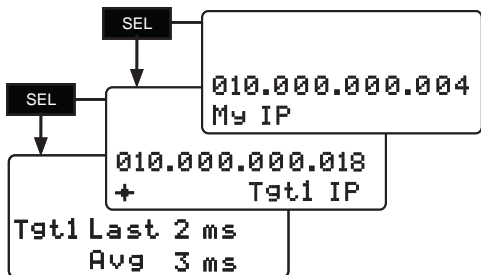

The Ping Target IPs can be viewed and edited from this display. The Internet IP can only be edited from the Target Setup submenu during Setup mode.

Pinging Unsuccessful

When a ping target is selected, the Wi-Net Window tests the currently defined network parameters and displays one of the following messages if it is unable to send a ping.

```
TEST  
10 Netgear_WLAN  
➡Tgt1    no/rsp
```

```
TEST  
10 Netgear_WLAN  
➡Tgt2    no/rtr
```

```
TEST  
10 Netgear_WLAN  
➡Tgt3    in/use
```

The problems that can prevent a ping from being successful include a non-existent target (i.e. no ARP response), an invalid Router IP (when the target is not on the local network), or when the unit's IP address (My IP) is already in use on the network.

When starting Ping testing, the following messages may be displayed if a problem or delay is encountered

Message	Description
No WLAN detected continue to SCAN	No WLAN has been detected via SCAN so there is nothing to ping.
DHCP Off Err IP = 0.0.0.0	DHCP is not active and a Manual IP has not been entered.
Ad-hoc network no DHCP offered	Ad-hoc WLANs do not support DHCP.
Waiting on DHCP for my IP X	Waiting for a DHCP assignment; the number (X) is incremented for each DHCP request (~every 10 sec).
DHCP On/Off Verifying Addr	The Manual, or DHCP assigned, IP is being checked via ARP to verify that it is not already in use.
My IP is in use on this network	Some other system is already operating on the network with the Wi-Net Window's assigned or Manual IP.
No DHCP located to assign My IP	There was no response to multiple DHCP requests on the network.

If no DHCP response is received, a ping is attempted every 10 seconds for 2 minutes, then it stops.

To restart the DHCP request cycle, press the Scan or Ping key. While scanning, you can also scroll off and back on the WLAN. If a DHCP assigned IP is already in use, the Ping test is retried after a one minute delay.

Whenever possible, IP address screens are augmented with additional error status messages. For a complete list of Error and Status messages, see the **Status and Error Messages** section in this manual.

For example, if a specified Router address does not respond to ARP requests an error message “Rtr: No resp.” displays. Also, if a Target IP is not on the local network, and the router is unresponsive “Tgtx: No Rtr” displays.

Main Setup Menus

Press the center of the Scan/Ping button to enter SETUP mode. The first four setup menus contain options related to the Ping Test function.

The last four setup menus contain administrative options, such as display preferences, audio tones, shutdown timeouts, and the MAC address assigned to your Wi-Net Window.

Use the up and down arrow keys to scroll through the list of Setup Menu options. Press SEL to view or edit the information on each submenu.

When you initially press SETUP, the percentage of remaining charge on the battery displays briefly. A Low Battery icon indicates the battery should be replaced as soon as possible. See the **Battery Installation** section of this manual.

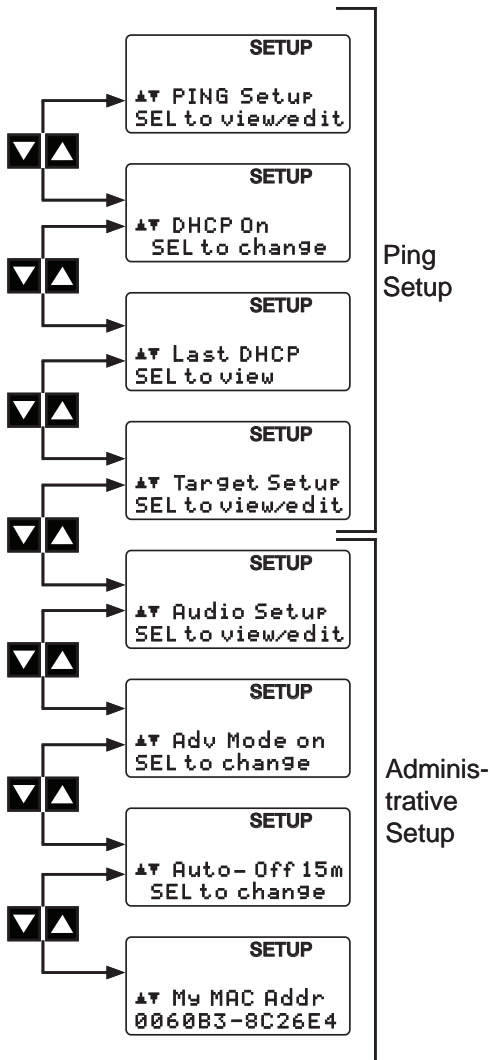

Ping Setup

Ping targets can be selected and edited during Ping Testing. Press and hold SETUP to display the Ping Setup menu. Press SEL to view/edit the **Manual IP** or press the down arrow to advance to the **Router IP** or **Netmask** submenus. When DHCP is off, this manually entered IP information is used for Ping testing.

To change the Manual IP, Router IP, or Network Mask, press SEL and use the right arrow key to position the cursor beneath the digit you wish to change. Press the arrow key again to increment the value of the respective digit in the IP address up or down.

Press SEL to save changes and navigate to the next Ping Setup submenu. Press the Setup key to cancel editing without saving changes. At the bottom of the Ping Setup submenu, press SEL to return to the Main Setup Menu.

DHCP Mode On/Off

The Ping test operates in either DHCP mode On (default) or Manual DHCP mode (Off). Press the down arrow key to select the DHCP Mode On/Off

submenu, then press SEL to toggle DHCP off or on. Press the down arrow to navigate to the next submenu.

Last DHCP

The Last DHCP submenu identifies the DHCP Host information associated with the currently selected WLAN. Press SEL to view the IP information associated with the current DHCP Host, Router, DNS Server and Network Mask.

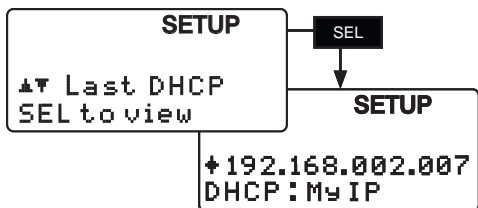

Use the up and down arrow keys to scroll through the Last DHCP items. Press SEL to view an item's MAC address. Since most wireless networking hardware has a visible MAC address label, this allows the components of the wireless network to be identified more easily.

When a DHCP Host and its identified router have the same IP, they are shown on one screen.

SETUP

†192.168.002.024
DHCP Host=RtrIP

If no information regarding the last DHCP is available a message confirming this displays briefly. Press the down arrow to move to the next submenu, view/edit Ping targets.

SETUP

No DHCP host
was found

Target Setup

Ping testing includes four custom IP targets (Tgt1-Tgt4), and an Internet IP. From the Target Setup submenu, press SEL to view and edit the target IP addresses. Target IPs can also be viewed and edited while Ping testing is active.

Use the down arrow key to scroll through the Target submenus. Press SEL to view or edit the corresponding target IP. Use the right arrow key to position the cursor beneath the digit you wish to change. Press the up or down arrow key again to increment the value of the respective digit in the IP address up or down. Once editing is complete, press SEL to navigate to the next target and repeat the same process.

Press SEL to save changes and navigate to the next Target submenu. Press the Setup, Scan or Ping buttons to cancel IP editing without saving changes. At the bottom of the Target submenus, press SEL to return to the Main Setup Menu.

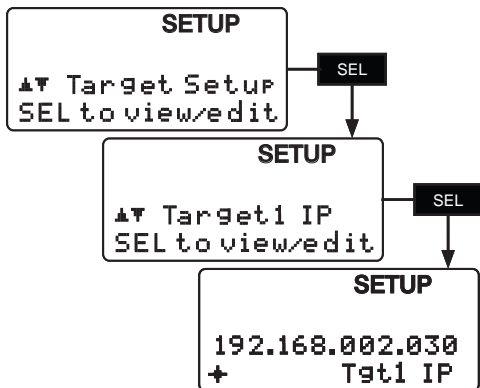

Audio Setup

The Audio Setup menu allows you to toggle audio tones on or off by pressing SEL. By default, all of the audio tones are initially enabled, except for the twin warning.

Message	Description
New WLAN	A single high-low-high tone whenever a new network is detected
Twin Warn	A longer tone every 7 seconds when the displayed WLAN channel and SSID matches another WLAN.
Low Batt	A low-high tone every 30 seconds when the battery icon is visible.
Keypress	A short beep when a key is pressed or when the Power key is released.
Start/End	A single short beep when the unit is powered on. Two short beeps when the unit is powered off.

Advanced Mode Option

The Advanced Mode (Adv Mode) option on the Setup Menu toggles on/off to control the amount of information displayed on the Scan screen. When Advanced Mode is active, the Scan screen identifies additional conditions related to the current WLAN. When the unit is powered on, an Advanced Mode indicator (-Adv Mode-) briefly displays if this option is enabled.

Normal	Advanced	Description
i	intr	Internet access is available
x	InUse	My IP is already in use
	ip	My IP assigned by DHCP
	ap	Connected to access point
	adhoc	Ad-hoc network (peer-to-peer)
t	twin	2 WLANs have the same SSID and channel
	b	802.11b Access Point
	g	802.11g Access Point

Shutdown Timeouts

The Auto-Off menu allows you to select the number of minutes with no key input before the unit automatically powers down. Press SEL to cycle through the set of possible timeouts (5, 10, 15, and 30 minutes). Press and hold the left arrow key and press SEL to disable the automatic shutdown (displays 99m).

When the screen displays the timeout option you prefer, press the down arrow to navigate to the next submenu.

My MAC Address

This screen displays the unique MAC (Media Access Control) identification number associated with your Wi-Net Window test instrument.

Status and Error Messages

**No WLAN detected
continue to SCAN**

When entering PING this message is displayed if no WiFi networks have been detected. Goes to SCAN after a 5 second delay. Press any key, except SETUP, to immediately go to SCAN.

DHCP Off

Err IP = 0.0.0.0

When entering PING this message is displayed if DHCP is not active (off) and a Manual IP has not been entered (defaults to 0.0.0.0). Goes to SETUP after a 5 second delay. Press any key, except SCAN, to immediately go to SETUP.

**Ad-hoc network
no DHCP offered**

When entering PING this message is displayed if the current WiFi network is ad-hoc (IBSS) and DHCP is on. Ad-hoc networks do not support DHCP so the Wi-Net Window cannot be automatically assigned an IP address. Turn off DHCP and

enter a Manual IP in order to ping ad-hoc networks. Goes to SCAN after a 5 second delay. Press any key, except SETUP, to immediately go to SCAN.

**Waiting on DHCP
for my IP x**

When DHCP is on, this message is displayed whenever the Wi-Net Window's IP address is required before proceeding (e.g. when entering PING). The number is incremented for every DHCP request sent (about once every 10 seconds) until an IP is assigned or 12 requests have been sent. After 12 unanswered requests the display goes to: **No DHCP located to assign my IP.**

**No DHCP located
to assign My IP**

This indicates that the current network has not responded to 12 DHCP requests. This could be due to the lack of a DHCP server, or because the WiFi signal is encrypted. Pressing PING or SCAN causes the DHCP request cycle to restart.

**Waiting for DHCP
to find Router IP**

This indicates that the Wi-Net Window is issuing DHCP requests on the current network and must complete this step before the IP address of the router is known.

**No DHCP located
to find Router IP**

This indicates that the current network has not responded to DHCP requests; consequently the Wi-Net Window is unable to determine the IP address of the router.

**DHCP On (Off)
Verifying Addr**

When entering PING this message is displayed while the Wi-Net Window verifies that its IP is valid for use on the current network (i.e. no other system responds to an ARP of that IP).

**My IP is in use
on this network**

This indicates that the IP assigned to the Wi-Net Window conflicts with another system on the network. This most

often occurs when assigning a Manual IP, so return to SETUP and enter a different Manual IP. Otherwise it could result from a faulty DHCP host or indicate that a new system was just added to the network.

My IP is invalid

When entering PING this message is displayed if the Wi-Net Window is unable to establish a proper IP for use on the current network.

**No DHCP host
was found**

This message is displayed when selecting the Last DHCP option from the SETUP menu and the current network is ad-hoc or has not responded to any DHCP requests. The display returns to the SETUP menu after 5 seconds.

**No DHCP info
is available**

This message is displayed when selecting the Last DHCP option from the SETUP menu and DHCP is off, or DHCP requests are still being sent to the current

network. The display returns to the SETUP menu after 5 seconds.

**Wireless card
not detected**

This message is displayed when the Wi-Net Window starts and it is unable to communicate with its wireless hardware. The display goes to the SETUP menu after 5 seconds.

**DNS is unknown
when DHCP is off**

This message is displayed during PING if information on the DNS target is requested by pressing the SEL key. It indicates that a DNS IP is only available when communicating with a DHCP host.

**Manual IP cannot
be 0.0.0.0**

This message is displayed after editing the Wi-Net Window's Manual IP and pressing SEL. An IP address of 0.0.0.0 is not permitted on a network. After 6 seconds the editing display reappears with the original IP value (prior to editing).

**Manual IP cannot
be 224-255.x.x.x**

This message is displayed after editing the Wi-Net Window's Manual IP and pressing SEL. The IP address range of 224.x.x.x to 255.x.x.x is reserved for special use on a network. After 6 seconds the editing display reappears with the original IP value (prior to editing).

**Rtr must be on
MyIP LAN segment**

This message is displayed when editing the Router IP and trying to change its upper address to be different from the Manual IP address. The Router IP must match the Manual IP wherever the Netmask bits are set. This is necessary in order for them to be operating in the same network address space.

Rtr: No ARP resp

This message accompanies the display of a router's IP address. It indicates that ARP requests to the router for its MAC address have not been returned.

Internet Protocol Definitions

AP = Access Point

An access point is a device that connects wireless devices together to create a wireless network. An AP usually connects to a wired network, and can relay data between wireless and wired devices. APs operate on a selected channel (1 to 11) and broadcast their name (SSID) to allow connection by wireless devices.

Ad-hoc wireless network

A wireless network between two wireless capable devices (normally PCs), where no wireless access point is involved.

ARP = Address Resolution Protocol

Used to determine Ethernet (MAC) address when a device starts to communicate with another. The host wishing to obtain a physical address broadcasts an ARP request and the device responds with its MAC address so further communication can be specifically addressed between the two.

DHCP = Dynamic Host Configuration Protocol -

Communications protocol where a range of IP addresses are managed centrally and assigned automatically to network devices on demand. A DHCP server is not required on a WLAN, but if it does not exist, all the devices on the WLAN must be manually configured. The Wi-Net Window reports the following from the DHCP server:

- an IP address for itself (My IP)
- the IP address of the DHCP server
- the Netmask in use
- the Router's IP address
- the IP address of the DNS server

DNS = Domain Name Server

Provides translation of URL addresses (like www.yahoo.com) to IP addresses. DNS servers are found on the Internet, and thus are of interest to the Wi-Net Window because accessing (pinging) the DNS server proves that the Wi-Net Window can access a device on the WLAN.

Gateway = Router - see below

IP = Internet Protocol

Actually TCP/IP = Transmission Control Protocol/Internet Protocol, but commonly abbreviated to IP.

Communications addressing scheme defined by DARPA (Defense Advanced Research Projects Agency) to control the publicly accessed Internet network.

IP Address

Specific number assigned to a single device to allow it to be uniquely identified on the network to which it is connected. On a WLAN, the IP address must be within the range of addresses defined for that WLAN by the Network Mask in use. On the Internet, all IP addresses must be universally unique to allow addressing that specific device. IP addresses consist of 4 hexadecimal digits that are commonly written in “dotted decimal” format. 192.168.254.4 is an example. Note that each set of decimal numbers divided by the periods must be in the range of 0-255 as they represent hexadecimal values of 00-FF.

ISP = Internet Service Provider

Commercial supplier of access mechanisms for public access to the Internet.

MAC Address = Media Access Control Address

Hardware serial number that uniquely identifies a device on a WLAN.

Netmask = Network Mask = Subnet Mask

Network Mask = Subnet Mask

IP addressing scheme that divides the entire IP address network into smaller sections (Subnets.) The Network mask is used to identify an IP address as being located either on the WLAN or on the Internet.

PING = Packet Internet Groper

A simple communication protocol (ICMP Echo) used to request an echo back from an addressed device (target). The Wi-Net Window uses this to verify IP connectivity between itself and another device.

Router = Gateway

Routers are located at gateways, the places where two or more networks connect. A wireless router forwards data packets across the WLAN, typically to the Internet. A router has an IP address and MAC address of its own for direct communications, which differentiates it from a HUB or SWITCH. A hardware box sold as a router will usually include a HUB or SWITCH chip inside, providing a convenient connection point for multiple Ethernet devices.

SSID - Service Set Identifier

A unique network name that identifies a wireless network.

Target

In the Ping protocol, an IP address must be selected to receive an echo request. This address is the “target” address for that Ping. A target IP address may be selected manually in Setup. This target can be on the WLAN, or anywhere else accessible through a router connected to the WLAN. If the target is not on the LAN, the router IP address must be known so the Ping can be sent to the router which forwards it on toward the ultimate location.

WLAN = Wireless Local Area Network

A Wireless LAN is a computer network that connects workstations and personal computers for the purposing of communicating with each other and to share data and devices, such as laser printers, faxes, and data storage devices.

Specifications

Physical Dimensions: (with antenna)

Size: 18.4 x 7.6 x 3.8 cm

7.25 x 3.0 x 1.5 in

Weight: (with antenna and battery)

370 grams (13 oz)

Environmental:

Operating temperature:

0 to 50°C (32 to 122°F)

Storage Temperature:

-20 to 60°C (-4 to 140°F)

Humidity:

10% to 90%, non-condensing

Battery Type: 4 AA Alkaline or Nickel-Metal Hydride batteries

Battery Life: 4 AA Alkaline batteries used continuously in one of the following modes:

Standby: 2.5 years

Testing: 22 hours

Maintenance

The Wi-Net Window may be cleaned with a damp cloth. If heavy accumulations of dirt are present, a small amount of liquid soap may be applied to the cloth to assist in cleaning. Do not use solvents, scouring powders, or other abrasive cleaners as they may damage the polycarbonate lens over the LCD screen.

Warranty

Test-Um Inc. guarantees that its products will be free of all defects in material and workmanship. This warranty extends for a period of 12 months from the date of manufacture or proof of purchase. All Wi-Net Windows deemed defective under this warranty will be repaired or replaced at Test-Um's discretion. No further warranties either implied or expressed will apply, nor will responsibility for the operation of this device be assumed by Test-Um Inc.



WEEE Compliant: Prior to disposal of this product, please contact Test-Um Inc. for proper disposal options.

Returning Equipment

To return a Wi-Net Window, you must obtain a Return Merchandise Authorization (RMA) number from Test-Um's Customer Service department by calling (805) 383-1500 or emailing support@test-um.com. The RMA number must be marked on the shipping label or container.

Shipping

1. Ship the equipment with a copy of the sales receipt, if available.
2. Attach a description of the operational problem.
3. Include a contact name, phone number, and email address.
4. Pack securely to prevent damage during shipping.
5. Ship prepaid to:
Test-Um Inc.
Att: RMA XXXX
808 Calle Plano
Camarillo, CA 93012-9396

Test-Um Inc.

The Intelligent Test Solutions Company

808 Calle Plano

Camarillo, CA 93012

(805) 383-1500 / FAX (805) 383-1595

www.Test-Um.com