



DESCRIPTION

The IF-D98 is a very high-speed photologic detector housed in a “connector-less” style plastic fiber optic package. The detector contains an IC with a photodiode, linear amplifier and Schmitt trigger featuring an PECL logic compatible totem-pole output. Optical response of the IF-D98 extends from 400 to 1050 nm, making it compatible with a wide range of LED and laser diode sources. The detector package features an internal micro-lens, and a precision-molded PBT housing ensures efficient optical coupling with standard 1000 μm core plastic fiber cable.

APPLICATION HIGHLIGHTS

The fast transition times of the IF-D98 make it suitable for high-speed digital data links. Link distances in excess of 75 meters at data rates of 155 Mbps are possible using standard 1000 μm core plastic fiber and an IF-E99 LED. The integrated design of the IF-D98 provides simple, cost-effective implementation in a variety of digital applications.

APPLICATIONS

- PC-to-Peripheral Data Links
- Motor Controller Triggering
- Ethernet LANs
- Medical Instruments
- Automotive Electronics
- Digitized Video and HDTV
- Sonet/SDH Receivers
- Robotics Communications
- Isolation from Lightning and Voltage Transients

FEATURES

- ◆ No Optical Design Required
- ◆ Mates with Standard 1000 μm Core Jacketed Plastic Fiber Cable
- ◆ Internal Micro-Lens for Efficient Coupling
- ◆ Inexpensive Plastic Connector Housing
- ◆ Connector-Less Fiber Termination and Connection
- ◆ Interference-Free Transmission from Light-Tight Housing
- ◆ Totem-Pole Output

MAXIMUM RATINGS

($T_A = 25^\circ\text{C}$)

Operating Temperature Range (T_{OP})	-20° to 70°C
Storage Temperature Range (T_{STG})	-40° to 85°C
Soldering Temperature (2 mm from case bottom) (T_S) $t \leq 5s$	240°C
Supply Voltage, (V_S)	-5 to 7 V
Power Dissipation (P_{TOT}) $T_A = 25^\circ\text{C}$	250 mW
De-rate Above 25°C	1.7 mW/°C

CHARACTERISTICS ($T_A = 25^\circ\text{C}$)

Parameter	Symbol	Min	Typ	Max	Unit
Peak Sensitivity	λ_{PEAK}	-	800	-	nm
Spectral Sensitivity (S=10% of S_{MAX})	$\Delta\lambda$	400		1050	nm
Operating Voltage	V_{CC}	4.75	5	5.25	V
Supply Current	I_{CC}	-	-	40	mA
Light Required to Trigger 1, 2, 3, 4, 5 ($V_{CC} = 5\text{ V}$, $\lambda = 660\text{ nm}$)	$E_r (+)$	-	6.3 -22	-	μW dBm
High Level Output Voltage 1, 2, 5 ($I_{OH} = -1\text{ mA}$)	V_{OH}	3.9	-	4.3	V
Low Level Output Voltage 1, 2, 5 ($I_{OL} = -0.5\text{ mA}$)	V_{OL}	2.9	-	3.4	V
Output Rise and Fall Times 1, 2, 5	t_r, t_f	-	-	3	ns
Data Rate 6, 7	f_D	4	-	156	Mbps
Pulse Width Distortion	Δt	-3	-	3	ns
Jitter	Δt_j	-	-	3	ns

NOTES:

1. Input signal at 156 Mbps (Bi-phase signal)
2. 3 pF capacitor as load (including parasitic capacitance such as probes, connectors, and PCB patterns)
3. Optical input waveform is generated with IF-E99 LED
4. Average value, measured using plastic fiber (MH4001 by Mitsubishi Rayon)
5. 3 k Ω resistor externally connected to Q and \bar{Q}
6. Bi-phase signal; NRZ conversion
7. No transition with DC light, no light, and modulated light below 4 Mbps

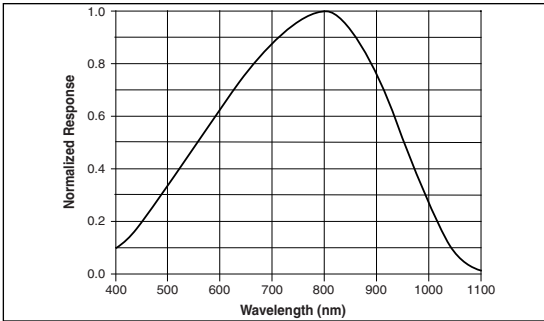

FIGURE 1. Typical detector response versus wavelength.

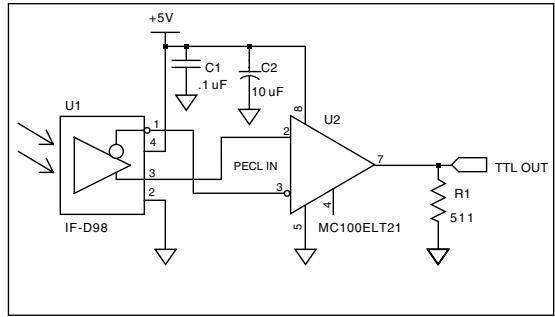

FIGURE 3. Typical interface circuit.

T B D

FIGURE 2. Normalized threshold irradiance vs. amb. temp.

FIBER TERMINATION INSTRUCTIONS

1. Cut off the ends of the optical fiber with a single-edge razor blade or sharp knife. Try to obtain a precise 90-degree angle (square).
2. Insert the fiber through the locking nut and into the connector until the core tip seats against the internal micro-lens.
3. Screw the connector locking nut down to a snug fit, locking the fiber in place.

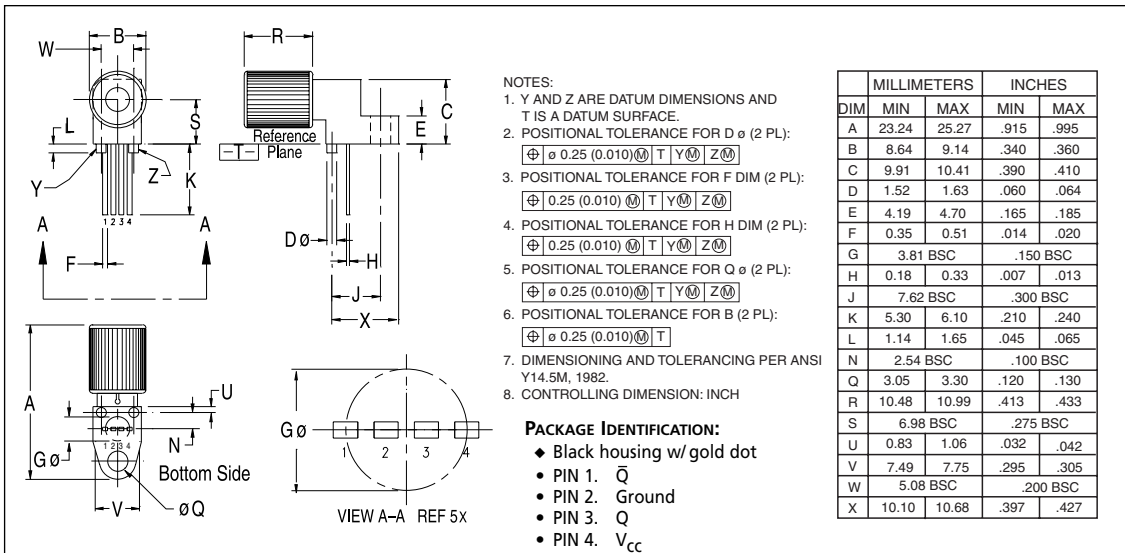

FIGURE 4. Case outline.