

Conversion Instructions

Conversion from Atmel AT90S2313-10SI to the AT90S2313-10PI

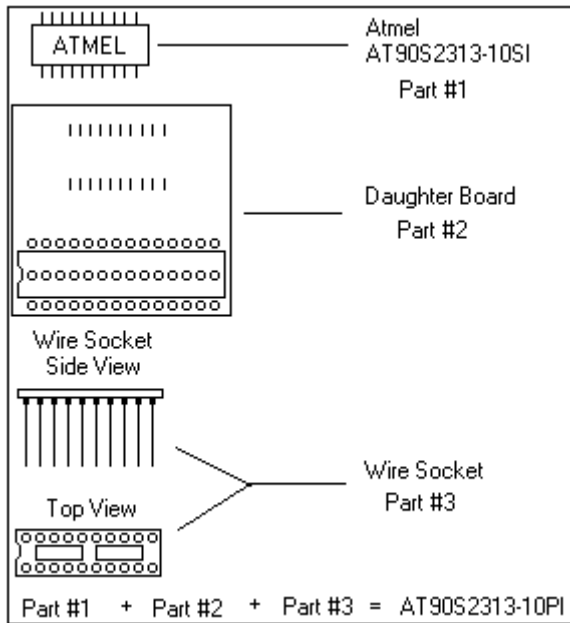

1. Take Part #2 and put solder on the edge of the lead area.

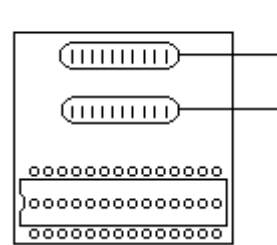

2. Put a piece of tape over part of the Atmel chip so that you can tape it to the Daughter board.

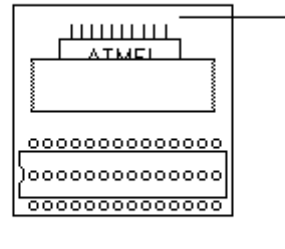

3. Next Solder the leads to the board. Once the leads are soldered down on one side remove the tape and solder the other side.

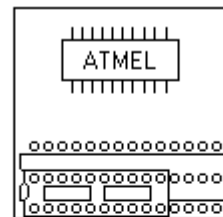

Side View



4. Next put the wire socket through the daughter board and solder the pins in place from the bottom of the board.