

PROGRAMMABLE POWER SUPPLY

Operating Manual

Programmable Power Supply

CSI3645A user's manual

Caution.....	2	Chapter 2 Operation.....	7
Safety notes.....	2	2.1 General operation	7
Chapter 1 General Introduction	3	2.2 Function introduction.....	7
1.1 General Introduction.....	3	2.2.1. Main functions.....	7
1.2 Specification.....	3	2.2.2 Sub-functions.....	7
1.3 Features	4	2.3 The operation of the function.....	7
1.4 Dimension and Structure.....	4	2.3.1 V-set.....	8
1.4.1 Dimension.....	4	2.3.2 I-set.....	9
1.4.2 Structure.....	5	2.3.3 Switch ON/OFF power output.....	9
1.4.2.1 Front view	5	2.3.4 Store data function.....	10
1.4.2.2 Back view.....	6	2.3.5 Recall data function.....	11
		2.3.6 The function of the Menu.....	12
		2.3.6.1 Set up the maximum voltage output value (0~36V).....	12
		2.3.6.2 Set up the key sound.....	13
		2.3.6.3 Set up the communication.....	13
		2.3.6.4 Set up communication address (0~254).....	13
		2.3.6.5 Set up locking key board.....	13
		2.3.6.6 Set up constant power output.....	14
		2.3.6.7 Set up save option.....	14
		2.3.6.8 Exit function.....	14
		Chapter 3 System Installation.....	15
		3.1 System Installation.....	15
		3.2. System Start.....	17
		Chapter 4 The Function Introduction.....	18
		4.1 Users' Login.....	18
		4.2 The Definition of the Power Supply.....	18
		4.3 The COM Port and Lower Machine (Power Supply) Address Set.....	19
		4.4 Run the Communication.....	20
		4.5 Stop the Communication.....	20
		4.6 Select POWER.....	21
		4.7 Select PC to POWER Control Instructions.....	21
		4.8 Set the Voltage Range.....	21
		4.9 Set the Max Current.....	21
		4.10 Users' Manage.....	23
		4.11 Query the Report.....	24
		4.12 Explanation of the Interface Indicating Components.....	25
		4.13 The State Bar.....	26
		4.14 Help.....	25
		4.15 Logout User.....	26
CONTENTS			

CAUTION

Before switching on the DC Power supply, the protective earth terminal of this instrument must be connected to the protective conductor of the AC line power cord. The AC line plug shall be inserted only in a socket outlet provided with a ground. The ground may be lost by use of an extension cord (or power cable) without a protective grounding conductor.

SAFETY NOTES

The following general safety precautions must be observed during all phases of operation, service, and repair of this instrument. Failure to comply with these precautions or with specific warnings elsewhere in this manual violates safety standards of design, manufacture, and intended use of the instrument. The Manufacturer assumes no liability for the customer's failure to comply with these requirements.

Ground the Instrument

This product is provided with a protective earth terminal. To minimize shock hazard, the instrument chassis and cabinet must be connected to an electrical ground. The instrument must be connected to the AC power supply mains through a three-conductor power cable, with the third wire firmly connected to an electrical ground (safety ground) at the power outlet. For instruments designed to be hard-wired to the AC power lines (supply mains), connect the protective earth terminal to a protective conductor before any other connection is made. Any interruption of the protective (grounding) conductor or disconnection of the protective earth terminal will cause a potential shock hazard that could result in personal injury. If the instrument is to be energized via an external autotransformer for voltage reduction, be certain that the autotransformer common terminal is connected to the neutral (earthed pole) of the AC power lines (supply mains).

Keep Away From Live Circuits

Operating personnel must not remove instrument covers. Component replacement & internal adjustments must be made by qualified service personnel. Do not touch or replace components with power cable connected.

Under certain conditions, dangerous voltages may exist even with the power cable removed. To avoid injuries, always disconnect power, discharge circuits and remove external voltage sources before touching components.

Do Not Substitute Parts or Modify Instrument

Because of the danger of introduction additional hazards, do not install substitute parts or perform any unauthorized modification to the instrument. Return the instrument to a qualified dealer for service and repair to ensure that safety features are maintained.

Chapter 1 General Introduction

1.1 General Introduction

CSI3645A-Type programmable DC power supply is designed and manufactured by ARRAY Electronic Co., Ltd. for Circuit Specialists, Inc. The CSI3645A is a high quality mini-size DC programmable power supply with a professional appearance. It is equipped with a back-lit LCD display, numeric keypad & rotary code switch for ease of use. Voltage, current and power can all be displayed on the LCD or a computer (with optional RS-232 adaptor). It can be operated at constant current mode, constant voltage mode & constant power mode. Also it can be set to maximum limits for current & power outputs. It is an essential instrument for scientific research, education, test labs, or any environment requiring a sophisticated DC power source.

1.2 Specification

Type	3644A	3645A	3646A
Output	1	1	1
Output voltage	0~18V	0~36V	0~72V
Output current	0~6A	0~3A	0~1.5A
Voltage resolution	1mV at 0~3.999V 5mV at 4~18V	1mV at 0~3.999V 10mV at 4~36V	1mV at 0~3.999V 20mV at 4~36v
Current resolution	<=1mA		
Ripple	<=3mVpp		
Communication	RS232/RS485 *		
Monitor software	Free software VC++ / VB / DELPHI / LABVIEW / COM parts		
Memory	10 points EEPROM		
Protective mode	Over voltage /over current /over power		
Power voltage	AC 110/220 available (60/50HZ)		
Weight	5.5Kg		
Accessories	Software, users manual, AC power cable, handlebars		
Purchase Option Parts	Communication adaptor module for RS232 Mounting rack		

1.3 Features

1. LCD display with back light.
2. Number keypad.
3. High resolution at 1mv.
4. Protection for over or low voltage.
5. Protection for over or low current.
6. Adjustable voltage and constant voltage output.
7. Adjustable current and constant current output.
8. Can be set for maximum current protection.
9. Can be set by number key or rotary code switch.
10. Power shut-down memory function
11. Monitored by PC software (requires optional RS-232 module).
12. Mini-size and light weight.
13. Can be used in series connect and parallel connect modes.

1.4 Dimension and Structure

1.4.1 Dimension

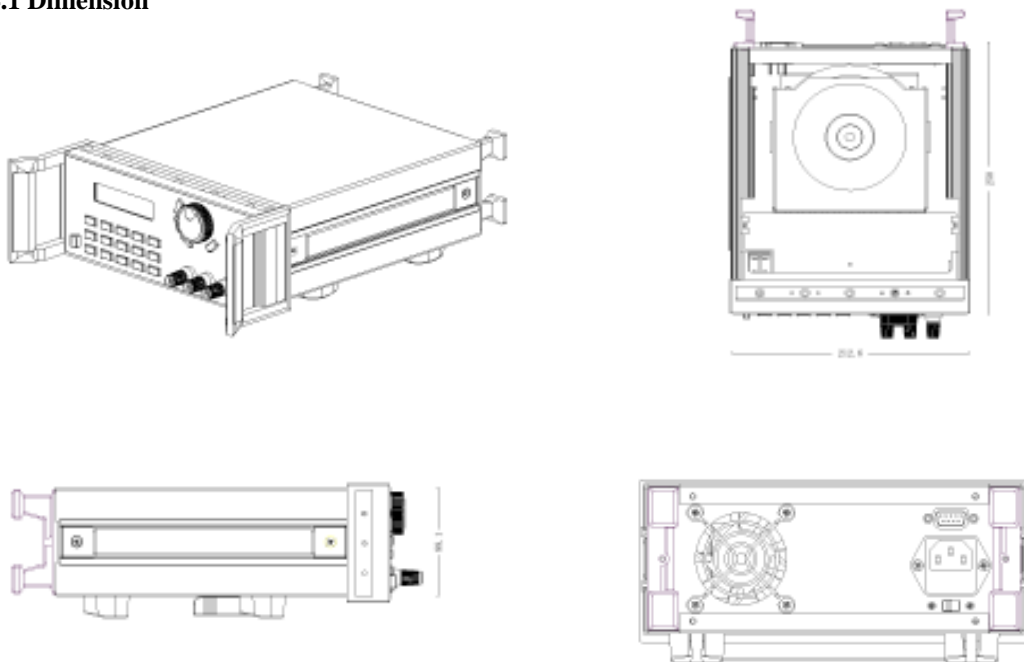

Fig 1 Dimension of CSI3645A Programmable DC power supply

1.4.2 Structure

1.4.2.1 Front view

Front panel is for users to operate, and there is one LCD display, one number keypad and one rotary keypad. Please see the following picture.

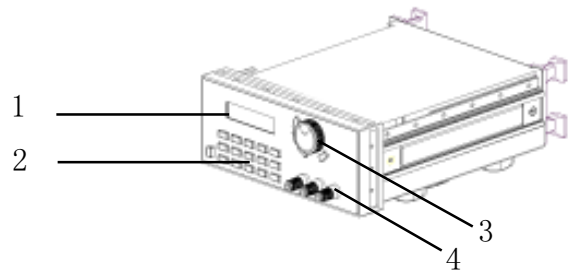

Fig2. Front view of CSI3645 DC power supply

1. LCD display

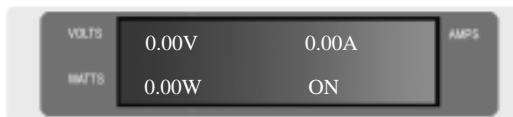

Fig3. LCD Display of CSI3645 power supply

The Left-upper Conner:

Set voltage value.
(Flashing voltage means low-voltage.)

The Left-bottom Conner:

Output power value.
(Flashing power value means over power.)

The Right-upper Conner:

Output current value.

The Right-bottom Conner:

State:
ON(OFF)
represents the output state of the power supply .
PC(KEY)
represents the operation of the keypad or the computer.

2. Arrangement of the Keyboard

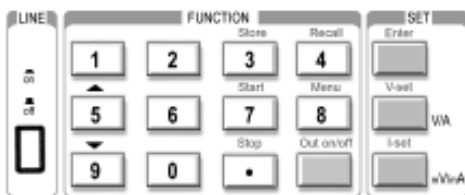

Fig4. Keyboard of CSI3645 DC power supply

In common state, the keyboard will execute the prompting functions of the black words. And in special mode, it will change into the functions of the orange colored words.

0~9: The number keys

Store: Save the current setting value

Recall: Read the saved setting value

Menu: The menu operation key

OUT ON/OFF: Start/Stop the output

Enter: The confirmation key

V-set: The output voltage value set

I-set: The max output current set

▲ : The up moving key

▼ : The down moving key

V/A: Represent V at the voltage mode, represent A at the current mode.

mV/ mA :Represent mV at the voltage mode, and represent mA at the current mode

3. Rotary code switch and function keys



Left Operation: The left moving key

Right Operation: The right moving key

ESC: Can be used to exit any working state

OK: Confirmation key

Rotary SW: The rotation key

Fig5. Rotary and function keys

1.4.2.2 Back view

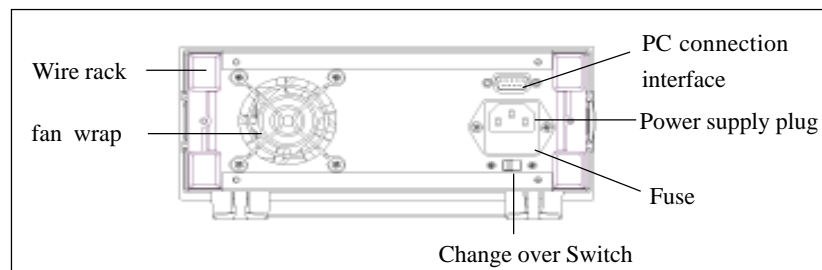

Fig 6 Back view

The fuse can be changed easily by using a small screw driver. Please use a fuse within the range of 2~2.5A.

Chapter 2 Operation

2.1 General operation

1. Connect the power supply with a PC

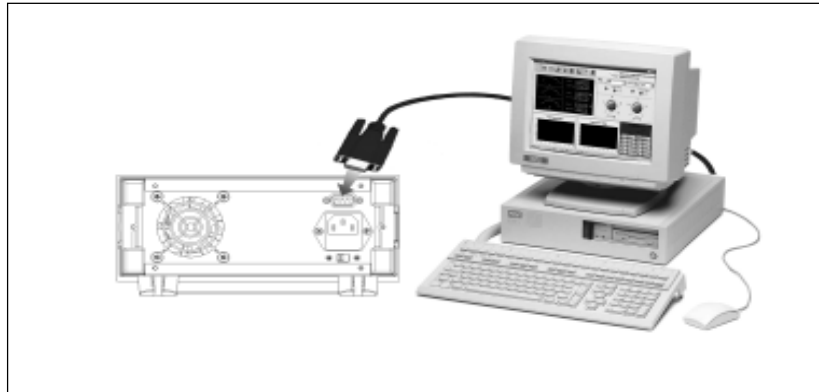

Fig 7 Connect the power supply with PC

2.2 Function introduction

2.2.1. Main functions

1. Set up a constant voltage from 0 to 36V
2. Set up a constant current or maximum protection current from 0 to 3A
3. Switch ON/OFF the power supply output
4. Store 10 sets of data which can be set up
5. Recall the stored data

2.2.2 Sub-functions

1. Set up maximum protection voltage
2. Turn ON/OFF the sound of key
3. Set up the communication
4. Lock keyboard ON/OFF
5. Set up the maximum power
6. Save the last set up voltage

2.3 The operation of the function

We know that there are 4 main functions and 6 sub-functions of this power supply, the following will describe how to operate all of the functions. Before any operation, please connect the power, and switch the power on. A power -on indicator will light.

2.3.1 V-set (set up a constant voltage from 0 to 36V)

Setting up a constant DC voltage output is the first main function of programmable DC power supply. The CSI3645A provides two methods to set up the constant DC voltage output by using the number keyboard or the rotary button. Please see the following operation procedure.

Procedure	Operation details	LCD display
Step 1	Press "V-set"	24.00V 0.00A 0.00W ON
Step 2	Enter the password (Or jump to step 4 if the keyboard is unlocked)	ENTER PASSWORD
Step 3	Press "Enter" button (it will return to step 2 if your password is wrong for reentering)	ENTER PASSWORD ****
Step 4	Press "V-set" to enter the original value which displayed on the LCD, or enter a new value by using the number key or rotate "Rotary SW" to adjust the voltage value and then press the "V-set" button for confirmation	SET VOLT= 24.00V NEW=
Step 5	Press "V/mV" button to change the voltage unit into mV, it will return to step 4 for reentering if the current voltage exceed the high limited value	SET VOLT= 24.00V NEW= 18
It will exit the setting up voltage operation at any procedure by press ESC button		

Example: Setting the output voltage at 24.3V

1. Set up by using the number keyboard

- Step1. Press "V-set" button,
- Step2. Enter the password by using the number keyboard (if the keyboard is unlocked, please do step 4),
- Step3. Press Enter button (if the password is wrong, please do step 2 for reentering),
- Step4. Press "2", "4", "." and "3" button to enter the voltage value,
- Step5. Press "V-set" button to confirm the voltage value.

2. Set up by using the Rotary SW

(1) If the keyboard is unlocked by password, directly rotate the "Rotary SW" button, and the voltage will be continually changed from the previews value according the rotation. At the beginning, the cursor will be shown on the last number of the value which is indicated on the LCD, you can move the cursor to the first number, second number etc by using "◀" and "▶" buttons, and then rotate to change each number, and let it stay at 24.3 V, then confirm the value by pressing "V-set" button.

(2) If the keyboard is locked by password

- Step1. Press "V-set" button,
- Step2. Enter the password by using the number keyboard,
- Step3. Press Enter button (if the password is wrong, please do step2 for reentering),
- Step4. Rotate the Rotary SW button to change the value, the operation is as the same as above(1)
- Step5. Press "V-set" button to confirm the voltage value.

2.3.2 I-set (set a constant current or a maximum current from 0 to 3A)

CSI3645A power supply can be set for a constant current or a maximum current from 0 to 3A. There are two special applications for users when setting the I-set. Please see the following example.

Conditions: voltage=24V, load R=12 Ω , then V/R=2 A, it represent that the power supply provide the load 2A current. If

1)Set up the current I = 2.5A, then the current should be displayed on the screen as 2A.

2)Set up the current I = 1A, then the current should be displayed on the screen as 1A. It means that the power supply provides load 1A current.

Set up current procedure is as following:

Procedure	Operation details	LCD display
Step 1	Press "I-set"	24.00V 0.00A 0.00W ON
Step 2	Enter the password (Or jump to step 4 if the keyboard is unlocked)	ENTER PASSWORD
Step 3	Press "Enter" button (it will return to step 2 if your password is wrong, for reentering)	ENTER PASSWORD ****
Step 4	Press "I-set" to enter the original value which displayed on the LCD, or enter a new value by using the number key or rotate "Rotary SW" to adjust the current value and then press the "I-set" button for confirmation,	SET CURR=0.00A NEW=1.2
Step 5	Press "A/mA" button to change the voltage unit into mV, it will return to step 4 for reentering if the current exceed the high limited value of 3A	SET CURR=0.00mA NEW= 15.0
User may exit the set current operation at any point by pressing the ESC button		

2.3.3 Switch ON/OFF power output

The output of CSI3645A should be off when it is powered, users can change the output status by using ON/OFF button. The button is a turn over button, when the original output is ON, press the button, then the output will be changed to OFF status, when the original output is OFF, press the button, then the output will be changed to ON status.

2.3.4 Data store function

This function makes the CSI3645A very easy to use. If you want to use a constant voltage and current (such as 24V and 2A, or 12V and 2.3A etc) every day, you just need to set up the data for the first time, and then store the data in the power supply, and then recall it when you need the data again. CSI3645A can store up to 10 sets of data.

The stored contents include 1) Voltage value; 2) Current value; 3) Maximum voltage; 4) Locked/unlocked key board; 5) Maximum power ; 6)Baud rate; 7) Communication address.

The data store function is always done after setting up V-set, I-set etc. The operation is as follows:

Procedure	The operation Methods	LCD display
Step 1	Press "Store" button	****V ****W ****A **
Step 2	Enter the password (Or jump to step 4 if the keyboard is unlocked)	ENTER PASSWORD
Step 3	Press "Enter" button (it will return to step 2 if your password is wrong for re-entering)	ENTER PASSWORD 1234
Step 4	Enter the set value to store number(from 1 to 10) by using the number key-pad or rotate the rotary button to change the set value number for storage	STORE 1
Step 5	Press "Store" button to confirm the set value, if the number is out of the range from 1 to 10, it will return to Step 2 for re-entry.	STORE *
You may exit the data store function at any point by pressing the ESC button		

For example: To set up the voltage=15V, current=2A, Maximum output voltage=18V, key board locked, Maximum output power=25W, Baud rate=9600, communication address=05, after doing the setup , users can store all the above as a set of data, such as the 01 or 02 etc.

2.3.5 Recall data function

The CSI3645A can store up to 10 sets of data in the power supply memory

Also, any single data set can be easily recalled from the memory. This means that you do not need to set up again for repetitive requirements. Users can enhance the benefits of the CSI3645A & recall one set of data from the stored data sets, including set up of 1) Voltage value; 2) Current value; 3) Maximum voltage; 4) Locked/unlocked key board; 5) Maximum power ; 6) Baud rate; 7) Communication address.

The recall operation is as follows:

Procedure	The operation Methods	LCD display
Step 1	Press "Recall" button	0.000V 0.00A 0.00W OFF
Step 2	Enter the password (Or jump to step 4 if the keyboard is unlocked)	ENTER PASSWORD
Step 3	Press "Enter" button (it will return to step 2 if your password is wrong for reentering)	ENTER PASSWORD 1234
Step 4	Enter the number of the set data which you want to recall (from 1 to 10) by using the number key or rotate the rotary button to change the number you want recalled.	RECALL 1
Step 5	Press "Recall" button to confirm , if the number is out of the range from 1 to 10, it will retune to Step 2 for re-entry	RECALL *
You may exit the Recall operation at any point by pressing the ESC button		

2.3.6 The Menu function

The CSI3645A power supply provides a Menu operation for some special functions. The operation and function are as follows.

Procedure	The operation Methods	LCD display
Step 1	Press “Menu” button	0.000V 0.00A 0.00W OFF
Step 2	Enter the password (Or jump to step 4 if the keyboard is unlocked)	ENTER PASSWORD
Step 3	Press “Enter” button (it will return to step 2 if your password is wrong for reentering)	ENTER PASSWORD 1234
Step 4	The LCD displays the menu functions one by one. User can use the UP and DOWN button to select each function, Press “Enter” button to execute the selected function	MAX OUT VOLTAGE KEY SOUND SET COMMUNICATION SET ADDRESS SET KEY LOCK MAX OUT POWER SAVE SET EXIT
You may exit the Menu operation at any point by pressing the ESC button		

The menu operation includes MAX OUT VOLTAGE, KEY SOUND SET, COMMUNICATION SET, ADDRESS SET, KEY LOCK, MAX OUT POWER, and Save set function. We will describe the details as follows.

2.3.6.1 Set up the maximum voltage output value (0~36V)

When you select the MAX OUT VOLTAGE function, the LCD will display as:

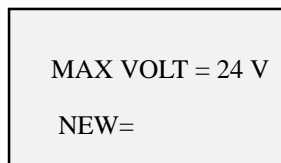

You can set the voltage value by using the UP and DOWN key or rotating the ROTARY button. Then confirm the value by pressing “Enter” button.

2.3.6.2 Set up the key sound

When you select the KEY SOUND SET function, the LCD will display as:

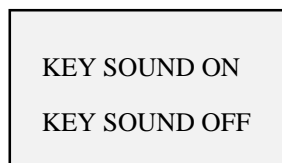

Users can select KEY SOUND ON or KEY SOUND OFF by using UP and DOWN key button. KEY SOUND ON represent the sound of keys will be on , and KEY SOUND OFF represent the sound of keys will be off.

2.3.6.3 Communication set up

This function is for monitoring the output data of the power supply by using a computer.

When you select COMMUNICATION SET function, the LCD will display as:

```
BUAD RATE=4800
BUAD RATE=9600
BUAD RATE=19200
BUAD RATE=38400
```

Users can change the communication setup by using UP and DOWN keys or rotating the ROTARY button, and confirm the value by pressing "Enter" button.

BUAD RATE 4800 represent BUAD rate=4800bps

BUAD RATE 9600 represent BUAD rate=9600bps

BUAD RATE 19200 represent BUAD rate=19200bps

BUAD RATE 38400 represent BUAD rate=38400bps

2.3.6.4 Set up communication address (0~254)

This communication address function is for monitoring multi-power supply system. In the system, one computer can monitor 255 power supplies at the most by the connecting RS232 and 485 bus. So we should give each power supply an address.

When you select ADDRESS SET function, the LCD will display as:

```
SET ADDRESS =12
NEW=
```

Users can change the communication address value by using UP and DOWN keys or rotating the ROTARY button, and confirm the value by pressing "Enter" button. The range of the address value is from 0 to 254.

2.3.6.5 Set up locking keyboard

After you locked the keyboard, you must enter the correct password to unlock it, then you can use the number keys and the ROTARY button. This function is for the safety & security.

When you select the KEY LOCK function, the LCD will display as:

```
ENTER PASSWORD
```

Users can enter 4 numbers or letters as the password by pressing the number button or by using ? and ? buttons or ROTARY button to change the number or ASCII number which will be your password, and confirm the password by pressing the "Enter" button.

2.3.6.6 Set up constant power output (the range is from 0 to 108 W)

When you select the MAX POWER function, the LCD will display as:



MAX POWER=56 W
NEW=

Users can change the power value by using UP and DOWN keys or rotating the ROTARY button, and confirm the value by pressing the “Enter” button. The range of the power value is from 0 to 108W.

2.3.6.7 Set up SAVE OPTION

This function is for saving the last set up of the voltage output. It is a convenient & time saving feature when the same voltage value is needed repeatedly. It will display the same voltage value when the power supply is powered up.

When you select the SAVE OPTION function, the LCD will display as:



SAVE VOLTAGE
DON T SAVE VOLT

Users can change the selection by using UP and DOWN keys or rotating the ROTARY button, and confirm the selection by pressing “Enter” button. To select SAVE VOLTAGE means to save the last set up voltage, to select DON T SAVE VOLT means not to save the last set up voltage value.

2.3.6.8 EXIT function

When the EXIT function is selected, you will exit the Menu operation.

Chapter 3 System Installation

3.1 System Installation

3.1.1 Put the disk into the CDROM drive. Then the system will run automatically and the initial diagram as in Fig. 3-1 will be displayed.



Fig.3-1 The Installation Initial Interface

3.1.2 Then it will enter the interface as in Fig. 3-2. Press “NEXT” to continue.

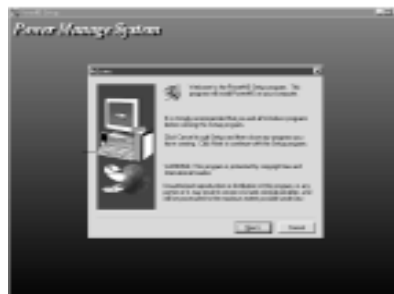

Fig. 3-2 The Installation Interface 2

3.1.3 In Fig. 1-3, there is some explanation to some products' introduction. Read it and press “YES” to continue. This must be done to continue with the installation.



Fig. 3-3 The Installation Interface 3

3.4 In Fig. 3-4, click “BROWSE” to select installation directory path. The default directory path is “C:\Program Files\Array\PowerMS”



Fig. 3-4 The installation Interface 4 The Installation Directory Path Set

3.1.5 In Fig. 3-5, users may select the installation type. Generally, select “TYPICAL” and click “NEXT” to continue.



Fig. 3-5 The Installation Interface 5

3.6 In Fig. 3-6, enter the file folder's name and the default name is “POWERMS”. Generally it is not needed to enter and it is just need to click “NEXT”.



Fig. 3-6 The Installation Interface 6

3.1.7 Click “NEXT” and the installation system will enter the files' copying state. Please wait patiently for the end of the files' copying. Then the PowerMS system installation is finishing.



Fig. 3-7 The Installation Interface 7 The Files' Copying

3.2. System Start

3.2.1 In Fig. 3-8, select the file folder of “Start | Program | Array”. And then click the “PowerMS” in the menu.



Fig. 3-8 The System Start Interface

3.2.2 Enter the initial interface as shown in Fig. 3-9.



Fig. 3-9 The System Start Diagram

3.2.3 Wait for the end of the system initialization and then it will enter the main interface as shown in Fig. 3-10.

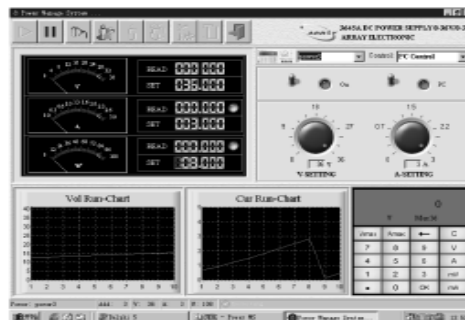

Fig. 3-10 The PowerMS Main Interface

Explanation:



1. Every time the PowerMS system is started, it will automatically be in minimized state. And at this time the icon  is in the state bar on the desk. Click the right key of the mouse on the icon, the menu as shown in Fig. 3-11 will be displayed.



Fig. 3-11

- “Show”: Show the interface.
 - “Hide”: Hide the interface.
 - “Start Communicate”: Start the communication.
 - “Stop Communicate”: Stop the communication.
 - “About PMS”: Show the help contents.
 - “Exit System”: Close the system. (And users must register before.)
2. If the system is started from the program file folder, it will be at the maximized state.

3. System Uninstallation

It is only need to select “” in the program file folder. And it must be done after the closing of the system otherwise there will be no way to uninstall.

Chapter 4 The Function Introduction

4.1 Users' Login

When the system is first entered, it is set to be in the lowest limit of authority state. At this time, only the COM port set and the POWER selection can be carried out, and other functions cannot be used. So users must login and operate and it guarantees the security of the system.

Select the icon  and the interface as shown in Fig. 4-1 will be displayed. After the first time installation, the system will provide for two users: the “Manager” and the “Lowest” for you to select. Selecting “Manager”, entering the password “0001” and then clicking “OK”, in this way the system will have all the functions.

Explanation: “Manager” is the user(s) of with management authority; “Lowest” is for user(s) with the lowest limit of authority. the two user levels are retained by the system.

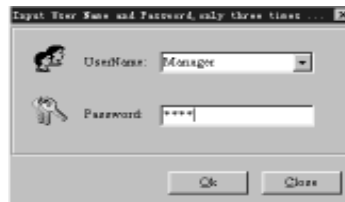



Fig.4-1 The User Login Interface

4.2 The Definition of the Power Supply

Select the function item  and then the interface as shown in Fig. 4-2 will be displayed.

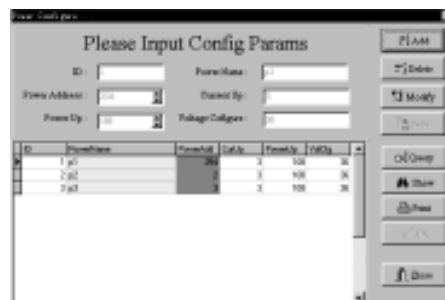

Fig. 4-2 The Power Definition Interface

Add: Select "Add" in the function items and then input the contents of each item. After the set of the input, select "Save" to save it.

Delete: Select the POWER record to be deleted in the table and then select "Delete". Finally select "Save" and it will be deleted.

Modify: Select the POWER record to be modified in the table and then select "Modify" to modify it. After the modification, select "Save" and it will be modified.

Query: Select "Query" and then wait for the name of the power supply to be queried.

Show: Select "Show" and it will show all the records.

Print: Select "Print" and it will print all the current records.

Parameter Explanation

Parameter	Explanation	Range	Remarks
Power Name	Name Of the Power Supply		Must be Input
Current Up	The Max Current	0~3A	Must be Input
Power Up	The Max Power	0~108W	Must be Input
Voltage Configure	The Max Voltage	1~36V	Must be Input
Configure			
ID	The ID Number		No Consideration

Notes: When selecting the "Add" function item to add POWER, the name and address of the POWER cannot be repeated. After entering all the information, click "OK" and the dialogue frame as shown in Fig. 4-3 will be displayed. In Fig.4-3, select "YES" and the system will close and restart.

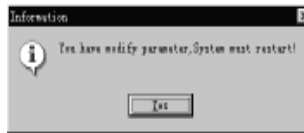

Fig. 4-3 System Prompt the restart

4.3 The COM Port and Lower Machine (Power Supply) Address Set

Login in the identity of "Manager" and then select the quick icon after the system restarts. The dialogue frame as shown in Fig.4-4 will be displayed.

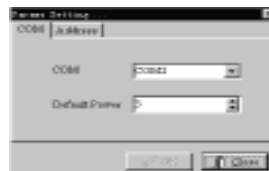

Fig. 4-4 COM Port and address set

In Fig. 4-4, select the page key "COM" and select the COM port from the pull-down table. If the COM port does not exit, the system will prompt the diagram as shown in Fig. 4-5. And the "OK" button and the page key "ADDRESS" are out of work. And vice versa. (user must be "Manager" status, otherwise the "ADDRESS" cannot be used.



Fig. 4-5 COM Port Failure Opening Dialogue Frame

Set Default POWER Address:

The system will automatically be in the networking state after the start according to the default COM port and the default POWER. It is just needed to enter the address in the “Default POWER” bar.

Set POWER Address:

Login in the identity of the “Manager” and select the existing COM port. Then the “ADDRESS” page key will be available.

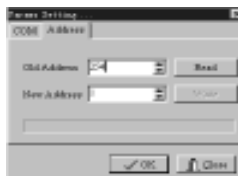

Fig. 4-6 POWER Address Set

In Fig. 4-6, enter the default address (245) of the lower machine and then click “READ”. If testing successfully, the “NEW ADDRESS” and “WRITE” functions will be available. If testing failure, then the new address of the power cannot be set and the prompting diagram as shown in Fig. 4-7 will be displayed. This time the communication cable must be checked.



Fig. 4-7 Communication Failure

Explanation: For the first time installation each POWER must be deployed with but one address so as to communicate correctly. Set the parameter and select “OK” and it will enter into the common communication. The default COM port is COM1 and the default POWER address is 1.

4.4 Run the Communication

After the COM port and ADDRESS set, select the button  and the system will start the communication. If the communication is normal, the prompting information as shown in Fig. 4-8 will be displayed. And if the communication has failed, the prompting information as shown in Fig. 4-9 will be displayed.



Fig. 4-8 Normal Communication



Fig.4-9 Failed Communication

4.5 Stop the Communication

Select the button  and the system will stop communication.

4.6 Select POWER

In Fig. 4-10, select the POWER name from the listing frame and it will be set.



Fig. 4-10 Selecting the POWER

4.7 Select PC to POWER Control Instructions

1.) Methods 1

As in Fig. 4-11, there are four control instructions in total.

CLOSE POWER	OPEN POWER
PC CONTROL	POWER SELF



Fig. 4-11-1 Select the Control Instruction

Explanation: The system default control instruction is the PC CONTROL state. And when the system is closed or the POWER is switching, the system will automatically set to POWER SELF state.

2.) Methods 2



Fig. 4-11-2 Selecting Control Instruction

4.8 Set the Voltage Range

There are two methods to set the voltage range: one is by using the rotary button (1~36) and the other is by using the keyboard (0.004~36.000). If you want to set accurately, please use the keyboard. In general state, you can use the rotary button.



Fig. 4-12 Using the Rotary Button



Fig. 4-13 Using the Keyboard

- 1) Using the rotary button: Move the mouse to the icon and then rotate the button.
- 2) Using the keyboard: Select the “V” button, enter the data and then select the “OK” button.

4.9 Set the Max Current

There are two methods to set the voltage range: one is by using the rotary button (1~36) and the other is by using the keyboard (0.004~36.000). If you want to set accurately, please use the keyboard. In general state, you can use the rotary button.



Fig. 4-14



Fig. 4-15

- 1) Using the rotary button: Move the mouse to the icon  and then rotate the button.
- 2) Using the keyboard: Select the “A” button, enter the data and then select the “OK” button.

Note: Authority above “General” must be used for this setting.

4.10 Users’ Manage

For the security of the system, the manager must set a login user name and a password for each operator. (This can only be done by the manager.)

Select the button  and the interface as shown in Fig. 4-16 will be displayed.

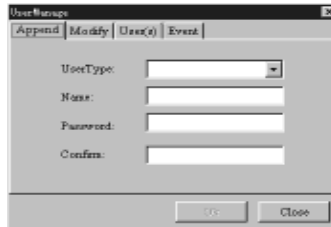

Fig. 4-16 Users Manage

1.) Append User

Select the page key “APPEND” and the user type (generally is “General”). Enter the user’s name (cannot be blank) and the password twice (must be the same) and then click “OK”.

Explanation: “General” is the general user; “Lowest” is the user of the lowest limit of authority.

2.) Modify the User’s Name and Password

In Fig. 4-17, select the user name and enter the password. Then enter a new user name (cannot be blank) and a new password twice (must be the same). After entering, press “OK”.

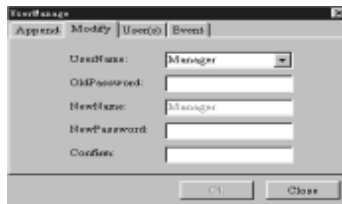

Fig. 4-17 Modify the Password and the Name

Explanation: The user “Lowest” is retained by the system and cannot be modified.

3.) Query User(s)

Select the page key “USER(S)”, the dialogue frame as shown in Fig. 4-18 will be displayed.

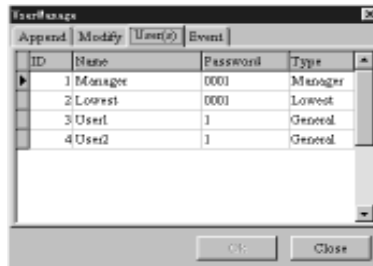

Fig. 4-18 Query the User(s)

If you want to delete a user, select the user from the listing table and click “Delete”. Then the confirmation dialogue frame will be displayed for you to confirm. In Fig. 4-19, if you select “YES”, the user will be deleted. And if you select “NO”, the deletion will be cancelled.



Fig. 4-19 Deleting User Prompting

Note: “Manager” and “Lowest” are retained by the system and cannot be deleted.

4.) Event

Select the page key “EVENT” and the dialogue as shown in Fig. 4-20 will be displayed. It is mainly used to query the users’ login and logout times so as to manage conveniently. If you want clear records, select “CLEAR” and “YES” in the prompting confirmation dialogue frame.



Fig. 4-20 Clearing Data Prompting

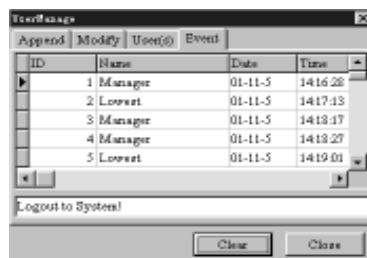

Fig. 4-21 User Operating Information

Click the right key of the mouse and query according to the users’ name or date. And the following dialogue will be displayed.

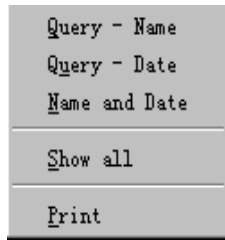



Fig. 4-22

Query – Name: Query according to the user’s name.
 Query – Date: Query according to the date.
 Name and Date: Query according to the name and date.
 Show all: Show all the information about the users.

4.11 Query the Report

Select the button  and the diagram as shown in Fig. 4-23 will be displayed.

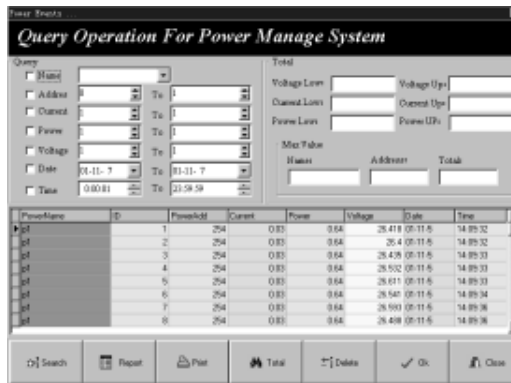

Fig. 4-23 Query the Report

- 1.) Set the Query Conditions: Set the parameters in the “Query” frame.
- 2.) Query: After setting the conditions, select “SEARCH” button and all the records agreed with the conditions will be listed.
- 3.) Set the Report: Select “REPORT” and it will be OK.
- 4.) Print the Report: Select “PRINT” and it will be OK.
- 5.) Query Totally: Select “TOTAL” and it will be OK. The date range must be selected and the other conditions cannot be selected. Its main function is to analyze several POWER so as to list the POWER that overflow the most data. The overflowing data includes the voltage overflowing, the current overflowing and the power overflowing.
- 6.) Delete the History Record: Select “DELETE” and the diagram as shown in Fig. 4-24 will be displayed. If you confirm to delete, select “YES” and it will be OK.



Fig. 4-24 Delete the History Data

Explanation: The date range condition must be set.

7.) Close: Select "CLOSE" and return to the upper-interface.

4.12 Explanation of the Interface Indicating Components

1.) Instrument Part

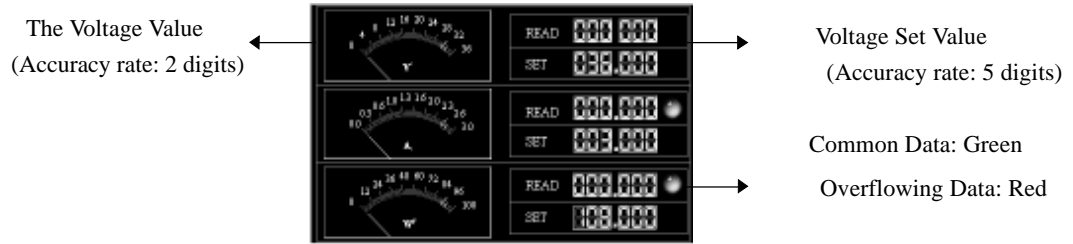
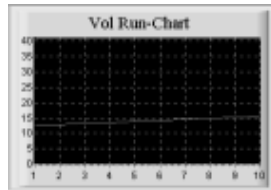

Fig. 4-25 Instrument Indication

Common Date and Overflowing Data are both in the normal communication state.

2.) Running Curve: Indicates the data acquired at the nearest 10 ports.

4.13 The State Bar



The Voltage Running Diagram

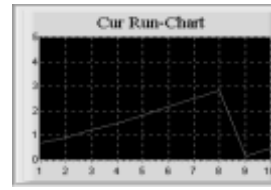

The Current Running Diagram

3.) Keyboard Explanation



Fig. 4-26
Keyboard Explanation

- Number Keys: 0-9 “.”: the point key
- “C”: the clearing key “←”: the backspace key
- “V”: the voltage setting key (Unit: V 0~36.000)
- “A”: the current setting key (Unit: A 0~3.000)
- “mV”: the voltage setting key (Unit: mV 0~36000)
- “mA”: the current setting key (Unit: mA 0~3000)
- “Vmax”: input the max voltage value (36V)
- “Amax”: input the max current value (3A)
- “OK”: the confirmation key

Panel Part:

- V: presents the current voltage set state (Unit: V).
- Max 36: presents that the max set voltage value is 36.
- 0: the current set value

4.14 Help



Power: p3: presents the current selected POWER.

- Add: 3: presents the POWER address.
- V: 36: presents the defined voltage max value.
- A: 3: presents the defined current max value.
- W: 108: presents the defined power max value.
- Sending: presents the operation state.

4.15 Logout User





Click the icon  and the help diagram as shown in Fig. 3-26 will be displayed.



Fig. 4-27 Help Interface

Select the icon  and the system will automatically be in the lowest limit of authority. User must login again for the operation. When leaving, the user must carry out the canceling operation, especially the manager.

4.16 Power Supply State Indication

- | | |
|------------------------------------|---|
| 1. Overloading current indication: |  |
| Blue presents normal. | Red presents overloading. |
| 2. Overloading power indication: |  |
| Blue presents normal. | Red presents overloading. |
| 3. Power supply ON/OFF state |  |
| Blue presents OFF. | Red presents ON. |
| 4. Power supply control type: |  |
| Blue presents CONROL SELF. | Red presents PC CONTROL. |

4.17 Exit the System

Select the icon . To do this, you must login first, otherwise the system cannot be closed.