

4 . 5 Digit Autoranging Bench Top Multimeter



Users Manual

Contents

Contents	I
Chapter 1	1
Safety Standards	1
Warning	1
Warranty	2
Chapter 2	3
Introduction and Specifications.....	3
Front Panel	3
Rear Panel	7
LCD Display Description.....	8
Function Descriptions	9
Chapter 3 Operation Manual	10
Understanding AC Zero Input Behavior of True RMS Meters	10
DC/AC(TRMS) Voltage	10
DCmV/ACmV.....	11
Ohm/Continuity/DIODE	13
Capacitance Measurement.....	14
Logic Frequency/Duty cycle Measurement.....	15
Clamp Measurement	16
Temperature measurement	17
DC μ A / AC μ A measurement.....	18

DC mA / AC mA measurement	19
DC A / AC A measurement.....	20
Linear Frequency Measurement	21
Relative Measurement.....	22
Max/Min Value.....	23
Data Hold	23
Low Passed Filter	23
Peak Value	24
RS232 Interface.....	24
Auto Power Off	24
Chapter 4 Specification	25
General Specification	25
Range and Accuracy	25
Chapter 5 Maintenance	31
Introduction	31
Replacing the Fuse	31
Replacing the Power Fuse	32
Replacing the Battery	32
Chapter 6 Accessories.....	33

Chapter 1

Safety Standards

This style of digital multimeter is designed and manufactured according to the safety requirements set out by the IEC61010-1 standards for electronic test instruments . Its design and manufacture is strictly based on the provisions in the 1000V CAT II of IEC61010-1 and the Stipulation of 2-Pollution Grade.

Warning

To avoid possible electric shock, personal injury, or death, read the following before using the Meter:

- Use the Meter only as specified in this manual, or the protection provided by the Meter might be impaired.
- Do not use the Meter in wet environments.
- Inspect the Meter before using it. Do not use the Meter if it appears damaged.
- Inspect the test leads before use. Do not use them if insulation is damaged or metal is exposed. Check the test leads for continuity. Replace damaged test leads before using the Meter.
- Verify the Meter's operation by measuring a known voltage before and after using it. Do not use the Meter if it operates abnormally. Protection may be impaired. If in doubt, have the Meter serviced.
- Whenever it is likely that safety protection has been impaired, make the Meter inoperative and secure it against any unintended operation.
- Have the Meter serviced only by qualified service personnel.
- Do not apply more than the rated voltage, as marked on the Meter, between the terminal or between any terminal and earth ground.
- Always use the power cord and connector appropriate for the voltage and outlet of the country or location in which you are

working.

- Remove test leads from the Meter before opening the case.
- Never remove the cover or open the case of the Meter without first removing it from the main power source.
- Never operate the Meter with the cover removed or the case open.
- Use only the replacement fuses specified by the manual.
- Use the proper terminal, function and range for your measurements.
- Do not operate the Meter around explosive gas, vapor or dust.
- When using probes, keep your fingers behind the finger guards.
- When making electrical connections, connect the common test lead before connecting the live test lead. When disconnecting, disconnect the live test lead before disconnecting the common test lead.
- Disconnect circuit power and discharge all high voltage capacitors before testing resistance, continuity, diodes, or capacitance.
- Before measuring current, check the Meter's fuses and turn OFF power to the circuit before connecting the Meter to the circuit.
- When servicing the Meter, use only specified replacement parts.

Warranty

The meter is warranted to be free from defects in material and workmanship under normal use and service. The warranty period is one year and begins on the date of shipment. Parts, product repairs, and services are warranted for 18 months except for misused, altered, neglected, contaminated, or damaged by accident or abnormal conditions of operation or handling. This warranty does not apply to fuses, disposable batteries.

Chapter 2

Introduction and Specifications

- 22000 Counts
- ACV and DCV up to 1000V
- 10 μ V Sensitivity for Voltage measurement.
- Linear Frequency 、 Logic Frequency and Duty Measurement
- Capacity Range from 0.01nF to 220mF
- AC TRMS.
- Peak Max/Min value Measurement Function
- Max/Min, Relative Measurement Function
- Low Passed Filter Function
- RS-232 Optical Isolation Interface(It can communicate with PC by connecting R3415 cable via USB socket,R3415 cable optional)
- PC Software for Display Data Record and Data Analysis
- Power Supply Methods: 220V/110V AC(50~60Hz)、 9V 6F22 Battery、 1.5 \times 6 AA Battery
- Temperature Measurement
- Clamp Measurement

Front Panel

Front panel as below:

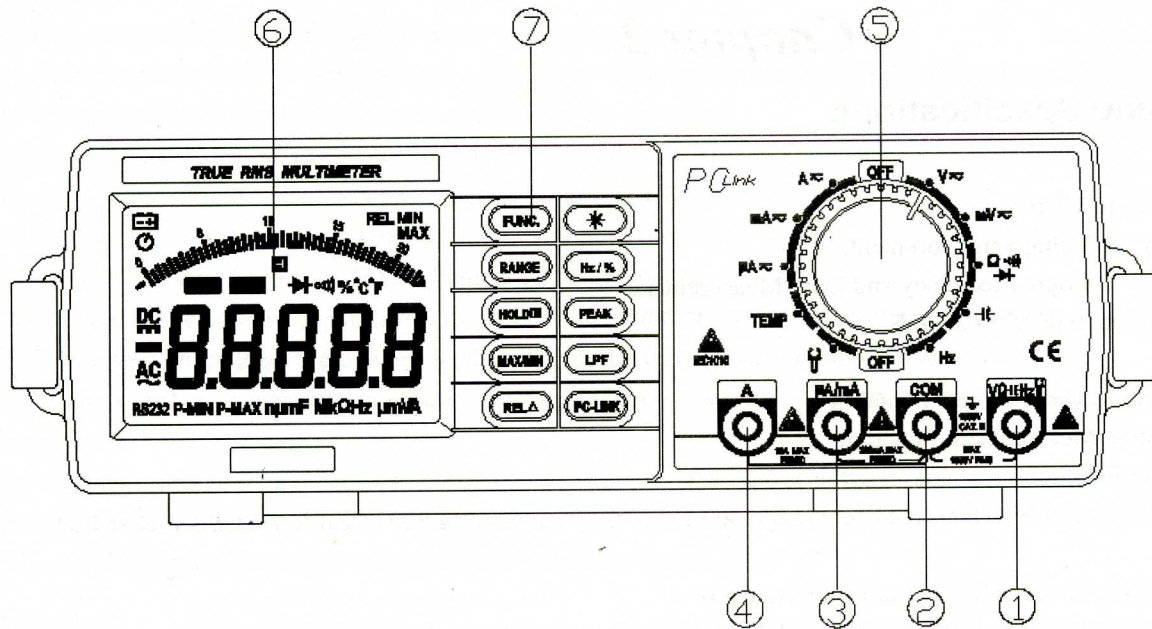

Front Panel Features

1. **V Ω Hz Terminal**
Input positive terminal for all measurement except current measurement , connected with red test leads.
2. **COM Terminal**

- Input common terminal for all measurement , connected with black test leads.
- 3. **μ A/mA Terminal**
Input positive terminal for current measurement (μ A/mA) , connected with red test lead.
- 4. **A Terminal**
Input positive terminal for current measurement (A) , connected with red test lead.
- 5. **Rotary Switch**
Switching positions correspondingly when changing different input signals.
Note: Switching position before changing signals in case caused damage.
- 6. **Display Screen**
- 7. **Button**

Button Description

Name	Description
FUNC	Function toggling
	Back Light (Wake up) , press this button can wake the meter in auto power off mode
RANGE	Toggle to manual mode in autorange mode , increase range in manual mode; toggle to autorange mode when pressing longer than 1 S in manual mode.
Hz	Under frequency measurement, toggle from frequency to duty.
HOLD	Select hold function., when the measuing value overload ,Display 'OL';
PEAK	Select peak function: The peak values are stored in external Capacitors.
MAX/MIN	Select max/min function: The meter displays the maximum or minimum value.
LPF	To activate the low passed filter function, most of noise above 1KHz will decay greatly.
REL Δ	LCD panel displays relative value.
PC-LINK	LCD panel displays 'RS232' , the meter communicates with PC software.

FUNC button description

Rotary Position	Input Signal
$V \sim$	DCV \leftrightarrow ACV
$mV \sim$	DCmV \leftrightarrow ACmV
$\Omega \rightarrow \cdot \cdot \cdot \rightarrow \rightarrow$	$\Omega \rightarrow \cdot \cdot \cdot \rightarrow \rightarrow$
\cup	DCA \leftrightarrow ACA
TEMP	$^{\circ}C \leftrightarrow ^{\circ}F$
$\mu A \sim$	DC μ A \leftrightarrow AC μ A
$mA \sim$	DCmA \leftrightarrow ACmA
$A \sim$	DCA \leftrightarrow ACA

Button description

	RANGE	HOLD	MAX/MIN	REL		Hz	PEAK (Note 2)	LPF	PCLINK (Note 1)
Voltage	<input type="radio"/>	<input type="radio"/>	<input type="radio"/>	<input type="radio"/>	<input type="radio"/>	<input type="radio"/>	<input type="radio"/>	<input type="radio"/>	<input type="radio"/>
Current	<input type="radio"/>	<input type="radio"/>	<input type="radio"/>	<input type="radio"/>	<input type="radio"/>	<input type="radio"/>	<input type="radio"/>	<input type="radio"/>	<input type="radio"/>
Clamp	<input type="radio"/>	<input type="radio"/>	<input type="radio"/>	<input type="radio"/> (AC)	<input type="radio"/>	<input type="radio"/>	<input type="radio"/>	<input type="radio"/>	<input type="radio"/>
Resistance	<input type="radio"/>	<input type="radio"/>	<input type="radio"/>	<input type="radio"/>	<input type="radio"/>	<input checked="" type="radio"/>			<input type="radio"/>
Capacitance	<input type="radio"/>	<input type="radio"/>	<input type="radio"/>	<input type="radio"/>	<input type="radio"/>	<input checked="" type="radio"/>			<input type="radio"/>
Frequency	<input checked="" type="radio"/>	<input type="radio"/>	<input checked="" type="radio"/>	<input checked="" type="radio"/>	<input type="radio"/>	<input type="radio"/>			<input type="radio"/>
Duty	<input checked="" type="radio"/>	<input type="radio"/>	<input checked="" type="radio"/>	<input checked="" type="radio"/>	<input type="radio"/>	<input checked="" type="radio"/>			<input type="radio"/>
Temperature	<input checked="" type="radio"/>	<input type="radio"/>	<input type="radio"/>	<input type="radio"/>	<input type="radio"/>	<input checked="" type="radio"/>			<input type="radio"/>

Note 1: In Capacitance Measuring mode ,when **MAX/MIN** or **REL** function is activated,the data sent to PC software is the actual value.

Note 2: When **PEAK** function is activated, the data sent to PC software is invalid

Note 3: ○ meaning the function can be selected, X menaing the function is invalid

Rear Panel

Rear panel as blow:

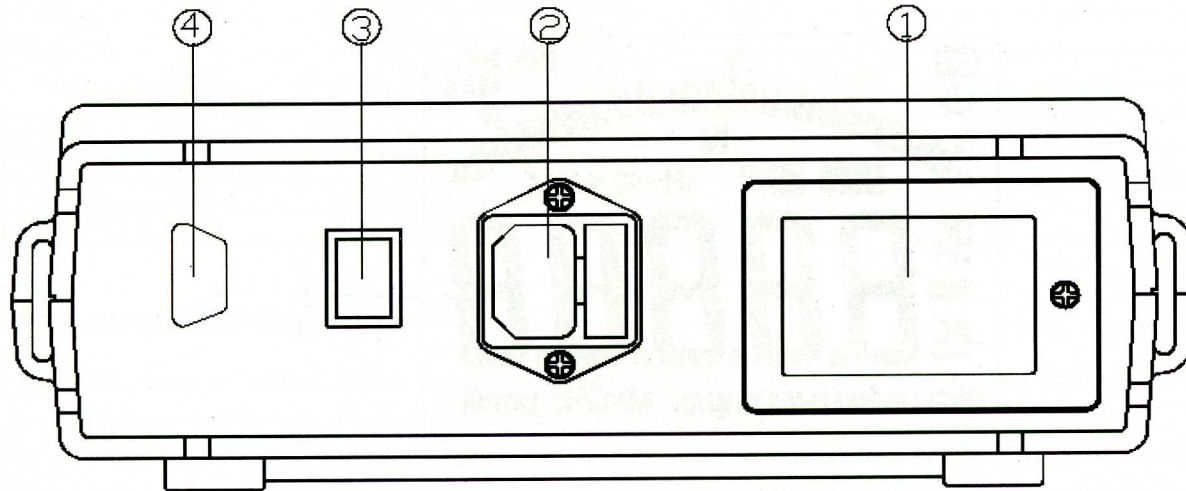

(1) Battery Cover

Replace 9V 6F22 or 1.5×6 AA battery.





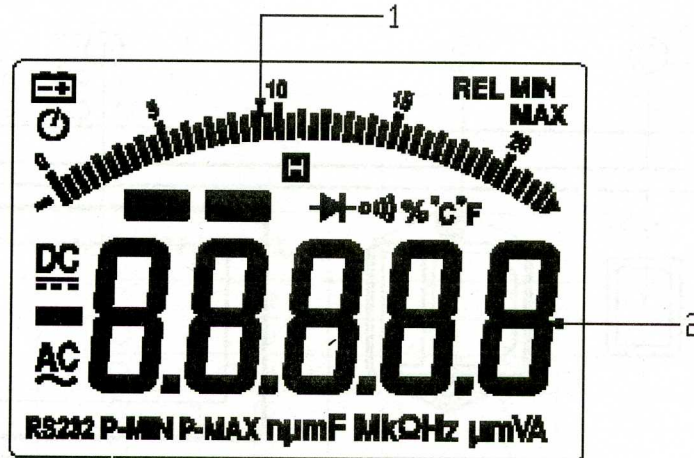

- (2) Supply Power Inlet with Fuse, Houses Fuse 0.1A/250V.
- (3) Power Switch
- (4) RS232 Socket

LCD Display Description



- (1) Bargraph Display Zone
- (2) Digital Display Zone

Display Annunciators and Indicators

Sign	Description
	Battery (low battery when shown on display.)
	Auto power off function is selected
	DC (Direct Current)
	AC (Alternating Current)
	Hold status is selected
	Diode test is selected
	Continuity test is selected
RS232	Communication with PC terminal is selected
P-MIN	Reading is minimum peak value
P-MAX	Reading is maximum peak value
REL	Relative readings function is selected
MIN	Reading is minimum value
MAX	Reading is maximum value

Function Descriptions

- Auto range or manual range: Toggle to manual mode in autorange mode , increase range in manual mode; toggle to autorange mode when pressing longer than 1 S in manual mode.
- Linear frequency : When input signal is AC voltage or current, press ‘Hz’ button to activate frequency measurement.
- Logic frequency and duty : In frequency mode, press ‘Hz’ button switches the mode to/from duty cycle mode.
- Continuity and diode test: Under continuity test , the beeper emits a continuous tone if the input is approximately below 30 Ω .Under diode test,the forward voltage of the semiconductor junction (or junctions) is measured.

- Relative measurement: Show the difference between actual value and the relative base.
Display Value = Actual Value — Relative Value.
- Max/Min: Show the minimum or maximum value recorded and the present measurement.
- Low passed filter: Most of noise above 1KHz will decay greatly. So obtain more stable and accurate readings on low frequency response.
- Peak hold: Hold Max and Min peak value.
- RS232 Interface.

Chapter 3 Operation Manual

Understanding AC Zero Input Behavior of True RMS Meters

True RMS Meters accurately measure distorted waveforms, but when the input leads are shorted together in the AC function the Meter displays a residual reading between 0 and 30 counts, When the test leads are open, the display reading may fluctuate due to interference, These offset reading are normal .they do not affect the meter's measurement accuracy over the specified measurement range.

DC/AC(TRMS) Voltage

The Meter is capable of measuring voltage up to 1000 V DC and 750 V AC.

To perform a voltage measurement:

1. Turn rotary switch to $V\approx$ position, LCD panel displays 'DC'; press **FUNC** button when measuring AC voltage, and LCD display 'AC';

2. Connect red test lead with **V Ω Hz** terminal and black test lead with **COM** terminal;
3. Connect test leads to test circuit;
4. The Meter selects the appropriate range in the autorange mode. The function and measurement are displayed;
5. By pressing the **RANGE** button, it is possible to select range manually. While displaying **OL** during manual range measurement, it is necessary to select a larger range. When **OL** displaying under the maximum range, it indicates the voltage exceeding 1000V,so it is necessary to remove both the red and black test leads from the measured circuit immediately.

Note: In case of probe hanging in the air, the voltage inducted by the testing line may cause unstable readings on the display screen, but that will not affect the accuracy of measurement.

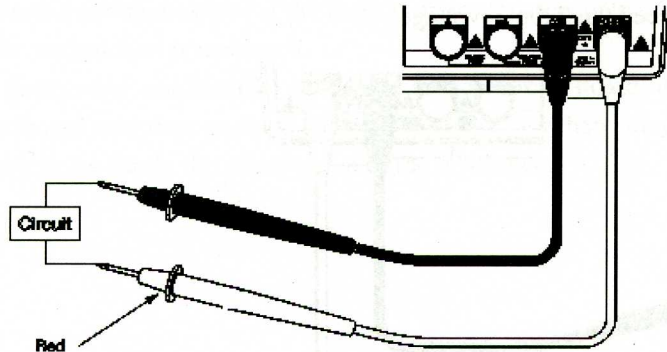

DCmV/ACmV

The Meter is capable of measuring mV up to 220mV.

To perform a mV measurement:

1. Turn rotary switch to $mV\approx$ position, LCD panel displays 'DC' ; press **FUNC** button when measuring AC mV, and LCD display 'AC';
2. Connect red test lead with **V Ω Hz** terminal and black test lead with **COM** terminal;
3. Connect test leads to test circuit;
4. The function and measurement are displayed;
5. While displaying **OL** during measurement, it is necessary to remove both the red and black test leads from the measured circuit immediately.

Notes: In case of probe hanging in the air, the voltage inducted by the testing line may cause unstable readings on the display screen, but that will not affect the accuracy of measurement.

Note: Do not measuring the voltage exceed the 220mV voltage.

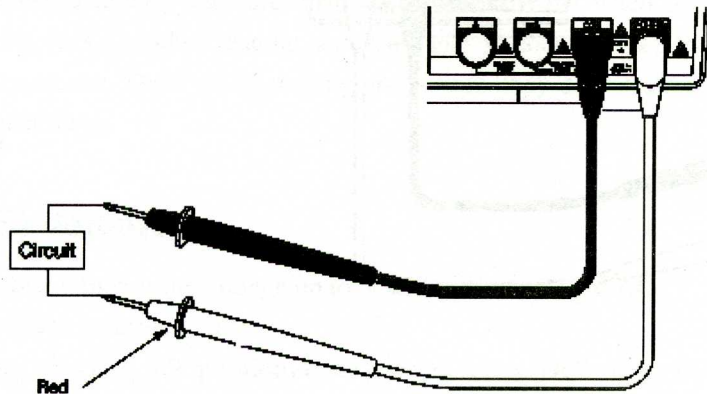

Ohm/Continuity/DIODE

The Meter is capable of measuring Ohm up to 220M Ω .

To perform a measurement:

1. Turn rotary switch to Ω position, LCD panel displays ' Ω ' ; press **FUNC** button to select continuity function or diode function;
2. Connect red test lead with **V Ω Hz** terminal and black test lead with **COM** terminal;
3. Press **FUNC** button selecting a function of the ohm, continuity or diode.
4. Connect test leads to test circuit;
5. The function and measurement are displayed;
6. The beeper emits a continuous tone if the input is approximately below 30 Ω .Under diode test,The forward voltage of the semiconductor junction is measured.

Note: In case of performing resistance or continuity test on circuit board, it is necessary firstly to turn off the power of the circuit board and then perform the measurement. As there may be other parallel circuits, so the displayed value of test is not surely the actual value of the resistance.

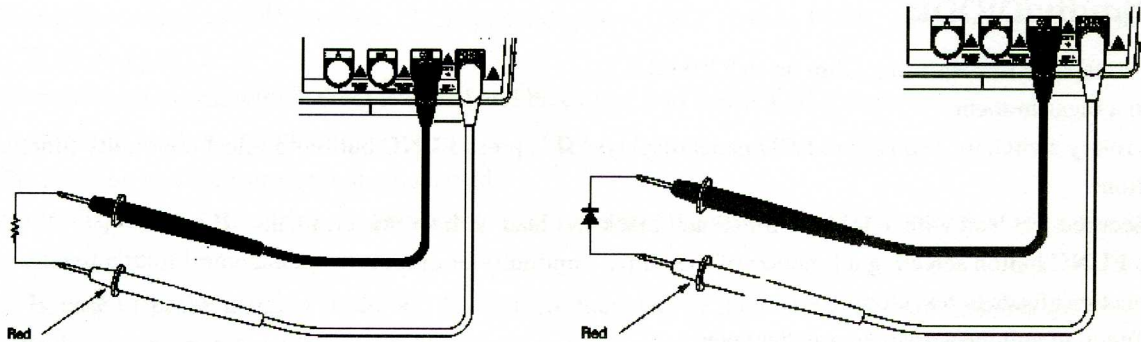

Capacitance Measurement

The Meter is capable of measuring up to 220mF

To perform a capacitance measurement:

1. Turn rotary switch to F position, LCD panel display 'F' ;
2. Connect red test lead with **V Ω Hz** terminal and black test lead with **COM** terminal;
3. Connect test leads to measure capacitance;
4. The function and measurement are displayed

Notes: 1). Discharge the capacitance before measuring.

2). Do not to perform capacitance measurement on a circuit board on which there are other parallel devices, for

that may cause a very large error.

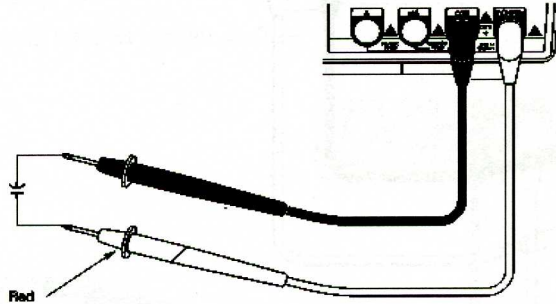

Logic Frequency/Duty cycle Measurement

The measurement frequency up to 220MHz (V_{pp} 3V), duty cycle range is of 10%~90%

To perform the measurement:

1. Turn rotary switch to **Hz** position, LCD panel displays '**Hz**' ;
2. Connect red test lead with **V Ω Hz** terminal and black test lead with **COM** terminal;
3. Connect test leads to measuring circuit;
4. Pressing **Hz** button to toggle between frequency and duty cycle measurement;
5. The function and measurement are displayed.

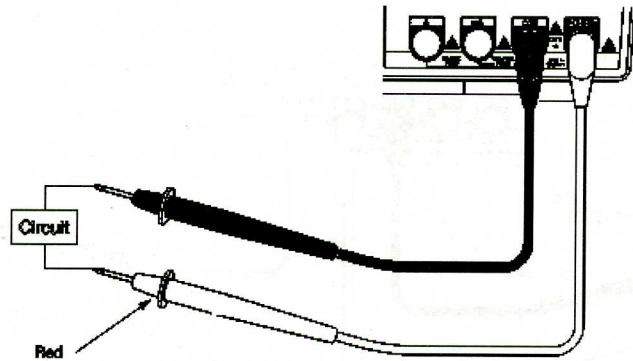

Clamp Measurement

The Meter is capable of measuring current up to 2200A

To perform the measurement:

1. Turn rotary switch to DC position, LCD panel displays 'DC'; press **FUNC** button when measuring AC Current, and LCD display 'AC';
2. Connect red test lead with **V Ω Hz** terminal and black test lead with **COM** terminal;
3. Connect test leads to clamp adapter's output terminal ;
4. The Meter selects the appropriate range in the autorange mode. The function and measurement are displayed;
5. By pressing the **RANGE** button it is possible to select range manually. While displaying **OL** during manual range

measurement, it is necessary to select a larger range. When **OL** displaying under the maximum range, it indicates the voltage exceeding 2200A,so it is necessary to remove both the red and black test leads from the adapter output terminal immediately.

Note: It is required clamp adapter output 1mV/A

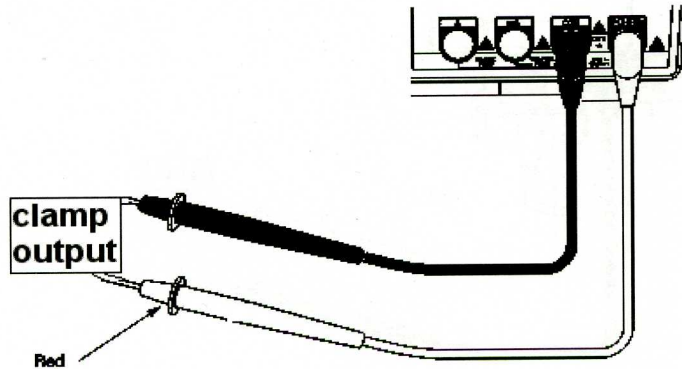

Temperature measurement

The Meter is capable of measuring temperature from -30°C to 1300°C

To perform the measurement:

1. Turn rotary switch to **TEMP** position, LCD panel default displays ambient temperature;
2. Connect Multi-Function socket **IN** terminal with **V Ω Hz** terminal ;Connect Multi-Function socket **COM** terminal with **COM** terminal;
3. Connect K type thermocouple to Multi-Function socket input terminal;

4. The function and measurement are displayed, it will display 'OL' if the measuring temperature is higher than 1300 °C or lower than -30 °C.

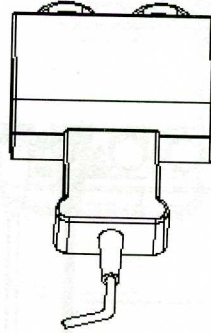

DC μ A / Ac μ A measurement

The Meter is capable of measuring current from 0.01 μ A ~ 2200 μ A

To perform the measurement:

1. Turn rotary switch to μ A \approx position, LCD panel displays 'DC'; press **FUNC** button when measuring AC Current, and LCD display 'AC';
2. Connect red test lead with μ A/m A terminal and black test lead with **COM** terminal;
3. Turn off the power of the measured circuit, connect the red and black probes to the measured circuit in serial way and then turn on the power of the measured circuit;
4. The Meter selects the appropriate range in the autorange mode. The function and measurement are displayed;

5. By pressing the **RANGE** button it is possible to select range manually. While displaying **OL** during manual range measurement, it is necessary to select a larger range. When **OL** displaying under the maximum range, it indicates the voltage exceeding $2200 \mu A$, so it is necessary to remove both the red and black test leads from the circuit immediately.

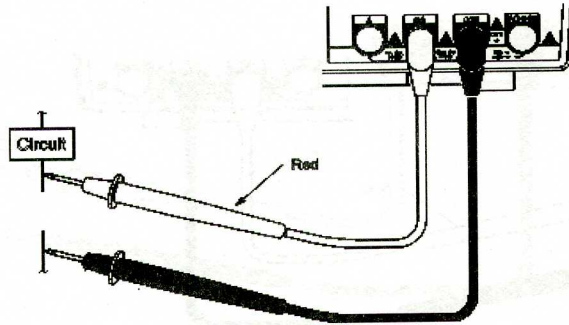

DC mA / AC mA measurement

The Meter is capable of measuring current from $1 \mu A \sim 220mA$

To perform the measurement:

1. Turn rotary switch to $mA \sim$ position, LCD panel displays 'DC'; press **FUNC** button when measuring AC Current, and LCD display 'AC';
2. Connect red test lead with $\mu A/m A$ terminal and black test lead with **COM** terminal;

3. Turn off the power of the measured circuit, connect the red and black probes to the measured circuit in serial way and then turn on the power of the measured circuit;
4. The Meter selects the appropriate range in the autorange mode. The function and measurement are displayed;
5. By pressing the **RANGE** button it is possible to select range manually. While displaying **OL** during manual range measurement, it is necessary to select a larger range. When **OL** displaying under the maximum range, it indicates the voltage exceeding 220mA,so it is necessary to remove both the red and black test leads from the circuit immediately.

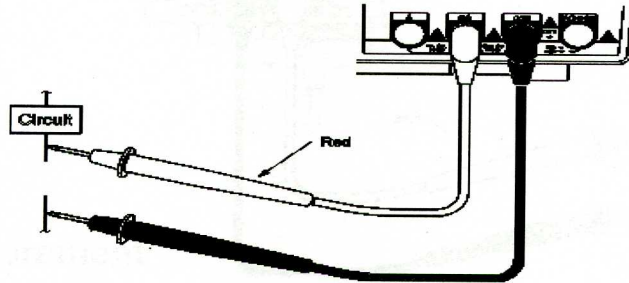

DC A / AC A measurement

The Meter is capable of measuring current from 0.1mA~10A

To perform the measurement:

1. Turn rotary switch to **A \approx** position, LCD panel displays 'DC' ; press FUNC button when measuring AC Current, and LCD display 'AC';
2. Connect red test lead with A terminal and black test lead with COM terminal;

3. Turn off the power of the measured circuit, connect the red and black probes to the measured circuit in serial way and then turn on the power of the measured circuit;
4. The function and measurement are displayed.

Note : Make sure the measurement current not exceed 10A to avoid damage of the meter.

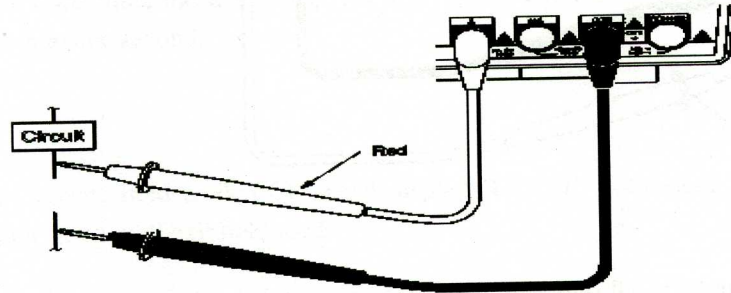

Linear Frequency Measurement

To perform the measurement:

1. When performing voltage or current measurement, in case of measured value being AC or including AC elements, it is possible to measure and display the frequency on the display zone, by pressing **Hz** key. However it has a certain requirements for the amplitude of alternating signal and the meter has varied requirements for signal amplitude when it is in different ranges, for information of which please refer to below;
2. Press **Hz** key again to measure duty.

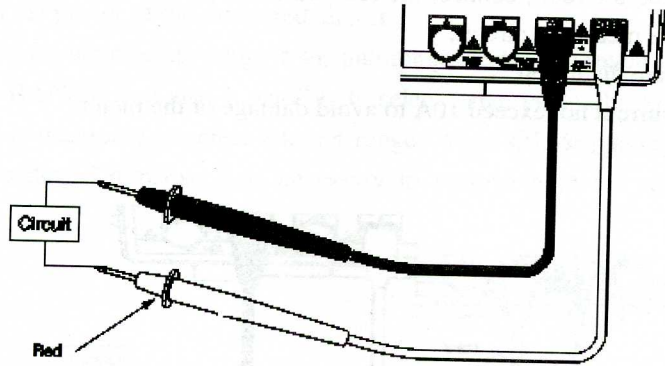

Relative Measurement

Except for frequency, duty, Clamp(AC), all other measurements can employ relative measurement. Press **REL Δ** key to enter relative measurement and the meter will record the initial value when pressing the key.

$$\text{Displayed value} = \text{Actual value} - \text{Initial value}$$

Press **REL Δ** again to exit relative measurement. Changes of measurement value may be found in relative measurement which also can be used for the small resistance measurements, for example, when performing resistance measurement, connect the red test lead and the black test lead in short, press the **REL Δ** key to record the values of resistance (resistance of both the red and black lines), and after that performing resistance measurement again the lead resistance will have been taken off from the display value.

Notes: Due to subtraction, the relative value is sometimes a negative one.

Max/Min Value

The meter displays the maximum or minimum value of the input in Max/Min mode. When **Max/Min** is pressed for the first time, the meter displays the maximum value. When **Max/Min** is pressed again, the meter displays the minimum value. When Max/Min is pressed for the third time, the meter displays max value. The meter returns to normal operation if Max/Min is pressed and held for longer than one second.

Data Hold

Pressing **HOLD** button to activate hold mode, LCD panel display '**HOLD**', hold mode makes the meter stop updating the LCD, pressing **HOLD** button again, will exit hold mode.

Low Passed Filter

The meter provides a 3-order low-pass filter to reduce the influence of high frequency noise above 1KHz (3dB). This LPF feature is available in all ACV measuring mode. Pressing **LPF** button to activate LPF function, in LPF mode, the '**AC**' sign on LCD panel will blink until the LPF mode is canceled. When LPF mode is activated, most of noise above 1KHz will decay greatly. So we can obtain more stable and accurate readings on low frequency response.; pressing LPF button again exit LPF mode.

Peak Value

The peak values are stored in external capacitors. The precision of Peak mode measurement can be enhanced by calibration. Calibration for Peak mode is invoked by pressing **Peak** button for more than 2 seconds. Entering Peak mode will automatically execute peak calibration. Pressing peak button, the meter display max peak value. Press **Peak** button again, the meter display min peak value, press peak button longer than 1S, the meter exits peak mode.

RS232 Interface

Connecting **RS232** terminal and PC socket with RS232C cable or R3415 cable in accessories, and press **PCLINK** Button, then the meter communicate with PC software, LCD display "**RS232**". PC can record, print the data from the meter by running PC software correspondingly. Press **PCLINK** button again, the meter terminate the communication with PC and don't display '**RS232**'.

Auto Power Off

The meter has a default auto power off function. If the meter is idle for more than 15 minutes, the meter automatically turns the power off; after power off, press  button to wake up the meter.

When the Sign RS232 is displayed, the meter will do not power off.

Chapter 4 Specification

General Specification

- 22000 counts, autorange / manual range, measurement rates of 2, 20 timers/second (slow, fast) .
- The max overload protective voltage is up to AC 250 V (TRMS)except for current and voltage.
In μ A/mA mode, protective current is 0.3A; In A mode, protective current is 10A.
- Overload Indicator: OL.
- Fuse : 0.3A/250V(μ A/mA terminal), 10A/250V(A terminal), 0.1A/250V(line power fuse)
- Optical Isolation RS232C Interface.
- Operating Temperature: $18^{\circ}\text{C} \sim 28^{\circ}\text{C}$ (relative humidity $\leq 80\%$)
- Storage Temperature: $-20^{\circ}\text{C} \sim 60^{\circ}\text{C}$ (relative humidity $\leq 80\%$)
- Temperature Coefficient: $0.05 \times \text{Specified Accuracy per } ^{\circ}\text{C}$ ($<18^{\circ}\text{C}$ or $>28^{\circ}\text{C}$)
- Dimensions: 238mm(W) \times 230mm(L) \times 83mm(H)
- Weight : Approx. 1.5kg, without power cord

Range and Accuracy

The below-listed accuracies under different ranges refer to those which are guaranteed by the meter within one-year calibration, under the operating temperature of $18^{\circ}\text{C} \sim 28^{\circ}\text{C}$ and relative humidity less than 80%.The presentation for accuracy is: $\pm (a\%$ reading digits + b digits)

AC Voltage Accuracy

Range	Resolution	Accuracy		
		40Hz~60Hz	60Hz—5KHz	5KHz—10KHz
200mV	0.01mV	$\pm(0.5\% +30)$	$\pm(1.5\% +30)$	$\pm(2.5\% +30)$
2V	0.1mV	$\pm(0.5\% +30)$	$\pm(1.5\% +30)$	$\pm(2.5\% +30)$
20V	1mV	$\pm(0.5\% +30)$	$\pm(1.5\% +30)$	$\pm(2.5\% +30)$
200V	10mV	$\pm(0.5\% +30)$	$\pm(1.5\% +30)$	$\pm(2.5\% +30)$
750V	0.1V	$\pm(0.5\% +30)$	$\pm(1.5\% +30)$ (1KHz)	Unspecified

Note: Above accuracies can be guaranteed within 20% - 100% of the full range .

DC Voltage Accuracy

Range	Resolution	Accuracy
200mV	0.01mV	$\pm(0.05\% +6)$
2V	0.1mV	$\pm(0.05\% +6)$
20V	1mV	$\pm(0.05\% +6)$
200V	10mV	$\pm(0.05\% +6)$
1000V	0.1V	$\pm(0.05\% +6)$

Note: Above accuracies can be guaranteed within the full range.

AC Current Accuracy

Range	Resolution	Accuracy		
		40Hz~60Hz	60Hz~1KHz	1KHz~5KHz
200 μ A	0.01 μ A	$\pm(0.8\% +30)$	$\pm(1.0\% +30)$	$\pm(1.2\% +30)$
2000 μ A	0.1 μ A	$\pm(0.8\% +30)$	$\pm(1.0\% +30)$	$\pm(1.2\% +30)$
20mA	1 μ A	$\pm(0.8\% +30)$	$\pm(1.0\% +30)$	$\pm(1.2\% +30)$
200mA	10 μ A	$\pm(0.8\% +30)$	$\pm(1.0\% +30)$	$\pm(1.2\% +30)$
10A	1mA	$\pm(1.0\% +30)$	$\pm(1.5\% +30)$	$\pm(2\% +30)$

Note: Above accuracies can be guaranteed within 20% - 90% of the full range.

DC Current Accuracy

Range	Resolution	Accuracy
200 μ A	0.01 μ A	$\pm(0.15\% +15)$
2000 μ A	0.1 μ A	$\pm(0.15\% +15)$
20mA	1 μ A	$\pm(0.15\% +15)$
200mA	10 μ A	$\pm(0.15\% +15)$
10A	1mA	$\pm(0.5\% +15)$

Note: Above accuracies can be guaranteed within the full range.

Resistance Accuracy

Range	Accuracy
200 Ω	$\pm(0.1\% +10)$

Range and Accuracy

Range	Accuracy
2K Ω	$\pm(0.1\% +10)$
20K Ω	$\pm(0.1\% +5)$
200K Ω	$\pm(0.1\% +5)$
2M Ω	$\pm(0.1\% +10)$
20M Ω	$\pm(0.5\% +10)$
200M Ω	$\pm(2\% +10)$

Notes: 1. Above accuracies can be guaranteed within the full range.

2. Accuracy for diode and continuity are unspecified. In Continuity Test Mode, the bluzzer will beeper if the measure value lower than 20 Ω , may or not beep if the measure value between 20 Ω and 50 Ω . not beep when the measure value higher than 50 Ω

Capacitance Accuracy

Range	Resolution	Accuracy
20nF	0.01nF	$\pm(1.2\% +30)$
200nF	0.1nF	$\pm(1.2\% +30)$
2 μ F	1nF	$\pm(1.2\% +30)$
20 μ F	10nF	$\pm(1.2\% +30)$
200 μ F	0.1 μ F	$\pm(2.2\% +30)$
2000 μ F	1 μ F	$\pm(2.2\% +30)$
20mF	10 μ F	$\pm(2.2\% +30)$
200mF	100 μ F	Unspecified

Notes:

- Above accuracies for film capacitor or better can be guaranteed within the full range.

- Above specification from 20nF to 2uF ranges are specified under REL mode. The reading is calibrated to zero by relative function when input is floating.

Logic Frequency:

Frequency Range	Signal	Accuracy
20Hz~220MHz	Vpp 3V square wave	±(0.06% +10)

Linear Frequency:

Input Range	AC Sensitivity (TRMS sine wave)	
	5Hz~10KHz	10KHz~100KHz
200mV	5mV	10mV
2V	50mV	100mV
20V	500mV	1000mV
200V	5V	10V
750V	50V(Note 1)	Unspecified
200 μ A	5 μ A(Note 1)	Unspecified
2000 μ A	50 μ A(Note 1)	Unspecified
20mA	50 μ A(Note 1)	Unspecified
200mA	5mA(Note 1)	Unspecified
10A	500mA(Note 1)	Unspecified

Note 1: Frequency response 50Hz~10KHz.

Duty

Duty Scale	Accuracy
5%~95%	$\pm 10\%$

CIAMP

Range	Resolution	Accuracy
DC 220A	0.01A	$\pm (0.1\%+10)$
DC 2200A	0.1A	$\pm (0.1\%+10)$
AC 220A (50~60Hz)	0.01A	$\pm (1\%+30)$
AC 2200A(50~60Hz)	0.1A	$\pm (1\%+30)$

Temperature

Range	Resolution	Accuracy
-30°C~1300°C	1°C	$\pm (1\%+2)$

Note: Accuracies apply following 90 minutes settling time after a change in the ambient temperature of the instrument.

Chapter 5 Maintenance

Introduction

Repairs or servicing not covered in this manual should only be performed by qualified personnel.

Replacing the Fuse

Use the following procedure to examine or replace the multimeter of fuses:

- Turn the power switch to off, and remove the power cable from live power source.
- Disconnect test leads from any live source, turn the rotary switch to off, and remove the test leads from the input terminals.
- Open the tools cover on the top cover, and open the fuse cover in the tool case.
- Remove the blown fuse, replace with fuse of the same size and rating. Make sure the new fuse is centered in the fuse holder.
- Replace the blown fuse with same ratings. The A input terminal is protected by a F10A/250V fast blow ceramic fuse, $\Phi 6 \times 32\text{mm}$. The mA input terminal is protected by a F300mA/250V fast blow fuse, $\Phi 5 \times 20\text{mm}$.
- Fuse rarely need replacement and blow almost always as a result of the operator's error.
- Never use the bench multimeter unless the fuse cover is in place and fastened fully.

Note: To avoid electrical shock, disconnect the test leads and any input signals before replacing the fuses. Replace only with same type of fuses. The A input terminal is protected by a F10A/250V fast blow ceramic fuse. The mA input terminal is protected by a F300mA/250V fast blow fuse.

Replacing the Power Fuse

Use the following procedure to examine or replace the power fuses:

1. Turn the power switch to off, and remove the power cable from live power source.
2. Disconnect test leads from any live source, turn the rotary switch to off, and remove the test leads from the input terminals.
3. Replace the power fuse from the supply power inlet with fuse. Replace the blown fuse with same ratings.
4. The power fuse: 100mA / 250V, Fast, $\Phi 5 \times 20$ mm.

Note: To avoid electrical shock, disconnect power cable from live power source , and remove the test leads and any input signals before replacing the power fuses. Replace only with same type of fuses.

Replacing the Battery

When the multimeter displays the “” mark, the battery must be replaced to maintain proper operation. Use the following procedure to replace the battery:

- Disconnect test leads from any live source, turn the rotary switch to off, and remove the test leads from the input terminals.
- Remove screws on the battery cover and open the case.
- Remove the exhausted battery and replace with a new equivalent 9 voltge battery.
- Two types of batteries are used in the bench multimeter: one of is a NEDA 1604 6F22 006P type one piece or equivalent 9 voltge battery; other of is IEC LR6 AM3 AA 1.5V $\times 6$ pieces.
- Never use the bench multimeter unless the battery cover is in place and fastened fully.

Note: To avoid electrical shock, disconnect power leads from live power sourceand remove the test leads and any input signals before replacing the battery. Replace only with same type of battery.

Chapter 6 Accessories

Item	Quantity
Manual	1
Test Leads	2
Power Cord	1
RS232C Cable(R3415 Cable optional)	1
K Type Thermocouple	1
Multi-Function Socket	1
CD-ROM	1

HYS005756