

Total solder points: 71

Difficulty level: *beginner* 1  2  3  4  5  *advanced*

## TEMPERATURE SENSOR

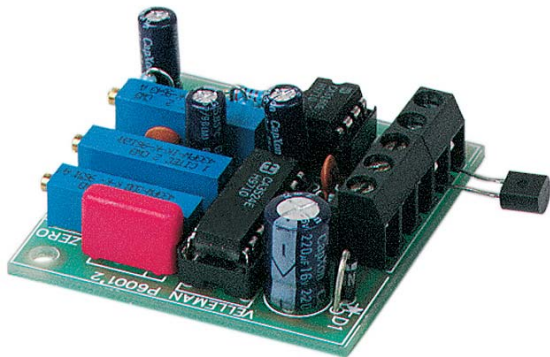

# *K6001*

For use with our K6000 or  
K6002 kits.



This kit has been developed especially to be combined with our K6000 or K6002 in order to create a temperature regulating and temperature control system. Combined with the K6000 kit, a completely programmable thermostat can be assembled. The use of a separate sensor offers the advantage of making the distance between the controller and the sensor irrelevant.

### Specifications:

- Temperature range of the transmitter :  $-40^{\circ}\text{C}$  to  $150^{\circ}\text{C}$ .
- Pulse width modulation :  $200\mu\text{s} / ^{\circ}\text{C}$ .
- Generated pulse width :
  - at  $-40^{\circ}\text{C}$  :  $2\text{ms}$  (+/-  $500\mu\text{s}$  adjustable)
  - at  $150^{\circ}\text{C}$  :  $40\text{ms}$  (+/-  $2500\mu\text{s}$  adjustable)
- Linearity from  $-10^{\circ}\text{C}$  to  $50^{\circ}\text{C}$  : better than 0,5%.
- Full scale : better than 2%.
- Tested up to 50m (distance between sensor and controller)
- Output : 15mA current loop
- Supply voltage : 12VDC (+/- 2V) / 20mA Max.
- PCB dimensions: 45 x 47mm (1.8" x 1.9")

### 1. Assembly (Skipping this can lead to troubles !)

Ok, so we have your attention. These hints will help you to make this project successful. Read them carefully.

#### 1.1 Make sure you have the right tools:

- A good quality soldering iron (25-40W) with a small tip.
- Wipe it often on a wet sponge or cloth, to keep it clean; then apply solder to the tip, to give it a wet look. This is called 'thinning' and will protect the tip, and enables you to make good connections. When solder rolls off the tip, it needs cleaning.
- Thin raisin-core solder. Do not use any flux or grease.
- A diagonal cutter to trim excess wires. To avoid injury when cutting excess leads, hold the lead so they cannot fly towards the eyes.
- Needle nose pliers, for bending leads, or to hold components in place.
- Small blade and Phillips screwdrivers. A basic range is fine.

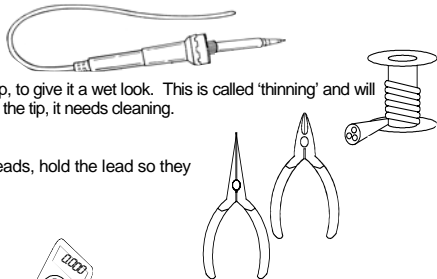

**For some projects, a basic multi-meter is required, or might be handy**



#### 1.2 Assembly Hints :

- ⇒ Make sure the skill level matches your experience, to avoid disappointments.
  - ⇒ Follow the instructions carefully. Read and understand the entire step before you perform each operation.
  - ⇒ Perform the assembly in the correct order as stated in this manual
  - ⇒ Position all parts on the PCB (Printed Circuit Board) as shown on the drawings.
  - ⇒ Values on the circuit diagram are subject to changes.
  - ⇒ Values in this assembly guide are correct\*
  - ⇒ Use the check-boxes to mark your progress.
  - ⇒ Please read the included information on safety and customer service
- \* Typographical inaccuracies excluded. Always look for possible last minute manual updates, indicated as 'NOTE' on a separate leaflet.

### 1.3 Soldering Hints :

1- Mount the component against the PCB surface and carefully solder the leads

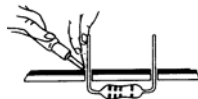

2- Make sure the solder joints are cone-shaped and shiny

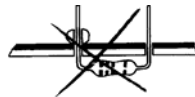

3- Trim excess leads as close as possible to the solder joint



**AXIAL COMPONENTS ARE TAPED IN THE CORRECT MOUNTING SEQUENCE !**

REMOVE THEM FROM THE TAPE ONE AT A TIME !

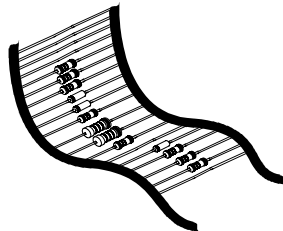

 You will find the colour code for the resistances and the LEDs in the HALG (general manual) and on our website: <http://www.velleman.be/common/service.aspx>

## 1. Metal film resistors

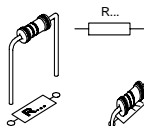

- R1 : 240K (2-4-0-3-1)
- R3 : 3K (3-0-0-1-1)
- R4 : 4K7 (4-7-0-1-1)
- R5 : 10K (1-0-0-2-1)
- R6 : 1K8 (1-8-0-1-1)

## 2. Capacitors.

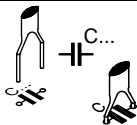

- C1 : 470pF (471)
- C2 : 470pF (471)

## 3. IC socket. Watch the position of the notch!

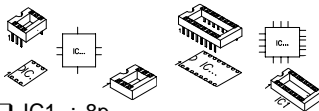

- IC1 : 8p
- IC2 : 16p

## 4. Diode. Watch the polarity !

- D1 : 1N4007

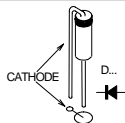

## 5. Metal film resistors

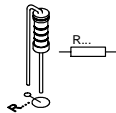

- R2 : 15K (1-5-0-2-1)
- R7 : 1K8 (1-8-0-1-1)

⚠ **Attention** : because one of the connections of both R2 and R7 is a measuring point, it is advisable to take care that the body of the resistors is on the largest circle of the pcb overprint.

## 6. Resistor

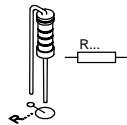

- R8 : 560 (5-6-1-B)

## 7. Multiturn trimmers

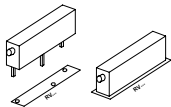

- RV1 : 1K (OFFSET)
- RV2 : 200K (ZERO)
- RV3 : 5K (GAIN)

**Offset** : Zero-setting of the sensor.  
**Zero** : Calibration at zero degrees.  
**Gain** : Maximum temperature calibration.

## 8. Capacitor.

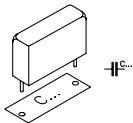

- C3 : 470nF ( $\mu 47$ )

## 9. Terminal block connectors

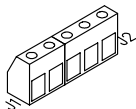

- J1 : 2p + 3p

## 10. Electrolytic Capacitors. Watch the polarity !

- C4 : 10 $\mu$ F
- C5 : 10 $\mu$ F
- C6 : 10 $\mu$ F
- C7 : 220 $\mu$ F

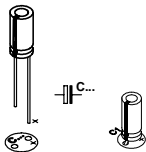

## 11. IC's. Watch the position of the notch!

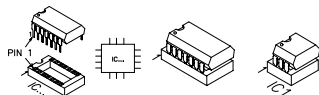

- IC1 : TLV271 or eq.
- IC2 : 3524 or eq.

## 12. Preparing the sensor

- ❑ Cut two 5cm pieces of the supplied copper wire (fig. 1.1). Using a knife, remove the varnish of both pieces of wire over some 3mm from the ends and tin the ends (fig. 1.1)

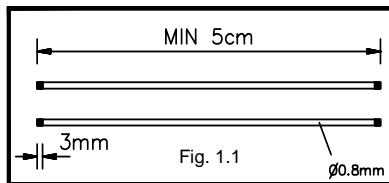

- ❑ Cut the connections of the KTY11, KTY81-22 sensor or eq. at 3mm (fig. 1.2)
- ❑ Solder both copper wires to the sensor (fig. 1.3)

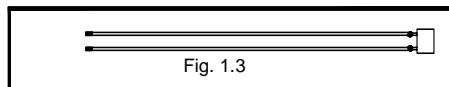
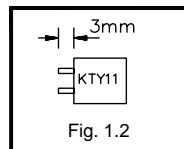



- ❑ Cut off a piece of shrinking tube with a length equal to 5cm
- ❑ Slide the shrinking tube over the copper wires and OVER the sensor (fig. 1.4)

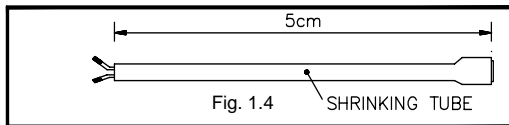

- ❑ Heat the shrinking tube using a hair dryer or, better still, using a paint stripper.
- ❑ Connect the transmitter (type KTY11, KTY81-22 or equivalent) with the points SENSOR of the pcb, using a piece of screened wire (+/- 50cm). The polarity is of no importance.

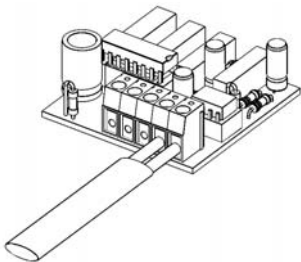

### 13. Adjustment & use



**IMPORTANT** : First have the circuit "warmed up" for about 10 minutes before starting adjusting!

- Connect the transmitter (type KTY11, KTY81-22 or equivalent) with the points SENSOR of the pcb, using a piece of screened wire (+/- 50cm). The polarity is of no importance.
- Connect a DIGITAL measuring apparatus between the two connection wires of R2 and R7.
- Connect 12VDC to the points +VS and -VS.

**REMARK** : Be careful to not touch the circuit with your hands while adjusting it, because this could cause noise at its output, and consequently a very unstable read out.

- Fill a glass with ice cubes and let them melt a little until you get ice-water.
- Plunge the transmitter into the melting ice-water (0°C). Take care that the connection wires of the transmitter do not touch the water.
- Adjust the OFFSET trimming potentiometer RV1, so that the meter indicates 0V (possibly select a more sensitive measuring range) and wait until the indication becomes stable.



**THIS ADJUSTMENT IS VERY IMPORTANT, SO CARRY IT OUT VERY CAREFULLY!**

**Further adjustment with the controllers such as K6000, K6002 a. o. :**

- Connect the output of the sensor (OUT + and -) with the points IN (+ and -) of the controller (this can be sensor 1 to 4 in the case of K6000)
- Plunge the transmitter into the melting ice again and adjust the ZERO trimming potentiometer RV2 so that the indication for this sensor indicates 0°C, and wait until the indication remains stable.

When using the controller as a room thermostat, you better adjust the maximum indication against body temperature, using the GAIN trimming potentiometer. It is advisable to verify the temperature at the place of the sensor with a clinical thermometer.

**REMARK :** If the sensor is intended to be used for measuring liquid temperatures, it has to be insulated by enclosing it with silicone or glue.

In case you want higher accuracy above 40°C, then calibrate the sensor in a known source of heat e.g. boiling water (100°C).

 **With temperatures under 0°C and above 70°C it is advisable to not install the electronic circuitry (pcb with components) near the transmitter.**

 **The specifications are indicative and can differ from one transmitter to another.**



**REPEAT THE FULL ADJUSTMENT PROCEDURE AT LEAST ONE MORE TIME!**

## 14. Mounting and connecting

The pcb is made in such a way that it easily can be built into a standard wall box, on a blind cover plate.

- Make a hole in the cover plate to pass the sensor (KTY11, KTY81-22 or eq.) through. The sensor shouldn't touch the cover plate.
- For making the electrical connections, use ordinary wiring or telephone wire of 0.5mm.
- For feeding the sensor use an un stabilised 12VDC power supply, which is able to supply at least 20mA (you easily can make it yourself, see fig. 1.5). With the K6000 controller, a power supply on the controller itself can be used. This power supply is able to feed up to four sensors.

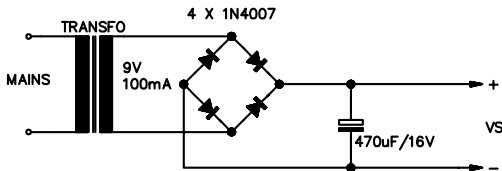
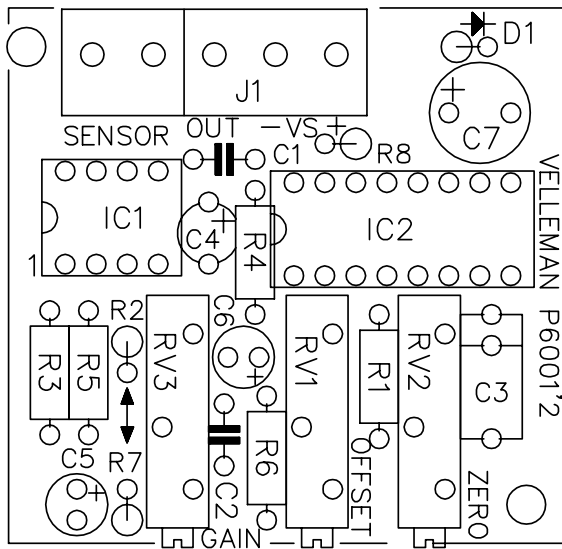
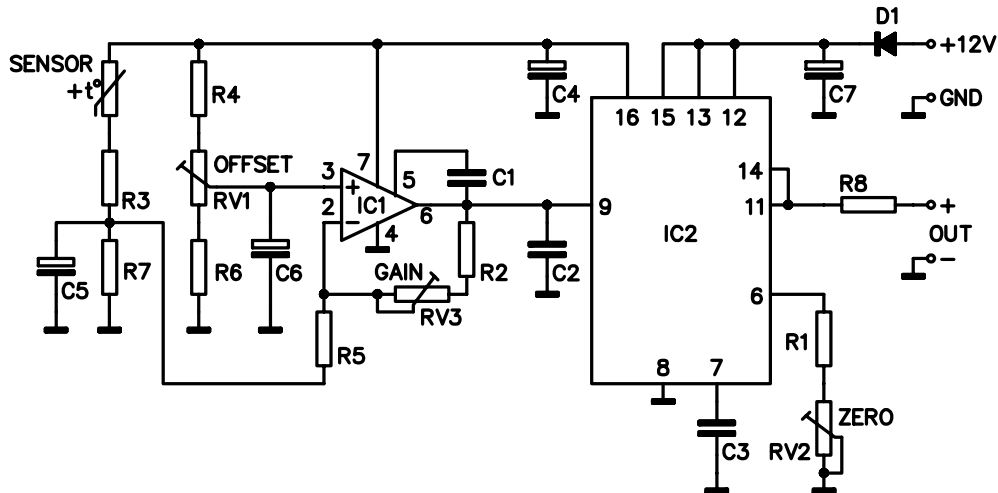

Fig. 1.5

15. PCB layout.



## 16. Diagram







Modifications and typographical errors reserved

© Velleman Components nv.

H6001IP - 2004 - ED2 (rev 2)

