

DIY Kit 113. DUAL STEPPER MOTOR CONTROLLER

INTRODUCTION

This kit enables users to control two unipolar stepper motors via a parallel/printer port of a PC. Four digital inputs are also included. These can be used for monitoring external switches & inputs. The kit itself does not require any power source. The stepper motors require power.

The kit is designed to fit into an extended D-shell plastic case. This is also called an RS232 plastic case. A DOS based program written specifically to drive stepper motors is included on disk, complete with C source code.

The kit is constructed on a double-sided, through-hole-plated printed circuit board (PCB). Protel Autotrax & Schematic were used to design the board.

ASSEMBLY INSTRUCTIONS

Start by fitting the two D25 connectors to the PCB. The **male** connector fits in position **X1**. This is the connector which fits into the parallel port of the PC. The **female** connector fits in position **X2**. Attach these connectors first for two reasons: access to the pins is easier when none of the other components are present, & two, you can see immediately that the PCB will fit in the RS232 case.

Insert the PCB between the two rows of pins on each connector. Use a flat-bladed screwdriver to spread the pins apart slightly if required. Make sure the connector pins are centered on the PCB pads and that the connectors are the right way around. Push the PCB in until the edge is touching the plastic housing of each connector. Check that it fits easily into the case.

Next solder the diodes and resistors into place. Follow the component overlay on the PCB for placement of components.

The kit has been supplied with eight 3.3K resistors instead of a 3.3K 16-pin resistor network. Bend the legs of these resistors close to the resistor body and insert them between the two rows of pins of "RP1". The first resistor connects between pins 1 and 16, the second between pins 2 and 15, etc. It does not matter if the resistors sit up slightly (up to 5mm) above the PCB.

Now fit the transistors. Note that the transistors have a flat side and a slightly rounded side. Make sure that it is inserted correctly as outlined on the component overlay.

The tops of transistors should not be more than 5mm above the surface of the PCB if the case is to fit easily. To do this one trick is to push them over about 20° so they are lower. Bend out the center leg with needle nosed pliers almost at the body of the transistor in order to get them fitting lower on the board. Another approach is to drill out a slot in the case so they can poke through. This is to be recommended if the steppers you will drive are over about 2 amps. (See below for more discussion on this.)

CIRCUIT DESCRIPTION

The circuit consists of eight high-gain NPN transistors (Q1-8) that are driven via the eight data outputs of the PC printer port. The transistor outputs are open collector, which means that the load is connected between the

transistor collector pin and a positive voltage source. Protection diodes (D1-8) are provided so that the back EMF generated when driving inductive loads, such as stepper motors, will not damage the transistors.

Four high voltage inputs (up to 15V) are also included. Any input voltage above 5.1 volts (nominal) will be clamped by the 5.1V zener diodes (Z1-4). Resistors, R1-4, provide current limit protection for the zeners.

The kit is really a digital I/O device with 8 active-low outputs and 4 protected inputs. The outputs can be used to switch relays, LEDs, lamps or any other "on-off" device. It is the software provided with the kit that makes it a stepper motor controller.

STEPPER MOTORS

Stepper motors are a special type of motor. Instead of rotating smoothly, they move incrementally - in steps. Each step is a fixed angular displacement of the motor's shaft. For example, if the step increment is 3.6°, then 100 steps are required for a complete 360° rotation of the shaft.

There are two types of stepper motors:

1. *Bipolar motors*. These have two coils and are controlled by changing the direction of the current flow through the coils in the proper sequence. These motors have only four wires and cannot be connected to this kit. They are declining in availability.
2. *Unipolar motors*. These have two center-tapped coils which are treated as four coils. These motors can have five, six or eight wires. Five-wire motors have the two center-taps commoned internally and brought out as one wire (Fig 1). Six-wire motors bring out each center-tap separately. The two center-taps need to be commoned externally (Fig 2). Eight-wire motors bring out both ends of each coil. The four "center-taps" are joined externally to form one wire. In each case the center-tap(s) are connected to a positive motor power supply.

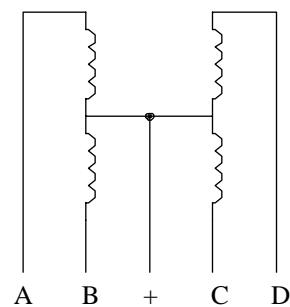
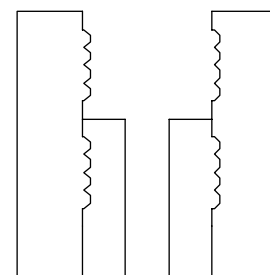

Fig 1. Five-wire stepper motor



DIY Kit 113. DUAL STEPPER MOTOR CONTROLLER

A B + + C D
Fig 2. Six-wire stepper motor

6	0	0	1	0
7	0	0	1	1
8	0	0	0	1

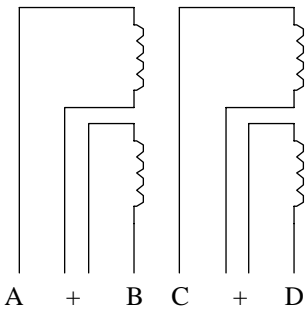

Fig 3. Eight-wire stepper motor

Unipolar stepper motor sequencing

Stepper motors rotate by energizing each coil or coils in sequence. There are three common sequences used to drive stepper motors, given in the following tables. In each case, the steps are repeated when the end of the table is reached. The direction in which the motor steps depends on which way the sequence is applied.

1. *Two-Phase sequence.* This method energizes two coils at a time which provides the greatest amount of motor torque. It is the most common method used.

Step	A	B	C	D
1	1	1	0	0
2	0	1	1	0
3	0	0	1	1
4	1	0	0	1

2. *Wave sequence.* This method is also known as wave drive and only energizes one coil at a time. On some motors, this gives a smoother motion than the two-phase sequence. However this also means that the torque of the motor is also reduced.

Step	A	B	C	D
1	1	0	0	0
2	0	1	0	0
3	0	0	1	0
4	0	0	0	1

3. *Half-step sequence.* This sequence interleaves the normal and wave sequences. This causes the motor to step at half its normal angle. Therefore a 3.6° (100 step) motor now steps at 1.8° and requires 200 steps for a complete rotation. This sequence also suffers from reduced motor torque because sometimes only one coil is being used to step the motor.

Step	A	B	C	D
1	1	0	0	1
2	1	0	0	0
3	1	1	0	0
4	0	1	0	0
5	0	1	1	0

Step rates

Stepper motors are mechanical devices and so the rate at which step pulses are applied is important. The motor must complete its previous step before the next voltage sequence is applied. If the step rate is too fast, the motor may:-

- not move at all
- vibrate instead of step
- rotate erratically - two steps one-way, then 2 back
- rotate in the wrong direction

SIZE OF STEPPER MOTORS

The kit has been tested with a variety of stepper motors. However, whilst the output transistors have a continuous collector **current rating of 3 amperes**, they do get quite hot when driving large stepper motors. The problem is even worse when the motor is stationary (not stepping). In this case one or two coils are permanently energized, causing large currents to flow through the 'ON' transistors.

We have used stepper motors from old 5.25" disk drives and had them spinning for hours at a time. Total current consumption is less than 450mA using the two-phase drive sequence. Current consumption rises to 660mA with both motors stopped. The transistors barely get warm.

Generally speaking, any stepper motor that draws no more than **one ampere per motor can be connected**. You may need to experiment to determine if the kit can handle larger motors up to the maximum 3 amp rating of the transistors. If the transistors heat too much then a ventilation slot may be required in the case above the transistors to help cool them. If it is known that a slot is required then the transistors could be mounted through the slot.

MOTOR SPEED AND THE BALLAST RESISTOR

Stepper motors require a ballast resistor for maximum speed and quicker response. Most applications will not need them but others may. Stepper motor coils are inductors which must be charged before the motor can move. The charge curve for an inductor is a log curve when a voltage is applied and a straight line when a constant current is applied. The maximum speed of a stepper motor is determined partly by how long it takes the coil to charge. Constant current power supplies are expensive to build. A constant current source can be approximated by using a ballast resistor in series with a higher voltage than the motor is rated for.

Ballast resistors are also used to match a higher voltage power supply to a stepper motor. The value of the resistor is calculated using the equation:

$$\frac{(V_{\text{supply}} - V_{\text{motor}})}{\text{current drawn by motor in use}}$$

A typical value of a ballast resistor is 10R, 5W.

DIY Kit 113. DUAL STEPPER MOTOR CONTROLLER

CONNECTING A STEPPER MOTOR

Each motor is connected to the kit via X2 using a male D25 connector. We have supplied this connector and plastic case. You have to supply the cable and stepper motors. Use the following chart for pin assignments.

X2 pin	Motor	Coil
1	X	A
2	X	B
3	X	C
4	X	D
14, 15, 16, 17	X	CENTER-TAP
6	Y	A
7	Y	B
8	Y	C
9	Y	D
18, 19, 20, 21	Y	CENTER-TAP
10, 11, 12, 13	INPUTS	
5	NOT CONNECTED	
22, 23, 24, 25	POWER SUPPLY GROUND	

Table 1

Note that pins 14-17 and 18-21 also connect to the positive output of the motor power supply (via a ballast resistor if necessary). If the same power supply is used for both motors then common the two supply leads at the power supply end (see Fig 4).

It is possible to use a different power supply for each motor. Just connect the positive output of each supply to pins 14-17 or 18-21 as required. Don't forget to common the negative of each supply together and connect to one of the pins 22-25.

WHICH WIRE IS WHAT?

Stepper motors do not usually have each wire labeled. Also most are obtained by the hobbyist second-hand so there is no information which comes with them. It is up to the user to figure it out. The only way to do this is by trial and error. You will need to use a resistance meter.

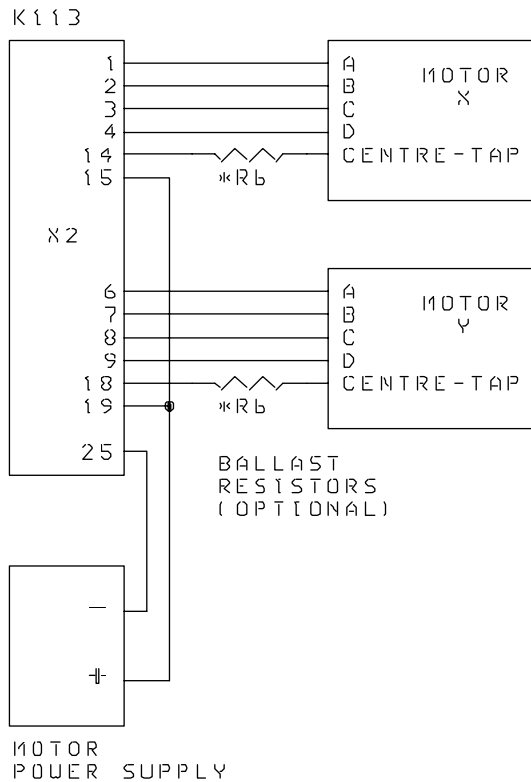

Fig 4

Five-wire motor (Fig 1)

Measuring the resistance between the center-tap and any of the coil ends gives a value which is approximately half that when measuring across the coil ends.

Pick one wire and measure the resistance between it and each of the other wires. When you get the same reading all the time then you have found the center-tap.

Six-wire motor (Fig 2)

The first thing to do here is to separate the six wires into two groups of three (two center-tapped coils). This is quickly done by measuring the resistance between each wire. When there is no reading (open circuit) then the two wires belong to different groups. Fortunately many manufacturers already group the six wires into two groups of 3 as they leave the motor. So you can immediately move to the next step.

Once separated it is simply a matter of measuring the resistance between each of the wires in that group to find the center-tap wire. Join the two center-tap wires together.

Eight-wire motors (Fig 3)

There should be four groups of two wires (four coils). Measure the resistance between each wire and separate into groups. Pick a wire from each group and join them all together. This is the center-tap.

Now that the motor wires have been identified, label each one as 'A, B, C, D and CT (center-tap)'. This will help when connecting to the kit.

PUTTING IT ALL TOGETHER

Using Table 1 and Figure 4, connect each motor to the kit. Solder each wire to the correct pin on a male D25

DIY Kit 113. DUAL STEPPER MOTOR CONTROLLER

connector and then plug it onto connector X2 on the kit. Don't forget to connect the power supply wires (positive and negative).

Plug the kit into the PC parallel port. If you have a 25-way straight-through cable then use it connect the kit to the PC port. This will make it easier during the testing stage.

Turn on the power supply and run the software. Is the software using the same parallel port that you are connected to?

At the command prompt, type 'RATE X 1000' (upper or lower case). This slows down the step rate to 1 per second. Now type 'SPIN X'. Motor X should start rotating, one step every second. If not then the 'ABCD' wires may need to be swapped around.

Unfortunately, this is one of those "trial and error" situations. If the motor had the two groups of wires identified then there are 4 possible combinations: AB & CD, AB & DC, BA & CD and BA & DC.

If the groups were not identified then there are 6 combinations: leave A in place - this does not need to be changed. Then move through BCD, BDC, CBD, CDB, DBC & DCB.

REMEMBER: Disconnect from PC and power supply when swapping wires around.

If you have done the above & the motor does not work correctly the most likely causes are that the wiring is incorrect somewhere or the soldering is a problem.

As a final recourse check the output voltages going to the motor. This is best done by an LED & 1K resistor attached to each motor input & positive of the power supply (Fig 5). The flashing LED pattern shows when each coil is energized. No LED's on means no power is going to the motor. Any LED pattern should tell you where the connections need to go. Go to WAVE mode. Then only one coil should be turned on at a time.

SOFTWARE

The software supplied (DUALSTEP.EXE) enables two unipolar stepper motors to be controlled with this kit. The program is **DOS-based** and was written using Borland Turbo C 3.0. The "C" source code is also supplied on disk. Look on our website <http://kitsrus.com> for the latest version of the software.

The software has two modes of operation.

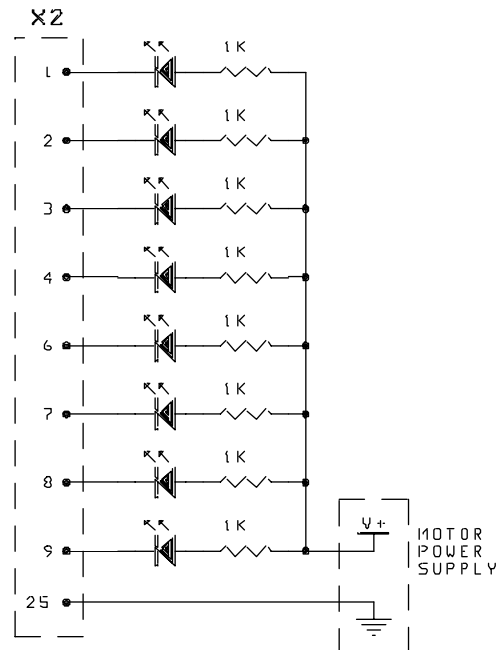

Fig 5. Test circuit

1. Standalone mode

To run the program, type:

```
DUALSTEP </port>
```

where port = LPT port number (1, 2, 3 or 4). The port number is optional and defaults to LPT1 if not specified.

eg. 'DUALSTEP /2' uses LPT2 as the control port.

2. Batch mode

In this mode, the program processes commands contained in a text file. Standard DOS I/O redirection is used to input the commands from the file.

For example.

To process the file "CMDFILE", use the following command line:-

```
DUALSTEP <CMDFILE.
```

This uses the DOS input redirection operator '<' to read input from "CMDFILE" rather than the keyboard.

Alternatively, you could use:-

```
TYPE CMDFILE | DUALSTEP
```

This uses the DOS pipe operator '|' to send the output of the first command (TYPE) to the input of the second command (DUALSTEP).

Command Summary

The following is a description of the commands available to control the stepper motors. Each stepper motor can be individually addressed as X or 1, Y or 2. Both motors may be addressed as B. Commands and parameters can be in upper or lower case. Parameters in <> are optional.

DIY Kit 113. DUAL STEPPER MOTOR CONTROLLER

Each command takes effect immediately even if the previous command has not finished executing. For example, a STEP command can be issued and while it is executing, the RATE command can be given to alter the step rate. The WAIT command has been included to prevent this - necessary when executing a program from a text file.

- HSTEP** motor.....Set motor to use half-step drive sequence.
- 2PHASE** motor.....Set motor to use two-phase drive sequence. This is the default drive sequence.
- WAVE** motor.....Set motor to wave drive sequence
- RATE** motor val1 <val2> ...Set the delay rate between steps (in milliseconds). Range from 1 to 50,000.
- DIR** motor <CW, CCW>Set the direction of rotation.
CW = clockwise
CCW = counter-clockwise.
If no direction is given then it is reversed.
- STEP** motor val1 <val2> ...Step motor by val1 steps. If motor is both then val1 refers to 'X' and val2 refers to 'Y'.
- WAIT** motorWait for the previous motor command to finish before executing the next command for that motor.
- SPIN** motor.....Continuously step motor. Not affected by 'WAIT'.
- STOP** <motor>.....Immediately stop the current command for motor. If no motor is specified then stops both. Ignores 'WAIT'.
- MANUAL**Manually step motors.
Another menu appears.
- LOPTIL** input(n) HIGH,LOW
where n=1, 2, 3 or 4.Wait for the specified input to go high or low before continuing.
- DELAY** millisecondsWaits the specified delay time before continuing. Range = 1 to 50,000.
- ECHO** ON or OFF.....If ON (default) then all commands are echoed to the output.
- PRINT** message.....to output
- VER**.....Print version number
- END**.....Wait for all motor commands to finish then quit
- QUIT**.....Quit program immediately
- HELP**Display above summary

Semiconductors

1N4004.....	D1-8.....	8
1N751A	Z1-4.....	4
5.1V 400mW zeners		
ZTX1053A	Q1-8.....	8
NPN High Gain Transistors		

Miscellaneous

D25 connector, male.....	X1	1
solder type		
D25 connector, female.....	X2	1
solder type		
Plastic "D" shell extended covers		
Screws for this case.....		
K113 PCB		
Floppy disk.....		

To connect to stepper motors

D25 connector, male, solder type	1
Plastic case for this connector	1
Ribbon cable	2ft

You must supply the stepper motors.

REFERENCES

The Internet is the place to get references and a lot of technical support. See the Links section of our web site for a list of sites which discuss stepper motors.

<http://kitsrus.com>

PARTS LIST - KIT 113

Resistors (0.25W, 5%)

220.....	R1-4	4
3K3.....	RP1:A-H	8

