

DIY Kit 124 - POSITIVE ADJUSTABLE POWER SUPPLY MODULE

INTRODUCTION

This kit is a compact, easy to build and use positive variable power supply module. It is ideal for powering any application requiring a DC supply at current levels up to 1.5A

FEATURES:

- Output reverse polarity and back-voltage protection
- LED power on indication
- On board heatsink for IC regulator
- Variable output voltage
- AC or DC input voltage
- Low noise (uses linear regulator)
- Screw terminals for input, output and LED indicator
- Compact dimensions (84 x 37 mm)

This kit can be combined with Kit 125 to create a dual-rail supply.

The kit is constructed on a single-sided printed circuit board (PCB). Protel Autotrax & Schematic were used to design the board.

ASSEMBLY INSTRUCTIONS

Follow the overlay on the PCB when inserting components. Start with the lowest height components first. Leave the 2200uF capacitor, heatsink and regulator IC until last. Make sure that the polarised components, diodes and electrolytic capacitors, are inserted the correct way round.

Note: Take care when bending the diode leads. Use a pair of long nose pliers to hold the lead close to the body to avoid stressing the diode itself. Make sure that the diode leads are bent accurately to fit into the PCB.

Lightly secure the regulator IC to the heatsink using the screw and nut provided. Use some heatsink compound if available. Fit the whole assembly to the PCB and solder into position. Tighten the screw and nut. Now fit the 2200uF capacitor.

CIRCUIT DESCRIPTION

Diodes D1-4 form a bridge rectifier which converts the AC input voltage into a DC level. They also allow a DC input voltage to be connected either way around. Capacitor C1 smooths the DC output of the bridge whilst C2 provides high frequency decoupling. The LM317T is an adjustable regulator IC providing the desired output voltage. Diode D5 is reversed biased during normal operation and is used to protect the regulator if the output is connected to a voltage of the same polarity (eg battery). Diode D6 protects the regulator if a reverse polarity voltage is connected to the output.

The regulator develops a nominal 1.25V reference voltage between the output and adjust terminals. This constant voltage is applied across R1, causing a constant current to flow. This constant current flows through trimpot VR1. By varying VR1, the voltage across it will vary and hence the output voltage can be set.

The output voltage is calculated by:

$$V_{OUT} = 1.25(1 + \frac{VR1}{R1})$$

Capacitor C3 improves the ripple rejection of the regulator while capacitorS C4 and C5 provide high and low frequency decoupling respectively.

The LED indicates that power is present at the output. The current through the LED should be between 5 and 20mA and is set by resistor R2. The value of R2 varies depending on the required output voltage and is calculated by

$$R_2 = \frac{V_{OUT} - V_{LED}}{10 \times 10^{-3}} \quad \text{where } V_{LED} \approx 2V$$

INPUT CONFIGURATION

There are a number of different input configurations that can be used with this kit. The configuration chosen will depend on the available voltage source. Wherever possible, keep the input voltage as low as possible to achieve the required output. This minimises the heat dissipation on the regulator.

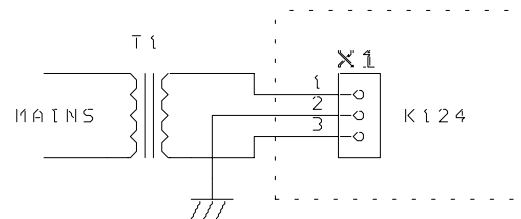

AC Transformer - single output

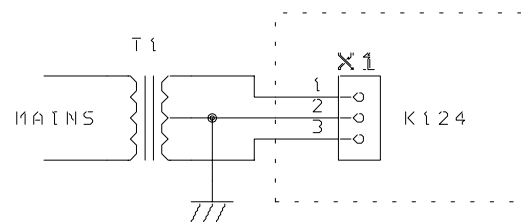

AC Transformer - centre-tapped output

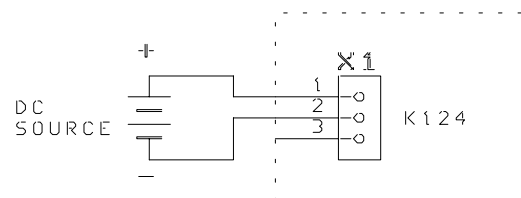

DC input source

DIY Kit 124 - POSITIVE ADJUSTABLE POWER SUPPLY MODULE

DUAL POWER SUPPLIES

Dual power supplies are possible by combining Kit 124 with Kit 125. In this case, a transformer with either two separate output windings or a centre-tapped output are required. The following diagrams show the input configuration using these types of transformers.

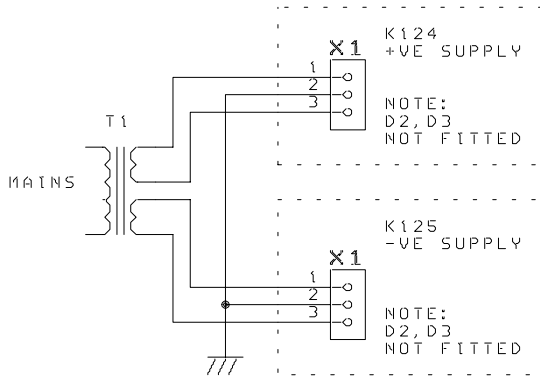

Using transformer with two output windings

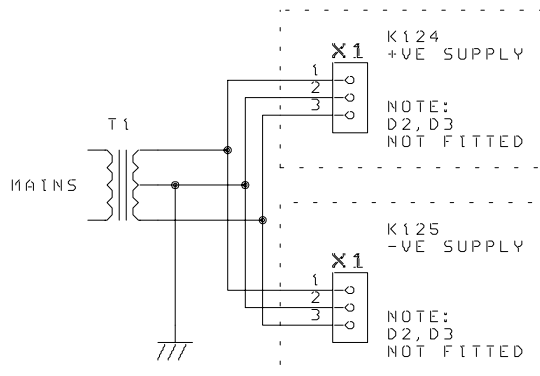

Using transformer with centre-tapped output winding.

The regulators supplied in Kits 124 & 125 are capable of supplying 1.5A over an input voltage range of 1.2V to 37V. They need at least a 2.5V input-output voltage differential. In practice the limiting factor on the output voltage & current will be the power dissipated by the regulator. For example, if the input voltage is 30V &

PARTS LIST - KIT 124

Resistors (0.25W, 5%)

330	R1	1
1K	R2	1
10K 10-turn trimpot.....	VR1	1

Capacitors

100nF ceramic	C2,4	2
2200uF 50V electrolytic	C1	1
10uF 63V electrolytic	C3,4	2

Semiconductors

1N5403	D1-6.....	6
LM317T.....	REG	1
3-Terminal Adjustable Regulator, TO-220 case		

Miscellaneous

2 way screw terminal	X2	2
block		
3 way screw terminal	X1	1
block		
Heatsink for regulator		1
3mm screw and nut for bolting regulator		1
to heatsink		
K124 PCB.....		1

the output voltage is 10V and the output current is 1A then the power dissipated by the heatsink is $(30-10)*1$ or 20W. This would need a big heatsink. So it is desirable to keep the input voltage as low as possible to achieve the required output

HOW TO CONTACT US

Visit our web site at “<http://kitsrus.com>”

or send email to “sales@kitsrus.com”

You may email the designer of the kit, Frank Crivelli, at ozitronics@c031.aone.net.au

