

*Author: Steven Dawson  
Microchip Technology Inc.*

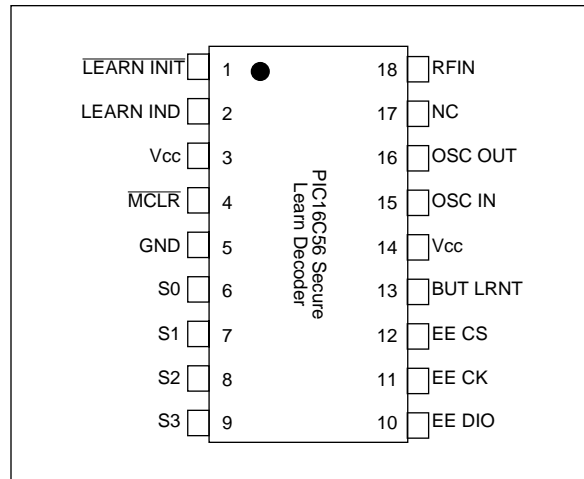
### OVERVIEW

This application note fully describes the working of a code hopping decoder implemented on a Microchip PIC16C56 microcontroller. This decoder uses the secure learn (seed-based) method of learning new transmitters. This application note describes the various KEELOQ® code hopping encoders that can be used with the decoder, the decoder hardware, and the various software modules comprising the system. The software can be used to implement a stand alone decoder or integrate with full function security systems. The decoder supports the Microchip HCS200, HCS300, HCS301, HCS360, HCS361 and HCS410 KEELOQ Code Hopping Encoders.

### KEY FEATURES

- Stand alone decoder
- Compatible with Microchip HCS200, HCS300, HCS301, HCS360 HCS361 and HCS410 encoders
- Automatic bit rate detection
- Automatic encoder type detection
- Four function outputs
- Six learnable transmitters
- RC Oscillator

**FIGURE 1: PIC16C56 DECODER**



### Notice:

**This is a non-restricted version of Application Note AN652 which is available under the KEELOQ License Agreement. The license agreement can be ordered from the Microchip Literature Center as DS40149.**

KEELOQ is a registered trademark of Microchip Technology, Inc.  
 Microchip's Secure Data Products are covered by some or all of the following patents:  
 Code hopping encoder patents issued in Europe, U.S.A., and R.S.A. — U.S.A.: 5,517,187; Europe: 0459781; R.S.A.: ZA93/4726  
 Secure learning patents issued in the U.S.A. and R.S.A. — U.S.A.: 5,686,904; R.S.A.: 95/5429  
 Microwire is a registered trademark of Motorola

## INTRODUCTION TO KEELOQ ENCODERS

All KEELOQ encoders use the KEELOQ code hopping technology to make each transmission by an encoder unique. The encoder transmissions have two parts. The first part changes each time the encoder is activated and is called the hopping code part and is encrypted. The second part is the unencrypted part of the transmission, principally containing the encoder's serial number identifying it to a decoder. Refer to DS91002, *Introduction to KEELOQ*.

### Hopping Code

The hopping code contains function information, a discrimination value, and a synchronization counter. This information is encrypted by an encryption algorithm before being transmitted. A 64-bit encryption key is used by the encryption algorithm. If one bit in the data that is encrypted changes, the result is that an average of half the bits in the output will change. As a result, the hopping code changes dramatically for each transmission and can not be predicted.

### Function Information

The encoder transmits up to four bits of function information. Up to 15 different functions are available.

### Discrimination Value

Stored in the encoder EEPROM, this information can be used to check integrity of decryption operation by a decoder. If known information is inserted into the transmitted string before encryption, the same information can be used at the decoder to check whether the information has been decrypted correctly. In the Microchip HCS encoders, up to 12 bits (including overflow bits) are available.

### Synchronization Counters

The transmitted word contains a 16-bit synchronization counter. The synchronization information is used at the decoder to determine whether a transmission is valid or is a repetition of a previous transmission. Previous codes are rejected to safeguard against code grabbers.

The HCS300, HCS301 and HCS410 encoders transmit two overflow bits which may be used to extend the range of the synchronization counter from 65,536 to 196,608 button operations. The HCS360 and HCS361 encoders transmit one overflow bit which can be used to extend the range of the synchronization counter from 65,536 to 131,071 button operations.

### Unencrypted Code

#### Serial Number

The encoder's serial number is transmitted every time the button is pressed. The serial number is transmitted unencrypted as part of the transmission and serves to identify the encoder to the decoder.

#### Other Status and Function Information

The HCS200, HCS300, and HCS301 encoders include provision for four bits of function information and two status bits in the fixed code portion of its transmission. The two status bits indicate whether a repeated transmission is being sent, and whether the battery voltage is low. The HCS200 does not send repeated transmission information, and the bit is permanently set to '0'.

The HCS360/361 encoders transmit two bits that are used as a Cyclic Redundancy check. These bits can be used to check the integrity of the reception. Additionally, the HCS360 and HCS361 encoders can extend the length of the serial number from 28 bits to 32 bits, replacing the unencrypted function code.

#### Seed Transmissions

The Microchip HCSXXX encoders all have the ability to transmit a fixed seed. The seed value is programmed into the encoder when the encoder is first initialized along with the counters, key, serial number, and other information. The seed length differs from encoder to encoder with the HCS200, HCS300, and HCS301 having a 32-bit seed. The HCS360 and HCS361 encoders have a 48-bit seed. The HCS410 has a 60-bit seed. Table 1 summarizes seed transmissions in the Microchip HCSXXX encoders.

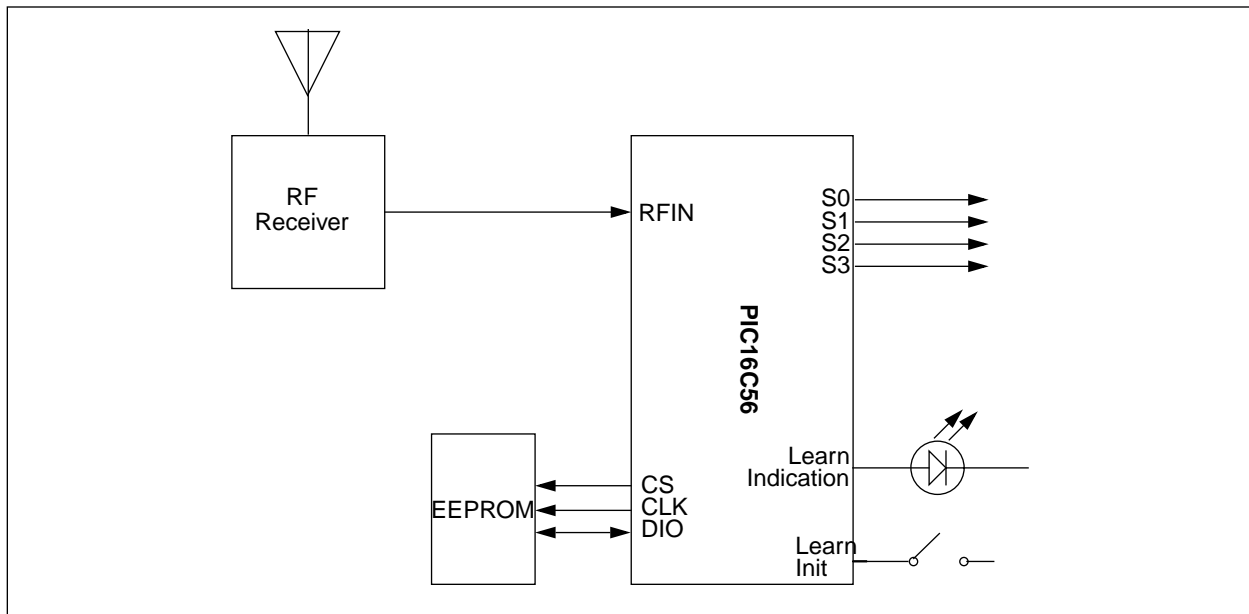
**TABLE 1: KEELOQ ENCODER SEED TRANSMISSION SUMMARY**

Encoder	Seed Length	Seed Transmission Activation
HCS200	32 bits	Seed transmitted immediately if S0, S1, and S2 are activated.
HCS300	32 bits	Seed transmitted immediately if S0, S1, S2, and S3 are activated.
HCS301	32 bits	Seed transmitted immediately if S0, S1, S2, and S3 are activated.
HCS360	48 bits	Seed transmitted immediately if S0 and S3 are activated. Seed transmitted after 3 seconds if S0 and S1 are activated.
HCS361	48 bits	Seed transmitted immediately if S0 and S3 are activated. Seed transmitted after 3 seconds if S0 and S1 are activated.
HCS410	60 bits	Seed transmitted immediately if S0, S1 and S2 are activated. Seed transmitted after 3 seconds if S0 and S1 are activated.

## Transmission Format Summary

Table 2 contains a summary of the information contained in transmissions from each of the KEELOQ encoders that can be learned by the Microchip decoder.

**FIGURE 2: DECODER BLOCK DIAGRAM**



**TABLE 2: KEELOQ ENCODER TRANSMISSION SUMMARY**

	HCS200/201 # of bits	HCS300/301 # of bits	HCS360/361 # of bits	HCS410 # of bits
Total Transmission Length	66	66	67	69
Code Hopping Portion	32	32	32	32
Sync Counter	16	16	16	16
Discrimination bits	12	10	8	10
User Bits	0	0	2	0
Overflow Bits	0	2	1	2
Independent Mode	0	0	1	0
Function Code	4	4	4	4
Fixed Portion	34	34	35	37
Serial number	28	28	28/32	28/32
Function Code	4	4	4/0	4/0
Low Voltage Indicator	1	1	1	1
Repeat Bit	1	1	0	0
CRC	0	0	2	2
Queue Bits	0	0	0	2

**TABLE 3: HCS200/201 AND HCS300/301 CODE HOPPING TRANSMISSION FORMAT**

Code Hopping Portion			Fixed Portion		
Sync Counter	Discrimination	Func	Serial Number	Func	VLOW REPT

**TABLE 4: HCS200/201 AND HCS300/301 SEED TRANSMISSION FORMAT**

Seed Portion	Fixed Portion		
Seed	Serial Number	Func	VLOW REPT

**TABLE 5: HCS360/361 CODE HOPPING TRANSMISSION FORMAT**

Code Hopping Portion			Fixed Portion		
Sync Counter	Discrimination OVR, IND	Func	Serial Number (28/32 bits)	Func (4/0 bits)	VLOW REPT

**TABLE 6: HCS360/361 SEED TRANSMISSION FORMAT**

Seed Portion	Fixed Portion		
Seed (48 bits)	Serial Number (12/16 MS bits)	Func (4/0 bits)	VLOW REPT

**TABLE 7: HCS410 CODE HOPPING TRANSMISSION FORMAT**

Code Hopping Portion			Fixed Portion		
Sync Counter	Discrimination OVR	Func	Serial Number (28/32 bits)	Func (4/0 bits)	VLOW CRC QUE

**TABLE 8: HCS410 SEED TRANSMISSION FORMAT**

Seed Portion	Fixed Portion	
Seed (60 bits)	Func (4/0 bits)	VLOW CRC QUE

## PWM Format

In general, all KEELOQ encoders share a common transmission format:

A **preamble** to improve biasing of decision thresholds in super-regenerative receivers. The preamble consists of alternate on and off periods, each lasting as long as a single elemental period.

A **calibration** header consisting of a low period of 10 elemental periods. Calibration actions should be performed on the low period of the header to ensure correct operation with header chopping.

A **string** of pulse-width modulated bits, each consisting of three elements. The first element is high, the second contains the data transmitted and is either high or low, the third element is always low.

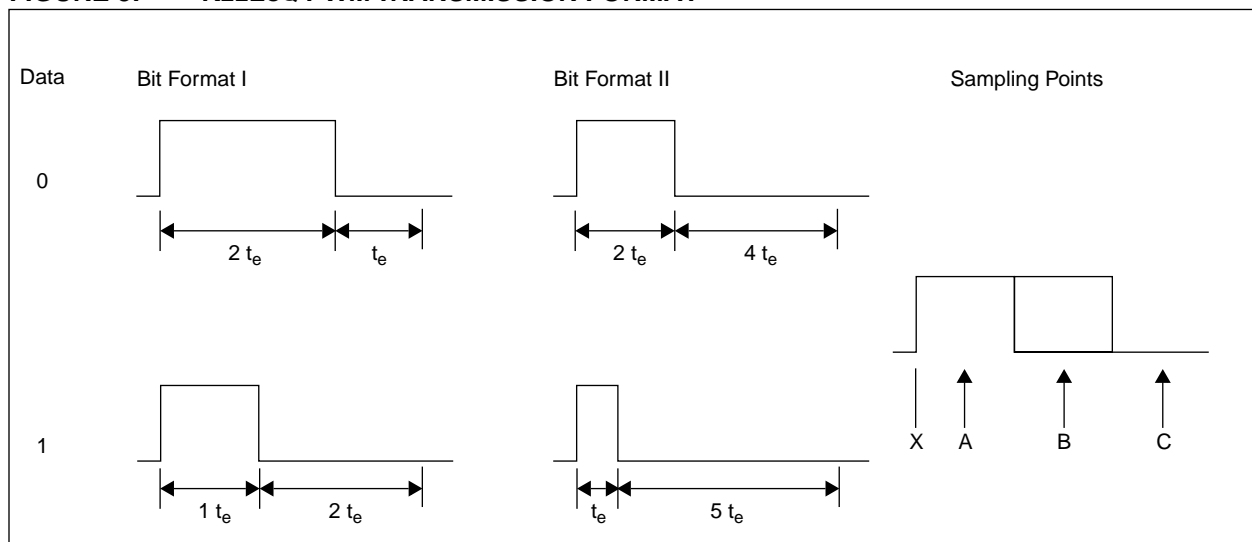
A **guard** period is usually left between the transmissions. During this period nothing is transmitted by the encoder.

Figure 3 shows the sampling points when sampling the data bits. The first and last elements are used exclusively to verify the integrity of the received symbol. The first element (sample point A) is always high, the second (sample point B) is the complement of the data bit being sent, and the final element (sample point C) is always low. Because the period between the low portion of a bit (sample point X) can vary, the rising edge of the first element (sample point X) is used to resynchronize the receiving routine to each incoming bit.

If random noise is being received, the probability of a set of three samples producing a valid combination is only  $2^{-2} = 1/4$ . For a string of 66 bits, the corresponding figure is  $2^{-134}$ .

Integrity checking on incoming signals is important. Code hopping signals require significant processing, as well as EEPROM access, to decrypt. Unnecessary processing can be avoided by not attempting to decrypt incoming codes that have bit errors.

**FIGURE 3: KEELOQ PWM TRANSMISSION FORMAT**



## DECODER IMPLEMENTATION

The Microchip decoder's primary hardware components are a PIC16C56 RISC microcontroller and a 93LC46B EEPROM as shown in the decoder schematic in Figure 10. However, this solution can be implemented in any PICmicro® microcontroller with at least 1K words of program memory. The operating frequency of the controller is 4 MHz. The microcontroller is used to capture transmissions from the various encoders, decrypt transmissions captured, and check the validity of the transmission based on the information in the decrypted transmission and information stored in the EEPROM. If a transmission from a valid encoder is received, the decoder activates the outputs dictated by the transmission.

Encoder information, such as serial number, synchronization information, and decryption key is stored externally in an EEPROM. The EEPROM used is a Microchip 93LC46B Microwire® Serial EEPROM. The information stored in the EEPROM is encrypted to protect the contents. The EEPROM encryption is less secure than the KEELOQ code hopping algorithm.

As can be seen from the section on encoder transmissions, there are differences in the transmission formats of the different encoders that can be used with the decoder. The following section summarizes how the differences in transmitted data are dealt with by the decoder.

As the serial number information follows after the code hopping portion of the transmission, any number of serial number bits can be received and processed. In the Microchip decoder described, the complete serial number (28 bits) is stored.

The serial number is used to identify the memory block used to store the 64-bit decryption key for a particular encoder because of the relationship between serial number, seed, and the decryption key. In other words, the serial number is stored with the key. When a transmission is received, the decoder finds the correct memory block by checking all blocks until a matching serial

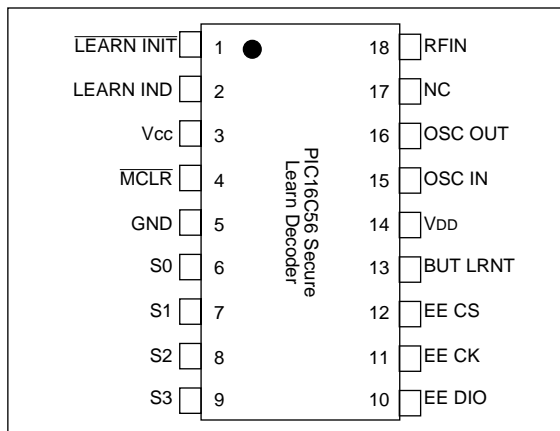
number is found. The key is then retrieved from that particular memory block. A serial number of 0000000<sub>16</sub> is considered invalid and is ignored by the decoder.

After matching the received and stored serial number, validation of a received transmission consists of two steps. The first includes checking the integrity of the decryption operation. Here the decoder compares the 12-bit discrimination value received with the stored discrimination value. The discrimination value stored with the HCS300/301/360/361/410 includes overflow bits and user bits.

The second portion of validation involves checking synchronization information for that particular encoder. The synchronization counter transmitted by all encoders is 16 bits long. Two copies of the full synchronization counter are stored for all valid encoders. The storing of two copies of the synchronization information protects the decoder from losing synchronization with an encoder if one of the counters is corrupted.

## PINOUTS OF MICROCHIP KEELOQ DECODER

**FIGURE 4: FUNCTIONAL INPUTS AND OUTPUTS**



**TABLE 9: MICROCHIP DECODER FUNCTIONAL INPUTS AND OUTPUTS**

Mnemonic	Pin Number	Input / Output	Function
RF IN	18	I	Demodulated PWM signal from RF receiver. The decoder uses this input to receive encoder transmissions.
LEARN INIT	1	I	Input to initiate learning, active low.
LEARN IND	2	O	Output to show the status of the learn process (in an integrated system this will be combined with the system status indicator).
BUT LRNT	13	O	Indication that the received function code matches the learned function code.
S0, S1, S2, S3	6, 7, 8, 9	O	Function outputs—corresponds to encoder input pins.

## PROGRAM FLOW

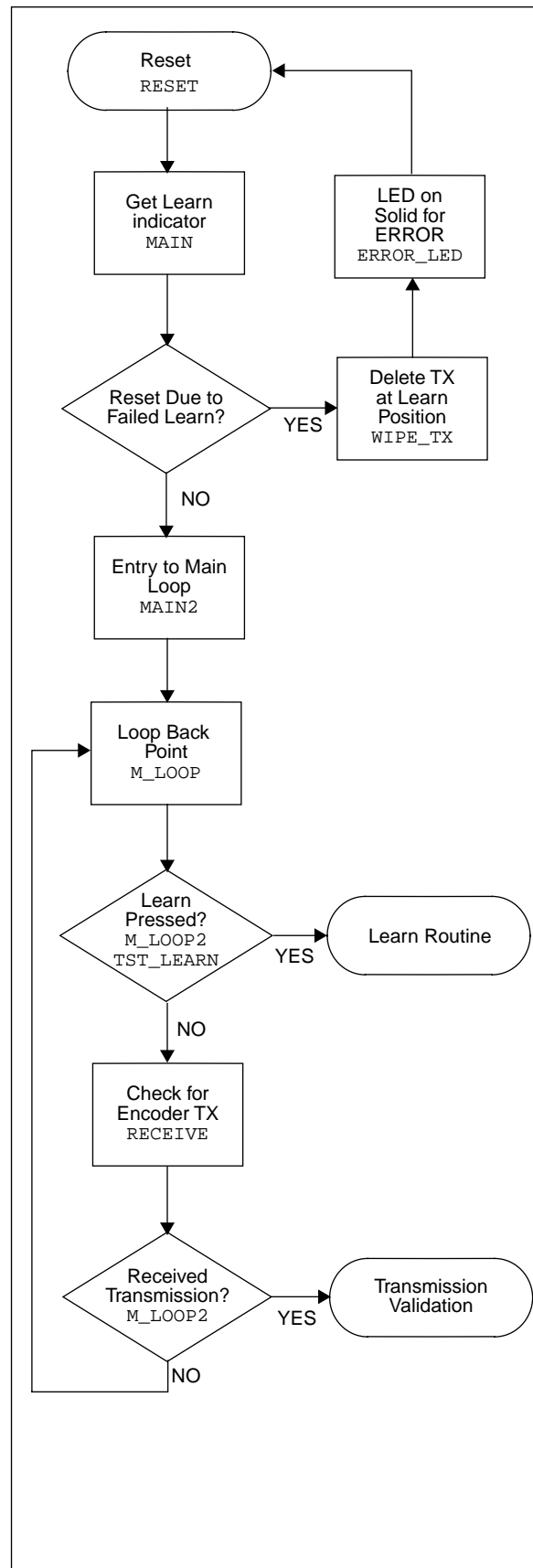
The software for the Microchip decoder has been written for the PIC16C56 microcontroller. The compiler used is MPASM version 01.30.01. The operating frequency of the PIC16C56 is 4 MHz. The clock speed should be kept as close as possible to 4 MHz as the reception routine (*RECEIVE*) is dependent on the 4 MHz clock for correct functioning. Other decoder functions that rely on a 4 MHz clock speed are the hold times of the various outputs and time-outs. The main program flow is described here. Detailed descriptions of individual functions can be found further in the application note.

As can be seen from Figure 5, the decoder reads the learn indicator, which stores the next position to be overwritten when the decoder enters a learn sequence and decoder status flags, from the external EEPROM on power-up. The status flags are checked to see if a learn routine was interrupted when the microcontroller was reset. If so, it is assumed the learn cycle was not successfully completed, and the encoder at the learn indicator is subsequently deleted (*WIPE\_TX*).

The encoder then enters the main loop where it spends most of its time. The main loop checks to see if the learn button is being activated (*TST\_LEARN*). If so, the decoder enters the learn mode described in the "Learn" section in AN652.

If learn has not been initiated, the microcontroller then checks for transmissions from encoders (*RECEIVE*). If a transmission from an encoder has successfully been received, the microcontroller validates the transmission received as described in the "Transmission Validation" in AN652. If the transmission received is a valid transmission from an encoder learned into the system, the system sets the appropriate outputs (*M\_BUT*).

**FIGURE 5: MICROCHIP DECODER MAIN PROGRAM FLOW**



## FUNCTIONAL MODULES

### Reception

The reception routine (`RECEIVE`) is based on a reliable algorithm which has successfully been used in previous implementations of KEELQ decoders. Automatic bit-rate detection is used to compensate for variations in bit rate of different encoders of a specific type, as well as the differences in bit rate between different encoders (HCS200, HCS300, and HCS360). The reception routine is able to receive 64-bit transmissions. This is easily extended to receive more bits. The reception routine is able to determine the number of bits in the transmission.

The reception algorithm performs a number of functions when an output is detected from the receiver. Figure 6 gives all the major sampling points in the reception algorithm.

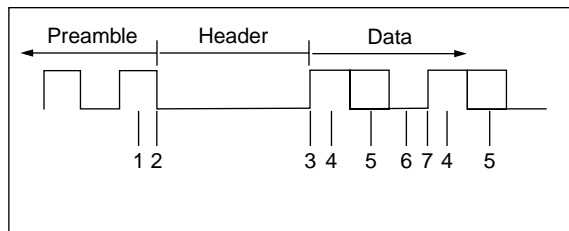
The reception algorithm calibrates on the low period of the header to determine the actual elemental period for the transmission being received. The required elemental period is 10% of the low header period. In Figure 6 the header calibration sample points are marked 1 through 3. The calibration flow chart (Figure 7) shows at what points in the program samples 1, 2, and 3 are taken.

Elemental periods outside the capture range of the algorithm (either too long or too short) are rejected, since they are due either to noise or to reception of an incomplete signal.

Using the determined elemental period, three samples after the first rising edge (Sample 3) following the header are taken. The first sample is taken half an elemental period after the rising edge (Sample 4); the second, one elemental period later (Sample 5), and the third, another one elemental period later (Sample 6). The first sample must be high, the second could be either high or low, and the third sample must be low. If either the first or the third sample is not as expected, the attempt at capturing a transmission is abandoned. In Figure 6, the data sample points are points 4 through 6. The flow chart describing data reception (Figure 8) shows where in the code the samples are taken.

If all 66 bits have been captured, each with the correct first and third elements, the transmission can be assumed to be correct, and decryption can commence. The receiving routine should be called often enough to ensure that the high portion in the header is not missed (Sample 1, Figure 6).

**FIGURE 6: SAMPLING POINTS USED IN RECEIVE ALGORITHM**



In systems where the reception routine is called to check if there is activity on the receiver input, the routine should poll the input for a valid transmission for at least the time taken to complete one transmission if activity is detected on the input line. This makes provision for the reception routine being called while a transmission is in progress. Having missed the first header, the first transmission will be invalid and be discarded. The decoder should continue sampling the input through the guard time in order to catch the next header and transmission (i.e., for a decoder designed to capture HCS300 transmissions the time spent polling for a valid transmission should be at least 100 ms if activity is detected in the input line).

### Reception Algorithm Flow Chart

The first flow chart (Figure 7) describes the calibration routine which is used to determine the actual transmission rate of the encoder so that the decoder can compensate for deviations from nominal timing. There are four different exit points, each of which should branch to a point in the program where housekeeping and input monitoring can be resumed. There is only one exit point for a valid calibration operation (`RCV7`). At this point, it is assumed that a valid header has been received and that a string of data bits will follow.

The second flow chart (Figure 8) handles the reception of bits once the calibration routine has been successfully completed. The data bits are all sampled three times each to ensure that a noise free transmission has been received. The reception routine uses the calibrated elemental period, determined in the calibration routine, to ensure that the samples are correctly spaced. The routine resynchronizes itself on the rising flank of each bit. Only 60 bits of the data received are used by the Microchip decoder described, the decoder ignores the unencrypted function code and the status bits.

If the control samples in a given bit are sampled correctly (i.e., the first element is high and the last element is low), the routine checks whether more than 56 bits have been received correctly. If not, the routine returns to the calling procedure.



**FIGURE 7: CALIBRATION FLOW CHART**

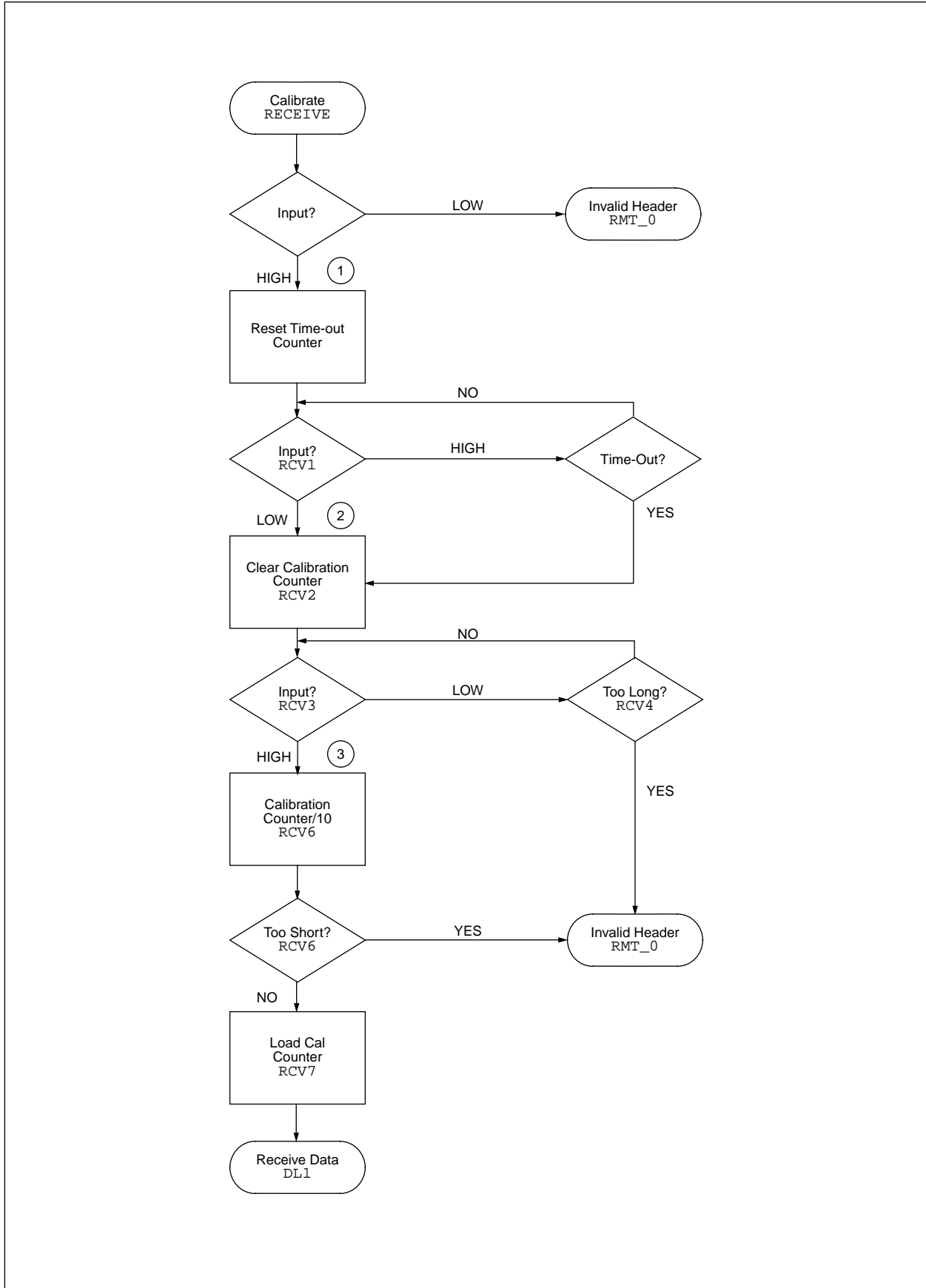
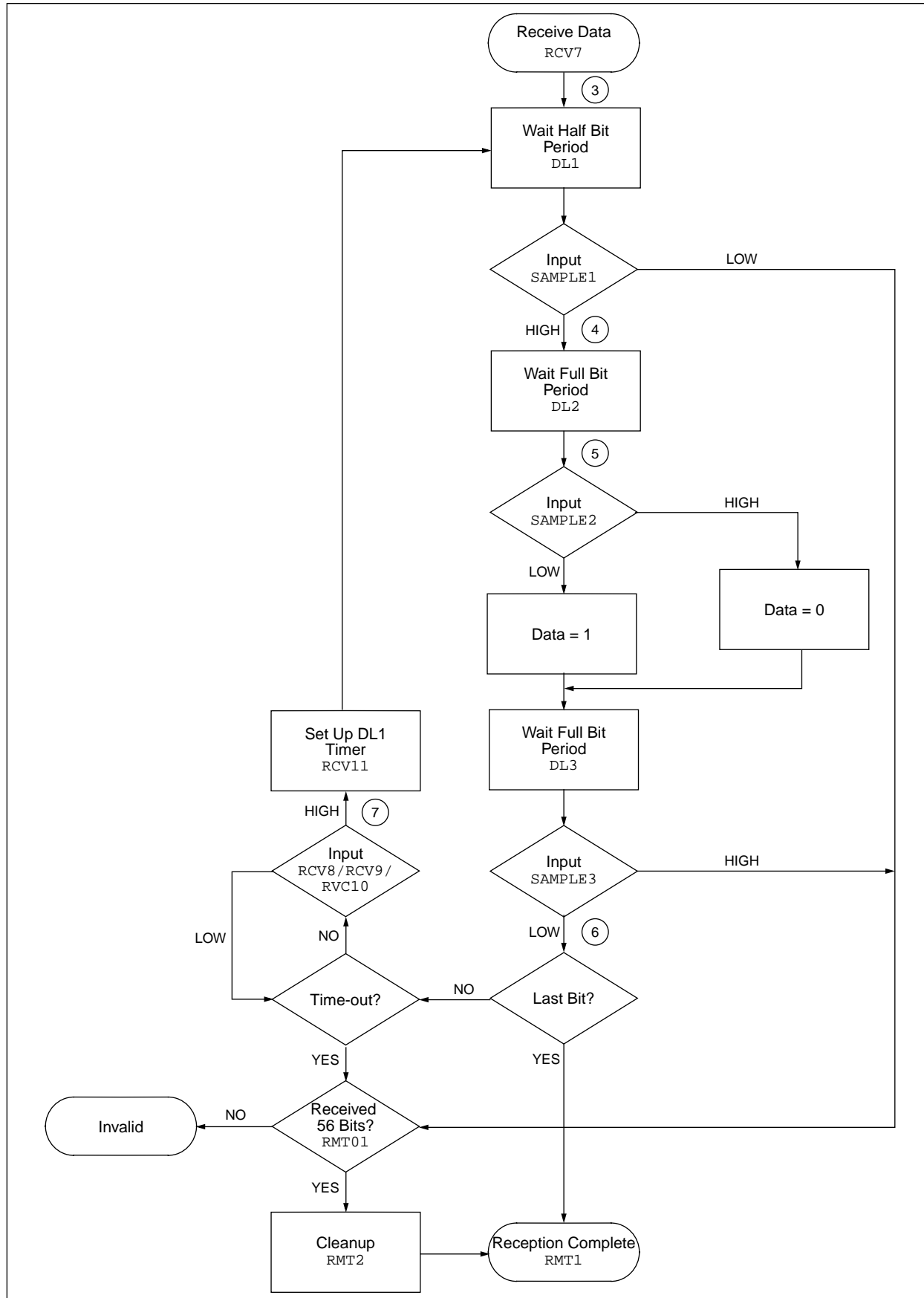


FIGURE 8: DATA RECEPTION FLOW CHART



**VALIDATION**

**SYNCHRONIZATION**

**FUNCTION INTERPRETATION**

**OUTPUT ACTIVATION**

**KEY GENERATION**

**DECRYPTION**

**LEARN**

**ROM MEMORY MAP**

**EEPROM MEMORY MAP**

**RAM MEMORY MAP**

**The confidential and proprietary information contained in this section of AN652 has been removed. The full application note is available under a license agreement and can be ordered as DS40149 from Microchip Technology Inc.**

## DEVICE PINOUTS

The device used in the application note is a PIC16C56 PDIP.

**TABLE 10: DEVICE PINOUTS**

PIN	PIC16C56 Function	Decoder Function	PIN	PIC16C56 Function	Decoder Function
1	Port A Bit 2	LEARN Input	18	Port A Bit 1	RF Input
2	Port A Bit 3	LRN INDICATOR	17	Port A Bit 0	Not used
3	TIMER0	Connect to VDD	16	Osc In	RC osc (4 MHz)
4	MCLR	Brown out detect	15	Osc Out	
5	GND	Ground	14	VDD	+5V supply
6	Port B Bit 0	S0	13	Port B Bit 7	BUT LRNT
7	Port B Bit 1	S1	12	Port B Bit 6	CS (93LC46B, pin 1)
8	Port B Bit 2	S2	11	Port B Bit 5	CLK (93LC46B, pin 2)
9	Port B Bit 3	S3	10	Port B Bit 4	DIO (93LC46B, pin 3 & 4)

## TIMING PARAMETERS

**TABLE 11: TIMING PARAMETERS**

Parameter	Typical	Unit
Output activation duration	524	ms
Output pause if new function code received	131	ms
Erase all duration	8.4	s
Learn mode time-out	33.6	s
Learn successful LED flash duration	4.2	s
Learn successful LED flash rate	3.8	Hz
Learn failure LED on duration	1	s

## SOURCE CODE LISTING

A diskette is supplied containing source code for the Microchip decoder in the file `MSLRN**.ASM`. The code has been compiled using MPASM v01.30.01. Certain functions are dependent on the oscillator speed for correct functioning. Examples of time dependent functions include `RECEIVE` and `TST_RTCC`. The PIC16C56 Microcontroller should run at 4 MHz.

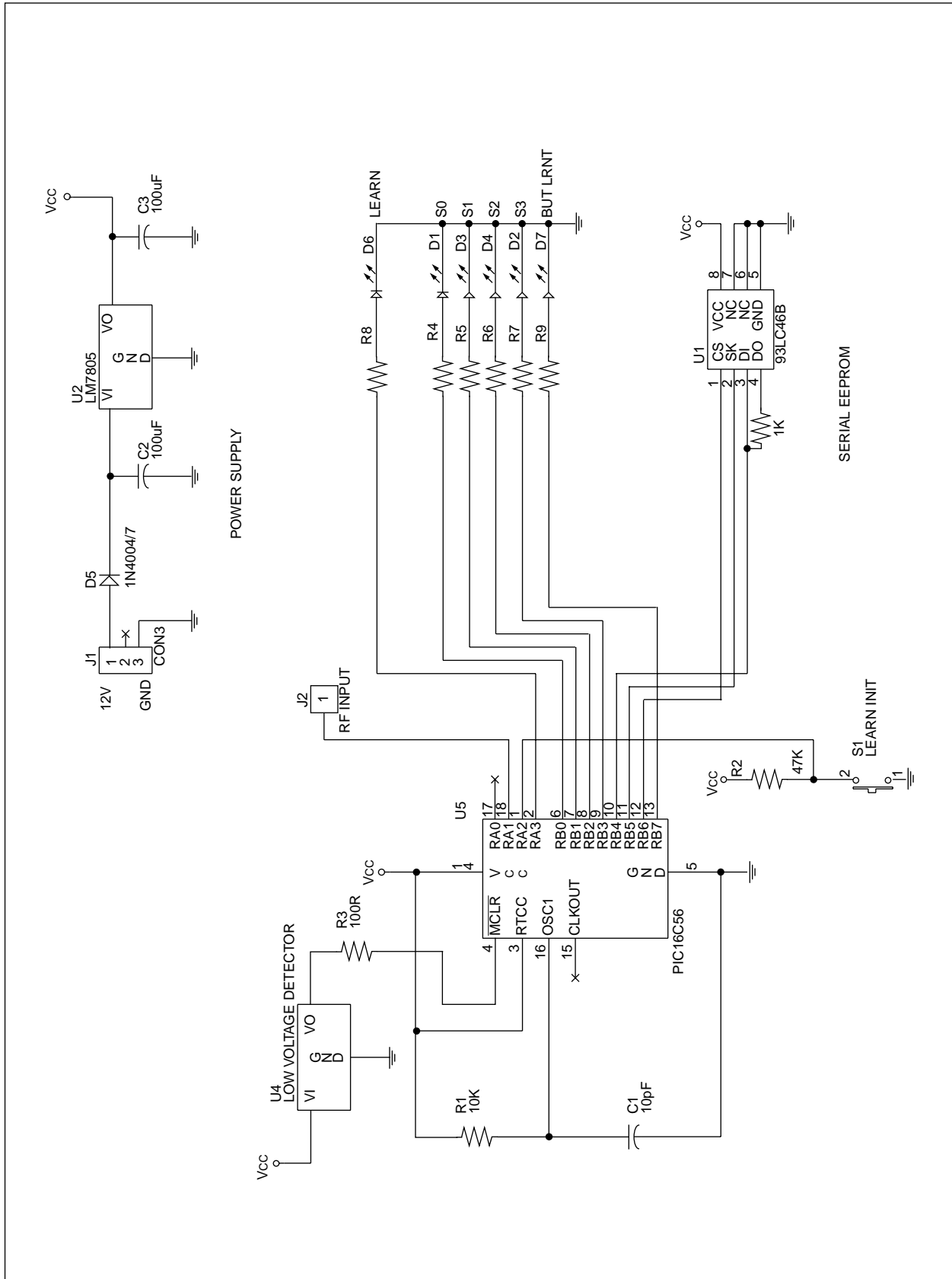
**TABLE 12: LIST OF IMPORTANT FUNCTIONS**

Function Name	Description
CALC_KEY	Key generation routine.
DECRYPT	Decryption routine for Hop Code.
EEREAD	The data in the EEPROM at ADDRESS is read and decrypted to TMP1 and TMP2 (Note).
EEWRITE	The data in TMP1, and TMP2 is encrypted and written to the EEPROM at ADDRESS (Note).
M_DIS	Check discrimination value.
M_CNT	Check synchronization (counter) values.
RECEIVE	Start of the RF reception routine.
TST_LEARN1	Check for learn mode and entry to learn.
TST_RTCC	Check TIMER0 and do whatever real time tasks are required.

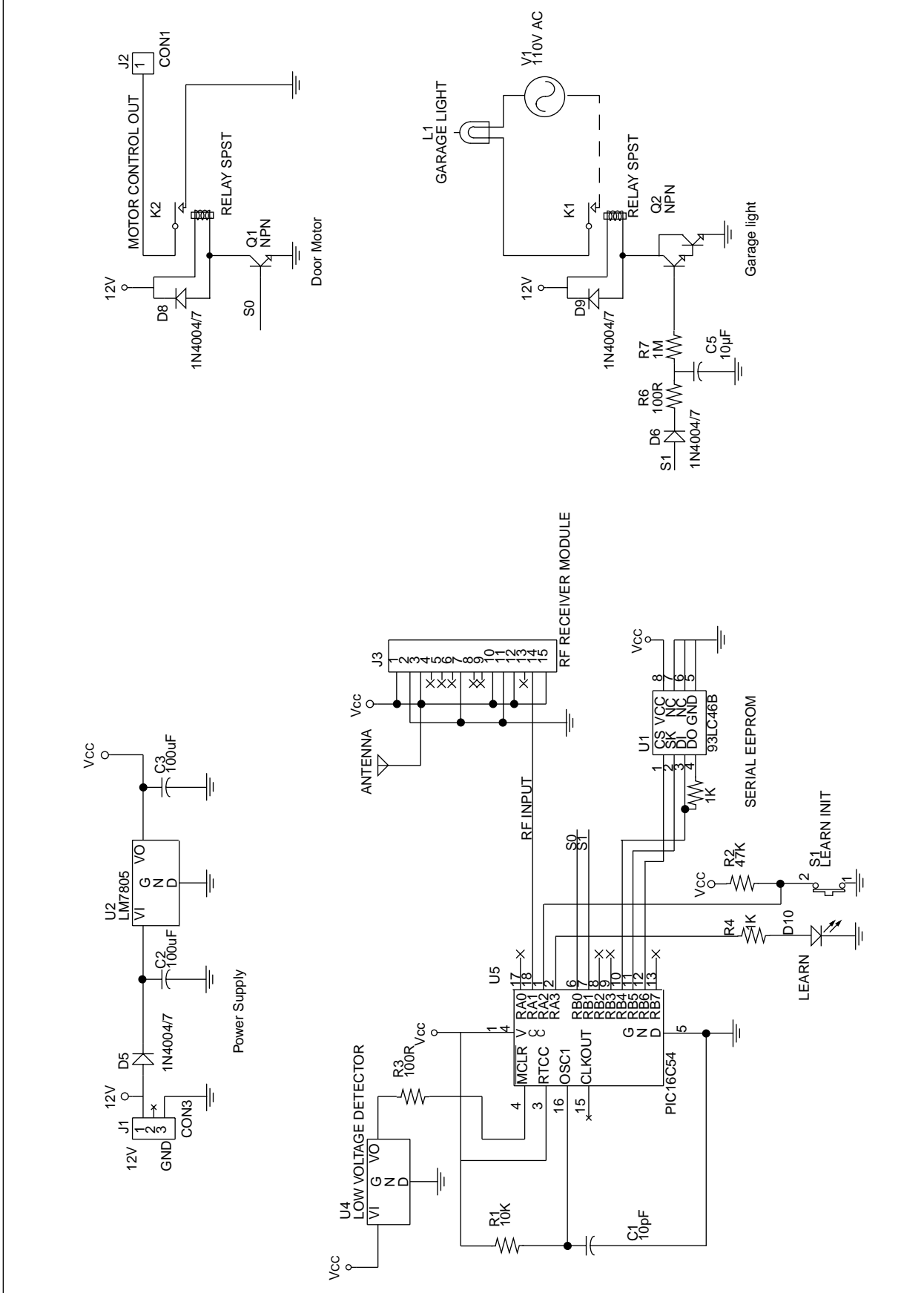
**Note:** TMP1, TMP2 and ADDRESS are user defined registers.

## APPENDIX A: SCHEMATIC DIAGRAMS

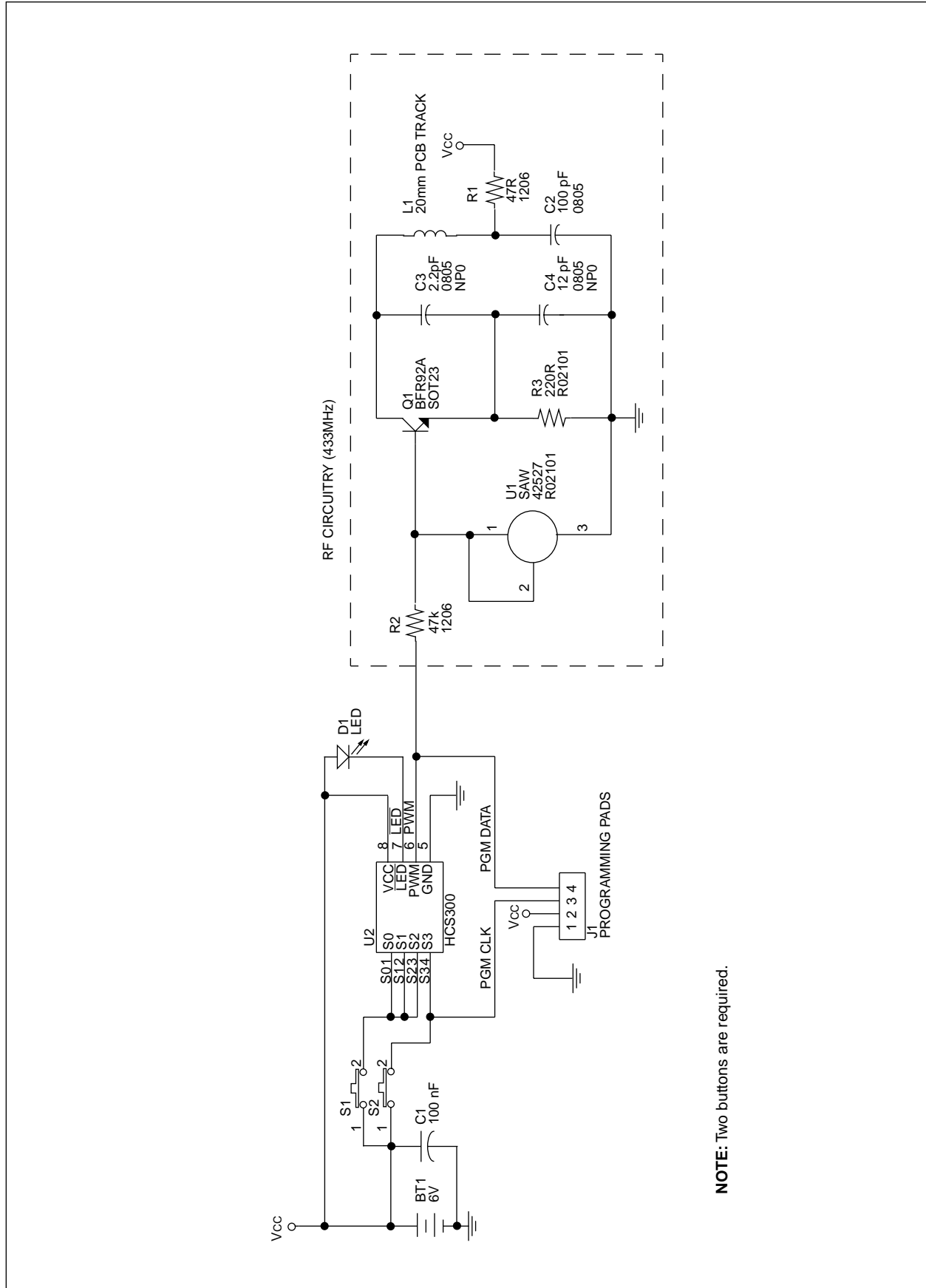
FIGURE 9: SCHEMATIC DIAGRAM OF MICROCHIP KEELoQ DECODER



**FIGURE 10: TYPICAL GARAGE DOOR OPENER SCHEMATIC**

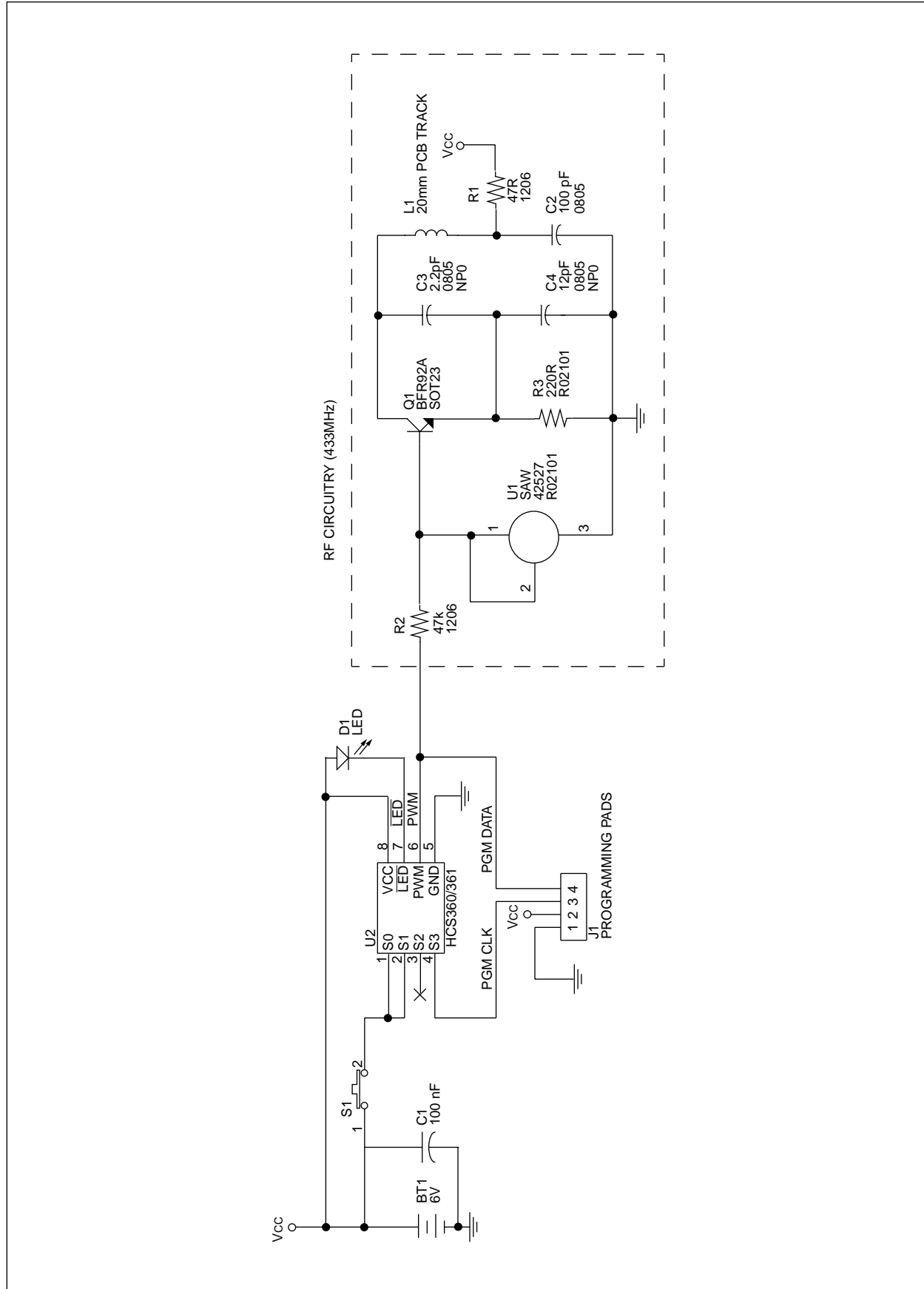


**FIGURE 11: HCS200/300/301 TRANSMITTER DESIGN**



**NOTE:** Two buttons are required.

FIGURE 12: HCS360/361 SINGLE BUTTON TRANSMITTER DESIGN





**NOTES:**

# AN662

---

NOTES:

NOTES:

---

---

**Note the following details of the code protection feature on PICmicro® MCUs.**

- The PICmicro family meets the specifications contained in the Microchip Data Sheet.
- Microchip believes that its family of PICmicro microcontrollers is one of the most secure products of its kind on the market today, when used in the intended manner and under normal conditions.
- There are dishonest and possibly illegal methods used to breach the code protection feature. All of these methods, to our knowledge, require using the PICmicro microcontroller in a manner outside the operating specifications contained in the data sheet. The person doing so may be engaged in theft of intellectual property.
- Microchip is willing to work with the customer who is concerned about the integrity of their code.
- Neither Microchip nor any other semiconductor manufacturer can guarantee the security of their code. Code protection does not mean that we are guaranteeing the product as “unbreakable”.
- Code protection is constantly evolving. We at Microchip are committed to continuously improving the code protection features of our product.

If you have any further questions about this matter, please contact the local sales office nearest to you.

---

Information contained in this publication regarding device applications and the like is intended through suggestion only and may be superseded by updates. It is your responsibility to ensure that your application meets with your specifications. No representation or warranty is given and no liability is assumed by Microchip Technology Incorporated with respect to the accuracy or use of such information, or infringement of patents or other intellectual property rights arising from such use or otherwise. Use of Microchip's products as critical components in life support systems is not authorized except with express written approval by Microchip. No licenses are conveyed, implicitly or otherwise, under any intellectual property rights.

#### **Trademarks**

The Microchip name and logo, the Microchip logo, FilterLab, KEELOQ, microID, MPLAB, PIC, PICmicro, PICMASTER, PICSTART, PRO MATE, SEEVAL and The Embedded Control Solutions Company are registered trademarks of Microchip Technology Incorporated in the U.S.A. and other countries.

dsPIC, ECONOMONITOR, FanSense, FlexROM, fuzzyLAB, In-Circuit Serial Programming, ICSP, ICEPIC, microPort, Migratable Memory, MPASM, MPLIB, MPLINK, MPSIM, MXDEV, PICC, PICDEM, PICDEM.net, rPIC, Select Mode and Total Endurance are trademarks of Microchip Technology Incorporated in the U.S.A.

Serialized Quick Turn Programming (SQTP) is a service mark of Microchip Technology Incorporated in the U.S.A.

All other trademarks mentioned herein are property of their respective companies.

© 2002, Microchip Technology Incorporated, Printed in the U.S.A., All Rights Reserved.

 Printed on recycled paper.



*Microchip received QS-9000 quality system certification for its worldwide headquarters, design and wafer fabrication facilities in Chandler and Tempe, Arizona in July 1999. The Company's quality system processes and procedures are QS-9000 compliant for its PICmicro® 8-bit MCUs, KEELOQ® code hopping devices, Serial EEPROMs and microperipheral products. In addition, Microchip's quality system for the design and manufacture of development systems is ISO 9001 certified.*



# MICROCHIP

## WORLDWIDE SALES AND SERVICE

### AMERICAS

#### Corporate Office

2355 West Chandler Blvd.  
Chandler, AZ 85224-6199  
Tel: 480-792-7200 Fax: 480-792-7277  
Technical Support: 480-792-7627  
Web Address: <http://www.microchip.com>

#### Rocky Mountain

2355 West Chandler Blvd.  
Chandler, AZ 85224-6199  
Tel: 480-792-7966 Fax: 480-792-7456

#### Atlanta

500 Sugar Mill Road, Suite 200B  
Atlanta, GA 30350  
Tel: 770-640-0034 Fax: 770-640-0307

#### Boston

2 Lan Drive, Suite 120  
Westford, MA 01886  
Tel: 978-692-3848 Fax: 978-692-3821

#### Chicago

333 Pierce Road, Suite 180  
Itasca, IL 60143  
Tel: 630-285-0071 Fax: 630-285-0075

#### Dallas

4570 Westgrove Drive, Suite 160  
Addison, TX 75001  
Tel: 972-818-7423 Fax: 972-818-2924

#### Detroit

Tri-Atria Office Building  
32255 Northwestern Highway, Suite 190  
Farmington Hills, MI 48334  
Tel: 248-538-2250 Fax: 248-538-2260

#### Kokomo

2767 S. Albright Road  
Kokomo, Indiana 46902  
Tel: 765-864-8360 Fax: 765-864-8387

#### Los Angeles

18201 Von Karman, Suite 1090  
Irvine, CA 92612  
Tel: 949-263-1888 Fax: 949-263-1338

#### New York

150 Motor Parkway, Suite 202  
Hauppauge, NY 11788  
Tel: 631-273-5305 Fax: 631-273-5335

#### San Jose

Microchip Technology Inc.  
2107 North First Street, Suite 590  
San Jose, CA 95131  
Tel: 408-436-7950 Fax: 408-436-7955

#### Toronto

6285 Northam Drive, Suite 108  
Mississauga, Ontario L4V 1X5, Canada  
Tel: 905-673-0699 Fax: 905-673-6509

### ASIA/PACIFIC

#### Australia

Microchip Technology Australia Pty Ltd  
Suite 22, 41 Rawson Street  
Epping 2121, NSW  
Australia  
Tel: 61-2-9868-6733 Fax: 61-2-9868-6755

#### China - Beijing

Microchip Technology Consulting (Shanghai)  
Co., Ltd., Beijing Liaison Office  
Unit 915  
Bei Hai Wan Tai Bldg.  
No. 6 Chaoyangmen Beidajie  
Beijing, 100027, No. China  
Tel: 86-10-85282100 Fax: 86-10-85282104

#### China - Chengdu

Microchip Technology Consulting (Shanghai)  
Co., Ltd., Chengdu Liaison Office  
Rm. 2401, 24th Floor,  
Ming Xing Financial Tower  
No. 88 TIDU Street  
Chengdu 610016, China  
Tel: 86-28-6766200 Fax: 86-28-6766599

#### China - Fuzhou

Microchip Technology Consulting (Shanghai)  
Co., Ltd., Fuzhou Liaison Office  
Unit 28F, World Trade Plaza  
No. 71 Wusi Road  
Fuzhou 350001, China  
Tel: 86-591-7503506 Fax: 86-591-7503521

#### China - Shanghai

Microchip Technology Consulting (Shanghai)  
Co., Ltd.  
Room 701, Bldg. B  
Far East International Plaza  
No. 317 Xian Xia Road  
Shanghai, 200051  
Tel: 86-21-6275-5700 Fax: 86-21-6275-5060

#### China - Shenzhen

Microchip Technology Consulting (Shanghai)  
Co., Ltd., Shenzhen Liaison Office  
Rm. 1315, 13/F, Shenzhen Kerry Centre,  
Renminnan Lu  
Shenzhen 518001, China  
Tel: 86-755-2350361 Fax: 86-755-2366086

#### Hong Kong

Microchip Technology Hongkong Ltd.  
Unit 901-6, Tower 2, Metroplaza  
223 Hing Fong Road  
Kwai Fong, N.T., Hong Kong  
Tel: 852-2401-1200 Fax: 852-2401-3431

#### India

Microchip Technology Inc.  
India Liaison Office  
Divyasree Chambers  
1 Floor, Wing A (A3/A4)  
No. 11, O'Shaugnessey Road  
Bangalore, 560 025, India  
Tel: 91-80-2290061 Fax: 91-80-2290062

### Japan

Microchip Technology Japan K.K.  
Benex S-1 6F  
3-18-20, Shinyokohama  
Kohoku-Ku, Yokohama-shi  
Kanagawa, 222-0033, Japan  
Tel: 81-45-471- 6166 Fax: 81-45-471-6122

### Korea

Microchip Technology Korea  
168-1, Youngbo Bldg. 3 Floor  
Samsung-Dong, Kangnam-Ku  
Seoul, Korea 135-882  
Tel: 82-2-554-7200 Fax: 82-2-558-5934

### Singapore

Microchip Technology Singapore Pte Ltd.  
200 Middle Road  
#07-02 Prime Centre  
Singapore, 188980  
Tel: 65-334-8870 Fax: 65-334-8850

### Taiwan

Microchip Technology Taiwan  
11F-3, No. 207  
Tung Hua North Road  
Taipei, 105, Taiwan  
Tel: 886-2-2717-7175 Fax: 886-2-2545-0139

### EUROPE

#### Denmark

Microchip Technology Nordic ApS  
Regus Business Centre  
Lautrup hoj 1-3  
Ballerup DK-2750 Denmark  
Tel: 45 4420 9895 Fax: 45 4420 9910

#### France

Microchip Technology SARL  
Parc d'Activite du Moulin de Massy  
43 Rue du Saule Trapu  
Batiment A - ler Etage  
91300 Massy, France  
Tel: 33-1-69-53-63-20 Fax: 33-1-69-30-90-79

#### Germany

Microchip Technology GmbH  
Gustav-Heinemann Ring 125  
D-81739 Munich, Germany  
Tel: 49-89-627-144 0 Fax: 49-89-627-144-44

#### Italy

Microchip Technology SRL  
Centro Direzionale Colleoni  
Palazzo Taurus 1 V. Le Colleoni 1  
20041 Agrate Brianza  
Milan, Italy  
Tel: 39-039-65791-1 Fax: 39-039-6899883

#### United Kingdom

Arizona Microchip Technology Ltd.  
505 Eskdale Road  
Winnersh Triangle  
Wokingham  
Berkshire, England RG41 5TU  
Tel: 44 118 921 5869 Fax: 44-118 921-5820

01/18/02