

NuDAM-6080
Counter/Frequency
Input Module

@Copyright 1997 ADLink Technology Inc.
All Rights Reserved.

Manual Rev. 1.00: March 26, 1998

The information in this document is subject to change without prior notice in order to improve reliability, design and function and does not represent a commitment on the part of the manufacturer.

In no event will the manufacturer be liable for direct, indirect, special, incidental, or consequential damages arising out of the use or inability to use the product or documentation, even if advised of the possibility of such damages.

This document contains proprietary information protected by copyright. All rights are reserved. No part of this manual may be reproduced by any mechanical, electronic, or other means in any form without prior written permission of the manufacturer.

NuDAM is registered trademarks of ADLink Technology Inc.,
Other product names mentioned herein are used for identification purposes only and may be trademarks and/or registered trademarks of their respective companies.

Contents

1.	Introduction	1-1
1. 1.	<i>About the NuDAM Counter/Frequency Modules.....</i>	<i>1-1</i>
1. 2.	<i>Overview of NuDAM-6080</i>	<i>1-1</i>
	What is NuDAM-6080?	1-1
	Features of NuDAM-6080	1-2
	Specifications of NuDAM-6080	1-2
	Pin Definitions of ND-6080	1-4
	A Look at ND-6080 & Pin Assignment	1-5
	Functional Block Diagram of ND-6080	1-6
2.	Initialization & Installation	2-1
2. 1.	<i>Software Installation.....</i>	<i>2-1</i>
2. 2.	<i>Initializing a Brand-New Module</i>	<i>2-2</i>
	Objective of Initializing a Brand-New NuDAM	2-2
	Default State	2-2
	Initialization Equipment	2-3
	Initialization Procedure	2-3
	Initialization Wiring	2-3
2. 3.	<i>Install a New NuDAM to a Existing Network</i>	<i>2-4</i>
	Equipments for Install a New Module	2-4
	Installing Procedures	2-4
2. 4.	<i>Application Wiring for NuDAM-6080.....</i>	<i>2-5</i>
	Non-isolated Input.....	2-5
	Photo-isolated Input	2-5
3.	Command Set	3-1
3. 1.	<i>Command and Response</i>	<i>3-1</i>
	Introduction	3-1
	Document Conventions	3-1
	Format of NuDAM Commands	3-2
	Response of NuDAM Commands	3-3
3. 2.	<i>Summary of Command Set.....</i>	<i>3-4</i>
3. 3.	<i>Set Configuration.....</i>	<i>3-7</i>
3. 4.	<i>Read Configuration.....</i>	<i>3-10</i>
3. 5.	<i>Read Module Name.....</i>	<i>3-11</i>
3. 6.	<i>Read Firmware Version.....</i>	<i>3-12</i>
3. 7.	<i>Set Input Mode.....</i>	<i>3-13</i>
3. 8.	<i>Read Input Mode</i>	<i>3-14</i>
3. 9.	<i>Read Counter/Frequency Value in HEX Format.....</i>	<i>3-15</i>

3. 10.	<i>Read Counter/Frequency Value in DEC Format</i>	3-16
3. 11.	<i>Set Gate Mode</i>	3-17
3. 12.	<i>Read Gate Mode</i>	3-18
3. 13.	<i>Set Maximum Counter Value</i>	3-19
3. 14.	<i>Read Maximum Counter Value</i>	3-20
3. 15.	<i>Set Initial Count Value</i>	3-21
3. 16.	<i>Read Initial Count Value</i>	3-22
3. 17.	<i>Start/Stop Counter</i>	3-23
3. 18.	<i>Read Start/Stop Counter Status</i>	3-24
3. 19.	<i>Clear Counter</i>	3-25
3. 20.	<i>Read then Clear Overflow Flag</i>	3-26
3. 21.	<i>Enable/Disable Digital Filter</i>	3-28
3. 22.	<i>Read Filter Status</i>	3-29
3. 23.	<i>Set Minimum Input Signal Width at High Level</i>	3-30
3. 24.	<i>Read Minimum Input Signal Width at High Level</i>	3-31
3. 25.	<i>Set Minimum Input Signal Width at Low Level</i>	3-32
3. 26.	<i>Read Minimum Input Signal Width at Low Level</i>	3-33
3. 27.	<i>Set TTL Input High Trigger Level</i>	3-34
3. 28.	<i>Read TTL Input High Trigger Level</i>	3-35
3. 29.	<i>Set TTL Input Low Trigger Level</i>	3-36
3. 30.	<i>Read TTL Input Low Trigger Level</i>	3-37
3. 31.	<i>Enable Alarm</i>	3-38
3. 32.	<i>Disable Alarm</i>	3-39
3. 33.	<i>Set Alarm Limit Value of Counter 0</i>	3-40
3. 34.	<i>Set Alarm Limit Value of Counter 1</i>	3-41
3. 35.	<i>Read Alarm Limit Value of Counter 0</i>	3-42
3. 36.	<i>Read Alarm Limit Value of Counter 1</i>	3-43
3. 37.	<i>Set Digital Output Values</i>	3-44
3. 38.	<i>Read Digital Output and Alarm Status</i>	3-45
3. 39.	<i>Read Command Leading Code Setting</i>	3-47
3. 40.	<i>Change Command Leading Code Setting</i>	3-49
3. 41.	<i>Set Host Watchdog Timer & Safety Value</i>	3-51
3. 42.	<i>Read Host Watchdog Timer & Safety Value</i>	3-53
3. 43.	<i>Host is OK</i>	3-55

1. Introduction

1. 1. About the NuDAM Counter/Frequency Modules

The NuDAM provides a counter / frequency input module, which has two 32 bit counter input channels with built in programmable timer for frequency measure function.

NuDAM-6080: counter/frequency input module with digital output.

1. 2. Overview of NuDAM-6080

What is NuDAM-6080?

ND-6080 is a counter / frequency input module. It has two 32-bit counter input channels with built in programmable timer for frequency measurement and supports both photo isolated and non-isolated input mode. The maximum counting value is 4,294,967,295 for counter input channel and the frequency-input range is from 1 Hz to 100 kHz. A programmable digital filter can be enable for both high and low level minimum signal width to reduce noise spike. Besides the programmable threshold for non-isolated input can further reject noise on the input signal level.

The module provides the counter comparator or the alarm function. The alarm limit of two counters can be set independently by programming. The alarm status can be send to digital output channels if this function is ON. The supervisor of a factory can 'see' or 'hear' the alarm if the digital output channel control a real alarm device. The two digital output channel can be set for general purpose used if the alarm is disable. For example, connecting relay devices to DO channels, the NuDAM-6080 can be used to control the high power devices.

Features of NuDAM-6080

- Two 32 bit counter / frequency input channel
- Two digital output channels of open collector type
- 5000 Vrms isolation voltage for isolated input mode
- External gate control for counter input
- Alarm function with alarm output
- Programmable digital filter for noise rejection
- Programmable threshold setting of trigger level for non-isolated input mode
- Programmable host watchdog timer for host failure protection
- Internal watchdog timer for device failure protection
- Easy programming by software
- Easy installation and wiring

Specifications of NuDAM-6080

✧ **Interface**

- Interface : RS-485, 2 wires
- Speed (bps) : 1200, 2400, 4800, 9600, 19.2K, 38.4K

✧ **Counter Input**

- Two independent 32 bit counters
- Input frequency: 100 kHz max.
- Input mode: Isolated or non-isolated
- Isolated input level:
Logic level 0: +1V max.
Logic level 1: +3.5V to +30V
- Isolation voltage: 5000 Vrms
- Non-isolated input level (programmable threshold):
Logic level 0: 0 to +5V (default = 0.8V)
Logic level 1: 0 to +5V (default = 2.4V)
- Input pulse width > 5 μ sec.
- Programmable digital noise filter:
4 μ sec. to 1.02 msec.
- Alarm comparator on each counter

✧ **Frequency measurement Input**

- Range: 1 Hz to 100 kHz
- Programmable built in gate time: 0.1/1.0 sec.

✧ **Digital Output**

- Channels: Two open collector to 30 V, 30 mA max. load

✧ **Watchdog Function**

- Module internal watchdog timer : 150 ms
- Power failure threshold : 4.65 V
- Safety value : 2 digital output channels
- Host programmable watchdog: 100 ms ~ 25.500 sec.

✧ **Power**

- Power supply : +10V to +30V
- Power consumption: 2.0W

Pin Definitions of ND-6080

Pin #	Signal Name	Description
1	IN0	Non-isolated input of counter 0
2	GATE0	External gate control of counter 0
3	GND	Ground for non-isolated input
4	IN1	Non-isolated input of counter 1
5	GATE1	External gate control of counter 1
6	DEFAULT*	Initial state setting
7	(Y) DATA+	RS-485 series signal, positive
8	(G) DATA-	RS-485 series signal, negative
9	(R) +Vs	Power supply, +10V~+30V
10	(B) GND	Ground
11	GATE1-	Differential negative external gate control of counter 1
12	GATE1+	Differential positive external gate control of counter 1
13	IN1-	Differential negative input of counter 1
14	IN1+	Differential positive input of counter 1
15	GATE0-	Differential negative external gate control of counter 0
16	GATE0+	Differential positive external gate control of counter 0
17	IN0-	Differential negative input of counter 0
18	IN0+	Differential positive input of counter 0
19	DO0	Digital output of channel 0 or counter 0 alarm output
20	DO1	Digital output of channel 1 or counter 1 alarm output

A Look at ND-6080 & Pin Assignment

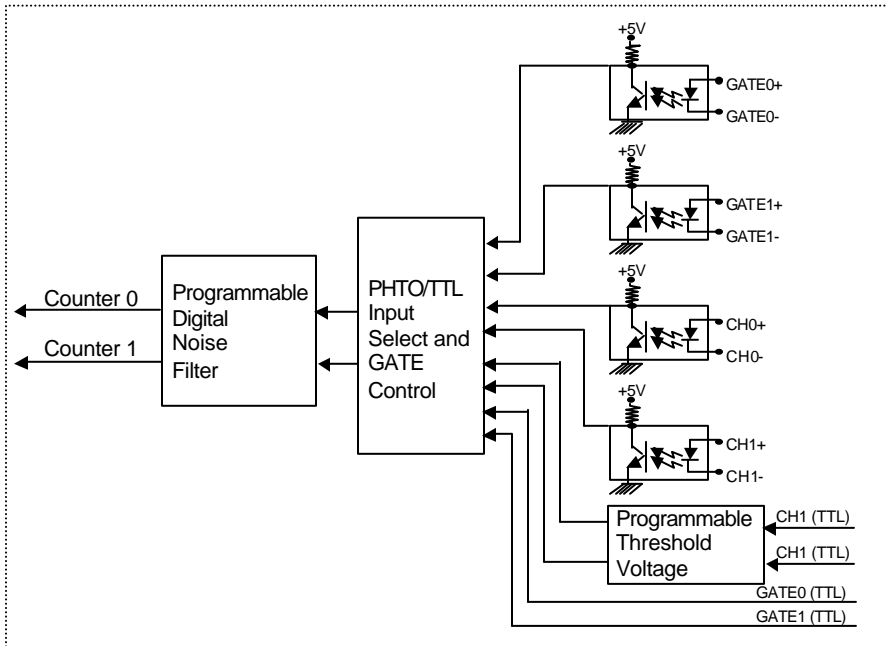
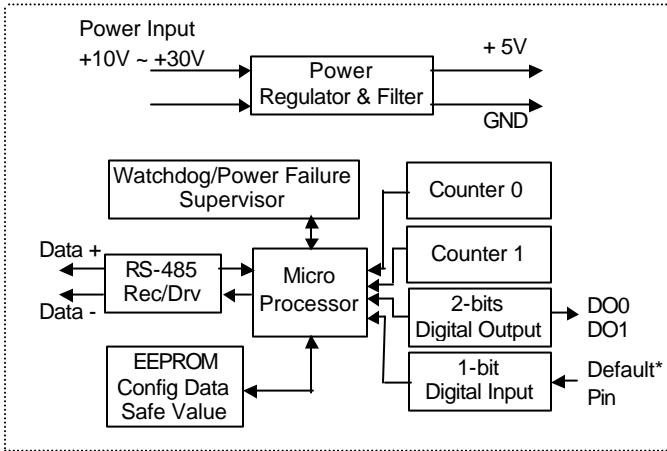

Functional Block Diagram of ND-6080

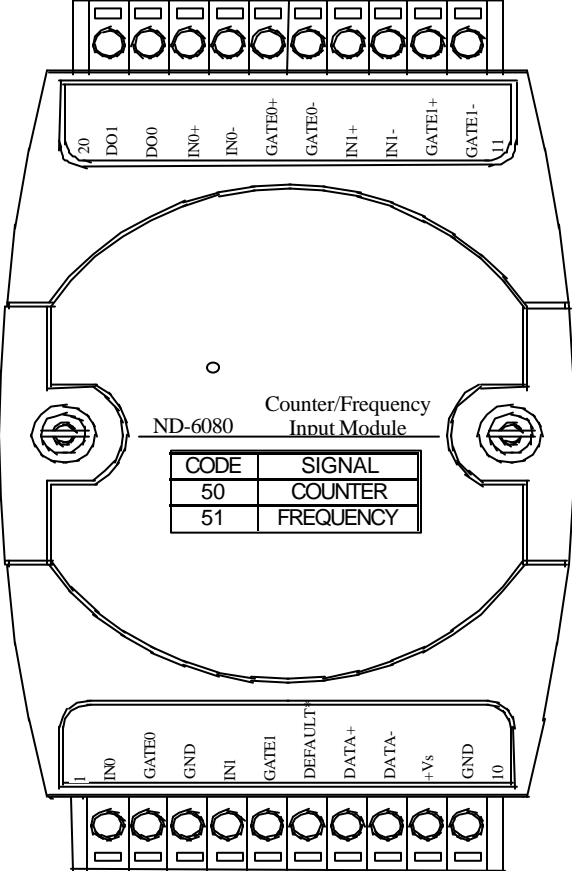

2. Initialization & Installation

2. 1. Software Installation

1. If you had installed “NuDAM Administration” then skip other steps.
2. Backup your software diskette
3. Insert “NuDAM Administration” diskette into floppy drive A:
4. Change drive to A:
5. Installation command syntax

INSTALL drive:
Drive name is C to Z.

Example 1: install to drive C:
A:\> **INSTALL C:**

Example 2: install to drive F:
A:\> **INSTALL F:**

6. NuDAM Administration Utility will be installed in the directory C:\NUDAM

2. 2. Initializing a Brand-New Module

Objective of Initializing a Brand-New NuDAM

All NuDAM modules except NuDAM-6520 and NuDAM-6510, in an RS-485 network must have a *unique* address ID, however, every brand-new NuDAM has a factory default setting as following:

- Address ID is 01.
- Baud rate is 9600 bps
- Check-sum disable
- Host Watchdog timer is disable

Therefore, to configure the brand-new NuDAM before using is necessary, otherwise the address ID will be conflict with others modules because the ID of new modules are identity. The baud rate may also be changed according to user' s requirements.

The following sections show how to initialize a brand-new module, which is applicable for initializing NuDAM-6080.

Default State

The NuDAM I/O modules must be set at *Default State* when you want to change the default settings, such as the baud rate and check-sum status etc. All NuDAM I/O modules have an special pin labeled as **DEFAULT***. The module will be in *Default State* if the **DEFAULT*** pin is shorted to ground when power ON. Under this state, the default configuration is set as following:

- Address ID is 00.
- Baud rate is 9600 bps.
- Check-sum is disable.

Therefore, the communication between host and the module can be easily set as the same default configuration, the initialization of a module will be possible no matter what configuration is set under operating state.

Initialization Equipment

- Host computer with an RS-232 port.
- An installed RS-485 module (NuDAM-6520) with 9600 baud rate.
- The brand new NuDAM module
- Power supply (+10 to +30 V_{DC}) for NuDAM modules
- Administration utility software

Initialization Procedure

1. Power off the host computer and the installed NuDAM-6520. Be sure of the baud rate of the NuDAM-6520 is 9600 bps.
2. Connect a brand new NuDAM module with the RS-485. Set the module in *Default State* by shorting the **DEFAULT*** pin. Refer to Figure 2.1 for detailed wiring.
3. Power on the host computer.
4. Power on the power supply for NuDAM modules.
5. Use the NuDAM Administration utility to configure the address ID, Baud rate and check-sum status of the module.

Initialization Wiring

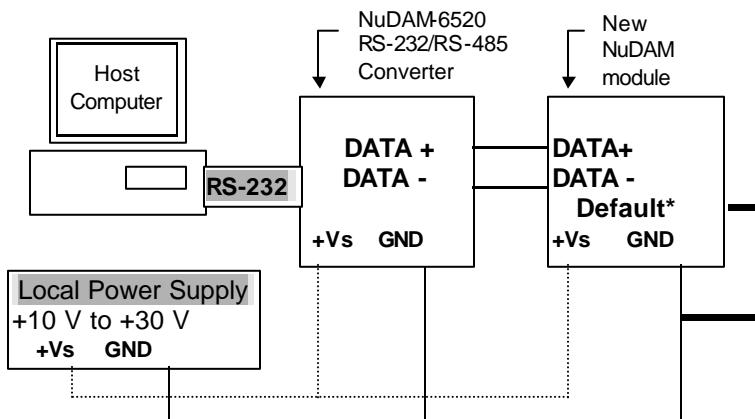

Figure 2-1 Layout for Initialization the NuDAM module

2. 3. Install a New NuDAM to a Existing Network

Equipments for Install a New Module

- A existing NuDAM network
- New NuDAM modules.
- Power supply (+10 to +30 V_{DC}).

Installing Procedures

1. Configure the new NuDAM module according to the initialization procedures in section 2.2.
2. The baud rate and check-sum status of the new module must be identity with the existing RS-485 network. The address ID must not be conflict with other NuDAM modules on the network.
3. Power off the NuDAM power supply of the existing RS-485 network.
4. Power off the host computer.
5. Wire the power lines for the new NuDAM with the existing network. Be careful about the signal polarity as wiring.
6. Wire the RS-485 data lines for the new NuDAM with the existing network. Be careful about the signal polarity as wiring.
7. Wire to the input or output devices. Refer to section 2.4 for illustrations.
8. Power on the host computer.
9. Power on the NuDAM local power supply.
10. Use the NuDAM administration utility to check entire network.

2. 4. Application Wiring for NuDAM-6080

Non-isolated Input

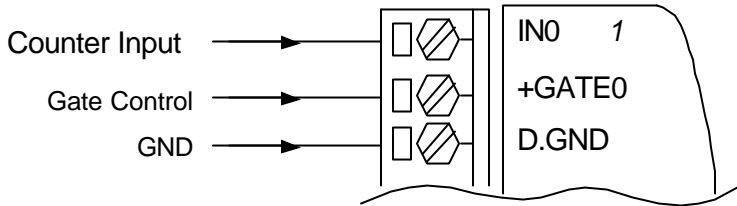
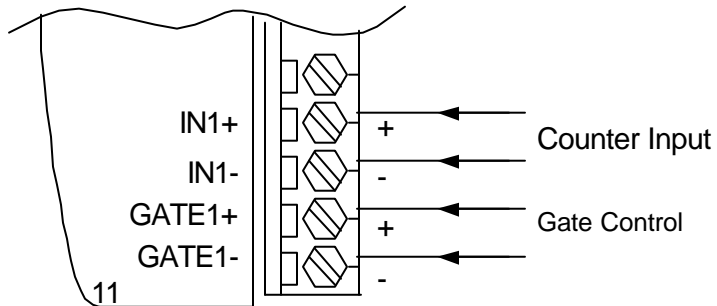

Photo-isolated Input



3. Command Set

3.1. Command and Response

Introduction

The NuDAM command is composed by numbers of characteristics, including the leading code, address ID, the variables, the optional check-sum bytes, and a carriage return to indicate the end of a command. The host computer can only command only one NuDAM module except those synchronized commands with wildcard address “***”. The NuDAM may or may not give response to the command. The host should check the response to handshake with the modules.

Document Conventions

The following syntax conventions describes the NuDAM commands in this manual.

(Leading Code)	Leading Code is the first characteristic of the NuDAM command. All NuDAM commands need a command leading code, such as %,\$,#,@,...etc. 1- character
(Addr)	Module' s address ID, the value is in the range of 00 - FF (Hex). 2- character
(Command Variable)	Command codes or value of variables. Variable length
[Data]	Some commands need additional data. Variable length
[Checksum]	Checksum in brackets indicate optional parameter, only checksum is enable then this field is required. 2- character
< >	Identifies a control code character, such as <CR> for carriage return, its value is 0x0D. 1- character

Format of NuDAM Commands

(Leading Code)(Addr)(Command)[Data][Checksum]<CR>

When checksum is enable then **[Checksum]** is needed, it is 2-character. Both command and response must append the checksum characters.

How to calculate checksum value ?

[Checksum] = ((LeadingCode)+(Addr)+(Command)+[Data]) MOD 0x100

Example 1: checksum is **disable**

```
User Command : $012<CR>
Response : !01400600<CR>
```

\$: LeadingCode
01 : Address
2 : Command (Read Configuration)
<CR> : Carriage return 0x0D

Example 2: checksum is **enable**

```
User Command : $012B7<CR>
Response : !01400600AC<CR>
```

\$: LeadingCode
01 : Address
2 : Command (Read Configuration)
B7 : Checksum value
<CR> : Carriage return 0x0D

' \$ ' = 0x24 ' 0 ' = 0x30 ' 1 ' = 0x31 ' 2 ' = 0x32

B7 = (0x24 + 0x30 + 0x31 + 0x32) MOD 0x100

'!' = 0x24 '0' = 0x30 '1' = 0x31 '4' = 0x34
'6' = 0x36

$$\text{AC} = (0x24 + 0x30 + 0x31 + 0x34 + 0x30 + 0x30 + 0x36 + 0x30 + 0x30) \text{ MOD } 0x100$$

-
- Note :
1. There is no spacing between the command words and the checksum characters.
 2. Every command follows a <CR> carriage return for ending.
 3. The checksum characters are optional.
-

Response of NuDAM Commands

The response message depends on versatile NuDAM command. The response is composed with a few characteristics, including leading code, variables, and carriage return for ending. There are two categories of leading code for response message, "!" or ">" means valid command and "?" means invalid. By checking the response message, user can monitor the command is valid or not.

-
- Note :** Under the following conditions, there will have **no response** message.
1. The specified address ID is not exist.
 2. Syntax error.
 3. Communication error.
 4. Some special commands do not have response.
-

3. 2. Summary of Command Set

There are three categories of NuDAM commands. The first is the **general commands**, including set configuration command, read configuration, reset, read module's name or firmware version, etc. Every NuDAM can response to the general commands. The second is the **functional commands**, which depends on functions of each module. Not every module can execute all function commands. The third is the **special commands** including functions about the programmable watchdog timer, safe values, and the programmable leading code. All the commands used in the NuDAM analog input module are list in the following table.

Command Set of NuDAM 6080	
Command	Syntax
Configuration, Counter Input & Display Commands	
Set Configuration	%(OldAddr)(NewAddr)(TypeCode) (BaudRate)(ChecksumFlag)
Read Configuration	\$(Addr)2
Read Module Name	\$(Addr)M
Read Firmware Version	\$(Addr)F
Set Input Signal Mode	\$(Addr)B(InType)
Read Input Signal Mode	\$(Addr)B
Read Counter/Frequency Value in Hexadecimal	\$(Addr)(CounterNo)
Read Counter/Frequency Value in Decimal	\$(Addr)(CounterNo)D

Command	Syntax
<i>Counter Setup Commands</i>	
Set Gate Mode	\$(Addr)A(Gmode)
Read Gate Mode	\$(Addr)A
Set Maximum Counter Value	\$(Addr)3(CounterNo) (MaxData)
Read Maximum Counter Value	\$(Addr)3(CounetrNo)
Set Initial Count Value	@(Addr)P(CounterNo) (IniData)
Read Initial Count Value	@(Addr)G(CounetrNo)
Start/Stop Counter	\$(Addr)5(CounterNo) (SStatus)
Read Counter Start/Stop Status	\$(Addr)5(CounterNo)
Clear Counter	\$(Addr)6(CounterNo)
Read then Clear the Overflow Flag	\$(Addr)7(CounterNo)

Command	Syntax
<i>Digital Filter & Programmable Threshold Commands</i>	
Enable/Disable Digital Filter	\$(Addr)4(FStatus)
Read Filter Status	\$(Addr)4
Set Minimum Input Signal Width at High Level	\$(Addr)0H(MinFData)
Read Minimum Input Signal Width at High Level	\$(Addr)0H
Set Minimum Input Signal Width at Low Level	\$(Addr)0L(MinFData)
Read Minimum Input Signal Width at Low Level	\$(Addr)0L
Set TTL Input High Trigger Level	\$(Addr)1H(ThData)
Read TTL Input High Trigger Level	\$(Addr)1H
Set TTL Input Low Trigger Level	\$(Addr)1L(ThData)
Read TTL Input Low Trigger Level	\$(Addr)1L

Command	Syntax
Digital Output & Alarm Commands	
Enable Alarm	@(Addr)EA(CounterNo)
Disable Alarm	@(Addr)DA(CounterNo)
Set Alarm Limit Value of Counter 0	@(Addr)PA(ArmData)
Set Alarm Limit Value of Counter 1	@(Addr)SA(ArmData)
Read Alarm Limit Value of Counter 0	@(Addr)RP
Read Alarm Limit Value of Counter 1	@(Addr)RA
Set Digital Output Values	@(Addr)DO(DoData)
Read Digital Output and Alarm Status	@(Addr)DI

Command	Syntax
Special Commands	
Read Command Leading Code Setting	~(Addr)0
Change Command Leading Code Setting	~(Addr)10(C1)(C2)(C3)(C4)(C5)(C6)
Set Host Watchdog / Safety Value	~(Addr)2(Flag)(TimeOut)(SafeValue)
Read Host WatchDog / Safe Value	~(Addr)3
Host is OK	~**

3. 3. Set Configuration

@Description

Configure the basic setting about address ID, baud rate, and checksum.

@Syntax

%(OldAddr)(NewAddr)(TypeCode)(BaudRate)(ChecksumFlag)<CR>

%	Command leading code. (1-character)
(OldAddr)	NuDAM module original address ID. The default address ID of a brand new module is 01. The value range of address ID is 00 to FF in hexadecimal. (2-character)
(NewAddr)	New address ID, if you don't want to change address ID, let new address ID equals to the old one. (2-character)
(TypeCode)	Type Code represents the input mode. (2-character) 50: counter input mode 51: frequency input mode
(BaudRate)	Communication baud rate, refer to Table 3-1 for details. (2-character)
(ChecksumFlag)	Define check-sum status and frequency gate time, refer to Table 3-2 for details. (2-character)

@Response

!(Addr)<CR>

or

?(Addr)<CR>

(Addr)	Address ID.
!	Command is valid.
?	Command is invalid. Invalid parameter values, When you wanted to change the setting without grounding the DEFAULT* pin.

Note : When you want to change the checksum or baud rate then the DEFAULT* pin should be grounded at first.

@Example

```
User command: %0130500600<CR>
Response: !30<CR>
```

Item	Meaning	Description
%	(Leading Code)	Command leading code.
01	(OldAddr)	Original address ID is 01H.
30	(NewAddr)	New address ID is 30H (Hexadecimal).
50	(TypeCode)	Counter input mode.
06	(BaudRate)	Baud rate is 9600.
00	(CheckSumFlag)	00 means checksum is disable, and frequency gate is 0.1 second.
<CR>	Carriage return	0x0D.

Code	Baudrate
03	1200 bps
04	2400 bps
05	4800 bps
06	9600 bps
07	19200 bps
08	38400 bps

Table -1 Baud rate setting code

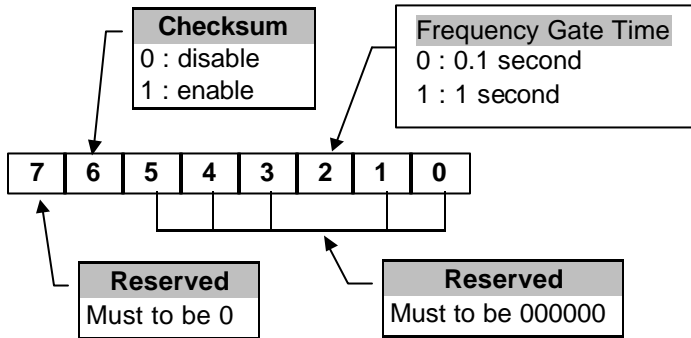

Table -2 Check sum flag setting

3. 4. Read Configuration

@Description

Read the configuration of module on a specified address ID.

@Syntax

\$(Addr)2<CR>

\$	Command leading code
(Addr)	Address ID.
2	Command code for reading configuration

@Response

!(Addr)(TypeCode)(BaudRate)(ChecksumFalg)<CR>

or

?(Addr)<CR>

!	Command is valid.
?	Command is invalid.
(Addr)	Address ID.
(TypeCode)	Input mode
(BaudRate)	Current setting of communication baud rate, refer to Table 3-1 for details.
(ChecksumFlag)	Current setting of check-sum flag, refer to Table 2. for details.

@Example

User command:	\$302<CR>
Response:	!30500600<CR>

!	Command is valid.
30	Address ID.
50	Counter Input Mode.
06	Baud rate is 9600 bps.
00	checksum is disable, frequency gate is 0.1 second.

3. 5. Read Module Name

@Description

Read NuDAM module' s name.

@Syntax

\$(Addr)M<CR>

\$	Command leading code.
(Addr)	Address ID
M	Read module name

@Response

!(Addr)(ModuleName) <CR>

or

?(Addr)<CR>

!	Command is valid.
?	Command is invalid.
(Addr)	Address ID.
(ModuleName)	NuDAM module' s name.

@Example

User command:	\$30M<CR>
Response:	!306080<CR>

!	Command is valid.
30	Address
6080	ND-6080 (Counter/Frequency module)

3. 6. Read Firmware Version

@Description

Read NuDAM module' s firmware version.

@Syntax

\$(Addr)F<CR>

\$	Command leading code.
(Addr)	Address ID
F	Read module firmware version.

@Response

!(Addr)(FirmRev) <CR>

or

?(Addr)<CR>

!	Command is valid.
?	Command is invalid.
(Addr)	Address ID.
(FirmRev)	NuDAM module' s firmware version.

@Example

User command:	\$30F<CR>
Response:	!30A1.50<CR>

!	Command is valid.
30	Address
A1.50	Firmware Version

3. 7. Set Input Mode

@Description

Set the input signal mode of counter/frequency to either TTL or photo isolated mode.

@Syntax

\$(Addr)B(InType)<CR>

\$ Command leading code.
(Addr) Address ID
B Set input mode Command
(InType) 0: TTL input
1: photo isolated input

@Response

!(Addr)<CR>

or

?(Addr)<CR>

! Command is valid.
? Command is invalid.
(Addr) Address ID.

@Example

User command: \$30B0<CR>
Response: !30<CR>

Item	Meaning	Description
\$	(Leading Code)	Command leading code.
30	(Addr)	Address ID is 30H.
B		Set Input mode.
0	(InType)	TTL input.

3. 8. Read Input Mode

@Description

Read the input signal mode of counter/frequency module.

@Syntax

\$(Addr)B<CR>

\$	Command leading code.
(Addr)	Address ID
B	Read input mode Command

@Response

!(Addr)(InType)<CR>

or

?(Addr)<CR>

!	Command is valid.
?	Command is invalid.
(Addr)	Address ID.
(InType)	0: TTL input mode. 1: Photo isolated input mode.

@Example

User command:	\$30B<CR>
Response:	!301<CR>

!	Command is valid.
30	Address
1	Photo isolated input.

3. 9. Read Counter/Frequency Value in HEX Format

@Description

Read the Counter/Frequency module of counter 0 or 1 and return the acquired data in hexadecimal format.

@Syntax

#(Addr)(CounterNo)<CR>

#	Command leading code. (1-character)
(Addr)	Address ID (2-character)
(CounterNo)	0: Counter 0. 1: Counter 1. (1-character)

@Response

>Data<CR>

or

?(Addr)<CR>

>	Command is valid
?	Command is invalid.
(Addr)	Address ID.

@Example

User command:	#300<CR>
Response:	>0000FFFF<CR>

30	Address ID
0	Read counter 0 value
0000FFFF	Return value 0x0000FFFF = 65,535

User command:	#2F1<CR>
Response:	>00001234<CR>

2F	Address ID
1	Read Counter 1 Value
00001234	Return value 0x00001234 = 4,660

3. 10. Read Counter/Frequency Value in DEC Format

@Description

Read the Counter/Frequency module of counter 0 or 1 and return the acquired data in decimal format.

@Syntax

#(Addr)(CounterNo)D<CR>

#	Command leading code. (1-character)
(Addr)	Address ID (2-character)
(CounterNo)	0: Counter 0. 1: Counter 1. (1-character)
D	Decimal command code.

@Response

>Data<CR>

or

?(Addr)<CR>

>	Command is valid
?	Command is invalid.
(Addr)	Address ID.

@Example

User command:	#300<CR>
Response:	>0000065535<CR>

30	Address ID
0	Read counter 0 value

0000065535 Return value 65535

User command:	#2F1<CR>
Response:	>0000001234<CR>

2F	Address ID
1	Read Counter 1 Value

0000001234 Return value 1234

3. 11. Set Gate Mode

@Description

Set the counter input module's gate control to either high, low or disable.

@Syntax

\$(Addr)A(Gmode)<CR>

\$ Command leading code.
(Addr) Address ID (**2-character**)
A Gate command code
(Gmode) 0: the gate is low
1: the gate is high
2: the gate is disable

@Response

!(Addr)<CR>

or

?(Addr)<CR>

! Command is valid.
? Command is invalid.
(Addr) Address ID.

@Example

User command: **\$30A0<CR>**

Response: **!30<CR>**

Item	Meaning	Description
\$	(Leading Code)	Command leading code.
30	(Addr)	Address ID is 30H.
A		Set gate mode.
0	(Gmode)	The gate is low.

3. 12. Read Gate Mode

@Description

Read the counter input module' s gate status.

@Syntax

```
$(Addr)A<CR>
```

\$ Command leading code.
(Addr) Address ID (**2-character**)
A Gate command code

@Response

```
!(Addr)(Gmode)<CR>
```

or

```
?(Addr)<CR>
```

! Command is valid.
? Command is invalid.
(Addr) Address ID.
(Gmode) 0: the gate is low
1: the gate is high
2: the gate is disable

@Example

```
User command: $30A<CR>  
Response: !301<CR>
```

Item	Meaning	Description
\$	(Leading Code)	Command leading code.
30	(Addr)	Address ID is 30H.
A		Set gate mode.

! Command is valid.
30 Address of counter/frequency module.
1 The gate is high.

3. 13. Set Maximum Counter Value

@Description

Set the maximum counter value of counter 0 or counter 1.

@Syntax

\$(Addr)3(CounterNo)(MaxData)<CR>

\$ Command leading code.
(Addr) Address ID (**2-character**)
3 Maximum counter value command.
(CounterNo) 0: counter 0
1: counter 1
(MaxData) The maximum counter value which consists of 8 hexadecimal digits. When counting value exceeds the maximum counter value, an overflow flag status will set.

@Response

!(Addr)<CR>

or

?(Addr)<CR>

! Command is valid.
? Command is invalid.
(Addr) Address ID.

@Example

User command: \$303000010000<CR>

Response: !30<CR>

Item	Meaning	Description
\$	(Leading Code)	Command leading code.
30	(Addr)	Address ID is 30H.
3		Set maximum counter value.
0	(CounterNo)	Counter 0.
0001000 0	(MaxData)	65536(0x00010000)

3. 14. Read Maximum Counter Value

@Description

Read the maximum counter value of counter 0 or counter 1.

@Syntax

\$(Addr)3(CounterNo)<CR>

\$ Command leading code.
(Addr) Address ID (**2-character**)
3 Maximum counter value command code
(CounterNo) 0: counter 0
1: counter 1

@Response

!(Addr)(MaxData)<CR>

or

?(Addr)<CR>

! Command is valid.
? Command is invalid.
(Addr) Address ID.
(MaxData) The maximum counter value which consists of 8 hexadecimal digits.

@Example

User command: \$3031<CR>
Response: !3000001234<CR>

Item	Meaning	Description
\$	(Leading Code)	Command leading code.
30	(Addr)	Address ID is 30H.
3		Read maximum counter value.
1	(CounterNo)	Counter 1.

! Command is valid.
30 Address of counter/frequency module.
00001234 4660(0x00001234).

3. 15. Set Initial Count Value

@Description

Set the initial count value of counter 0 or counter 1.

@Syntax

\$(Addr)P(CounterNo)(IniData)<CR>

\$ Command leading code.
(Addr) Address ID (**2-character**)
P Set initial count value command code.
(CounterNo) 0: counter 0
1: counter 1
(IniData) The initial count value which consists of 8 hexadecimal digits.

@Response

!(Addr)<CR>

or

?(Addr)<CR>

! Command is valid.
? Command is invalid.
(Addr) Address ID.

@Example

User command: **\$30P000000100<CR>**

Response: **!30<CR>**

Item	Meaning	Description
\$	(Leading Code)	Command leading code.
30	(Addr)	Address ID is 30H.
P		Set initial count value.
0	(CounterNo)	Counter 0.
00000100	(IniData)	256(0x00000100)

3. 16. Read Initial Count Value

@Description

Read the initial count value of counter 0 or counter 1.

@Syntax

\$(Addr)G(CounterNo)<CR>

\$ Command leading code.
(Addr) Address ID (**2-character**)
G Read initial counter value command code
(CounterNo) 0: counter 0
1: counter 1

@Response

!(Addr)(IniData)<CR>

or

?(Addr)<CR>

! Command is valid.
? Command is invalid.
(Addr) Address ID.
(IniData) The initial count value which consists of 8 hexadecimal digits.

@Example

User command: **\$30G1<CR>**
Response: **!30000000FF<CR>**

Item	Meaning	Description
\$	(Leading Code)	Command leading code.
30	(Addr)	Address ID is 30H.
G		Read initial count value.
1	(CounterNo)	Counter 1.

! Command is valid.
30 Address of counter/frequency module.
000000FF 255(0x000000FF).

3. 17. Start/Stop Counter

@Description

Start or stop counting of counter 0 or counter 1.

@Syntax

`$(Addr)5(CounterNo)(SStatus)<CR>`

\$ Command leading code.
(Addr) Address ID (**2-character**)
5 Start/stop counter command code.
(CounterNo) 0: counter 0
1: counter 1
(SStatus) 0: stop counting
1: start counting

@Response

`!(Addr)<CR>`

or

`?(Addr)<CR>`

! Command is valid.
? Command is invalid.
(Addr) Address ID.

@Example

User command: `$30501<CR>`

Response: `!30<CR>`

Item	Meaning	Description
\$	(Leading Code)	Command leading code.
30	(Addr)	Address ID is 30H.
5		Start/stop counting command.
0	(CounterNo)	Counter 0.
1	(SStatus)	Start counting.

3. 18. Read Start/Stop Counter Status

@Description

Read the status of counter 0 or counter 1 for its active or inactive condition.

@Syntax

```
$(Addr)5(CounterNo)<CR>
```

\$	Command leading code.
(Addr)	Address ID (2-character)
5	Start/stop counter command code.
(CounterNo)	0: counter 0 1: counter 1

@Response

```
!(Addr)(SStatus)<CR>
```

or

```
?(Addr)<CR>
```

!	Command is valid.
?	Command is invalid.
(Addr)	Address ID.
(Sstatus)	0: stop counting 1: start counting

@Example

```
User command: $3050<CR>  
Response: !301<CR>
```

!	Command is valid.
30	Address of counter/frequency module.
1	Counter 0 is counting.

3. 19. Clear Counter

@Description

Clear the value of counter 0 or counter 1.

@Syntax

\$(Addr)6(CounterNo)<CR>

\$ Command leading code.
(Addr) Address ID (**2-character**)
6 Clear counter command code.
(CounterNo) 0: counter 0
1: counter 1

@Response

!(Addr)<CR>

or

?(Addr)<CR>

! Command is valid.
? Command is invalid.
(Addr) Address ID.

@Example

User command: \$3060<CR>

Response: !30<CR>

Item	Meaning	Description
\$	(Leading Code)	Command leading code.
30	(Addr)	Address ID is 30H.
6		Clear counter command code.
0	(CounterNo)	Counter 0.

3. 20. Read then Clear Overflow Flag

@Description

Read the status of the overflow flag of counter 0 or counter 1, and then clear the flag afterward.

@Syntax

\$(Addr)7(CounterNo)<CR>

\$	Command leading code.
(Addr)	Address ID (2-character)
7	Read then clear overflow command code.
(CounterNo)	0: counter 0 1: counter 1

@Response

!(Addr)(OFlag)<CR>

or

?(Addr)<CR>

!	Command is valid.
?	Command is invalid.
(Addr)	Address ID.
(OFlag)	0: the overflow flag has not been set 1: the counting value has exceeded the maximum count, the overflow flag has been set.

*** After executing the command, the overflow flag will clear to zero if it has been set.**

@Example

User command: \$3070<CR>
Response: !301<CR>

Item	Meaning	Description
\$	(Leading Code)	Command leading code.
30	(Addr)	Address ID is 30H.
7		Read counter overflow command code.
0	(CounterNo)	Counter 0.

! Command is valid.
30 Address of counter/frequency module.
1 Counter 0 is overflowed.

3. 21. Enable/Disable Digital Filter

@Description

Enable or disable the digital filter function.

@Syntax

```
$(Addr)4(FStatus)<CR>
```

\$ Command leading code.
(Addr) Address ID (**2-character**)
4 Enable/Disable filter command code.
(FStatus) 0: disable filter
1: enable filter

@Response

```
!(Addr)<CR>
```

or

```
?(Addr)<CR>
```

! Command is valid.
? Command is invalid.
(Addr) Address ID.

@Example

```
User command: $3040<CR>
```

```
Response: !30<CR>
```

Item	Meaning	Description
\$	(Leading Code)	Command leading code.
30	(Addr)	Address ID is 30H.
4		Enable/Disable filter command.
0	(FStatus)	Disable filter.

3. 22. Read Filter Status

@Description

Read the digital filter enable/disable status.

@Syntax

\$(Addr)4<CR>

\$ Command leading code.
(Addr) Address ID (**2-character**)
4 Enable/Disable filter command code.

@Response

!(Addr)(FStatus)<CR>

or

?(Addr)<CR>

! Command is valid.
? Command is invalid.
(Addr) Address ID.
(FStatus) 0: disable filter
1: enable filter

@Example

User command: \$304<CR>
Response: !301<CR>

Item	Meaning	Description
\$	(Leading Code)	Command leading code.
30	(Addr)	Address ID is 30H.
4		Enable/Disable filter command.

! Command is valid.
30 Address of counter/frequency module.
1 Digital filter is enable.

3. 23. Set Minimum Input Signal Width at High Level

@Description

Set the minimum input signal width at high level, for signal level high less then this value will be filtered out as noise.

@Syntax

\$(Addr)0H(MinFData)<CR>

\$ Command leading code.
(Addr) Address ID (**2-character**)
0H Set minimum input signal width at high level command code.
(MinFData) The minimum width data at high level. The unit is μs and its resolution is $1 \mu\text{s}$. This value range from $4 \mu\text{s}$ to $1020 \mu\text{s}$, which is a 4-digit integer. (**4-character**)

@Response

!(Addr)<CR>

or

?(Addr)<CR>

! Command is valid.
? Command is invalid.
(Addr) Address ID.

@Example

User command: **\$30H0100<CR>**

Response: **!30<CR>**

Item	Meaning	Description
\$	(Leading Code)	Command leading code.
30	(Addr)	Address ID is 30H.
0H		Set minimum input signal width.
0100	(MinFData)	$100 \mu\text{s}$

3. 24. Read Minimum Input Signal Width at High Level

@Description

Read the minimum input signal width at high level.

@Syntax

\$(Addr)0H<CR>

\$ Command leading code.
(Addr) Address ID (**2-character**)
0H Set minimum input signal width at high level command code.

@Response

!(Addr)(MinFData)<CR>

or

?(Addr)<CR>

! Command is valid.
? Command is invalid.
(Addr) Address ID.
(MinFData) The minimum width data at high level. The unit is μs and its resolution is $1 \mu\text{s}$. This value range from $4 \mu\text{s}$ to $1020 \mu\text{s}$, which is a 4-digit integer.

@Example

User command: **\$300H<CR>**
Response: **!300100<CR>**

Item	Meaning	Description
\$	(Leading Code)	Command leading code.
30	(Addr)	Address ID is 30H.
0H		Set minimum input signal width.

! Command is valid.
30 Address of counter/frequency module.
0100 Digital filter value of minimum signal width at high level is $100 \mu\text{s}$.

3. 25. Set Minimum Input Signal Width at Low Level

@Description

Set the minimum input signal width at low level, for signal level low less then this value will be filtered out as noise.

@Syntax

```
$(Addr)0L(MinFData)<CR>
```

\$ Command leading code.
(Addr) Address ID (**2-character**)
0L Set minimum input signal width at low level command code.
(MinFData) The minimum width data at low level. The unit is μs and its resolution is $1 \mu\text{s}$. This value range from $4 \mu\text{s}$ to $1020 \mu\text{s}$, which is a 4-digit integer. (**4-character**)

@Response

```
!(Addr)<CR>
```

or

```
?(Addr)<CR>
```

! Command is valid.
? Command is invalid.
(Addr) Address ID.

@Example

```
User command: $300L0010<CR>
```

```
Response: !30<CR>
```

Item	Meaning	Description
\$	(Leading Code)	Command leading code.
30	(Addr)	Address ID is 30H.
0L		Set minimum input signal width.
0010	(MinFData)	$10 \mu\text{s}$

3. 26. Read Minimum Input Signal Width at Low Level

@Description

Read the minimum input signal width at low level.

@Syntax

\$(Addr)0L<CR>

\$ Command leading code.
(Addr) Address ID (**2-character**)
0L Set minimum input signal width at low level command code.

@Response

!(Addr)(MinFData)<CR>

or

?(Addr)<CR>

! Command is valid.
? Command is invalid.
(Addr) Address ID.
(MinFData) The minimum width data at low level. The unit is μs and its resolution is $1 \mu\text{s}$. This value range from $4 \mu\text{s}$ to $1020 \mu\text{s}$, which is a 4-digit integer.

@Example

User command: **\$300L<CR>**
Response: **!300010<CR>**

Item	Meaning	Description
\$	(Leading Code)	Command leading code.
30	(Addr)	Address ID is 30H.
0L		Set minimum input signal width.

! Command is valid.
30 Address of counter/frequency module.
0010 Digital filter value of minimum signal width at low level is $10 \mu\text{s}$.

3. 27. Set TTL Input High Trigger Level

@Description

Set the TTL input high trigger level, for voltage level higher than this value is recognized as logic high.

@Syntax

\$(Addr)1H(ThData)<CR>

\$ Command leading code.
(Addr) Address ID (**2-character**)
1H TTL input high trigger level command code.
(ThData) The high trigger level for TTL input. The unit is 0.1 V and its resolution is 0.1 V too. This value range from 0.1 to 5V, which is a 2-digit integer.

@Response

!(Addr)<CR>

or

?(Addr)<CR>

! Command is valid.
? Command is invalid.
(Addr) Address ID.

@Example

User command: \$301H30<CR>
Response: !30<CR>

Item	Meaning	Description
\$	(Leading Code)	Command leading code.
30	(Addr)	Address ID is 30H.
1H		Set TTL input high trigger level.
30	(ThData)	3 V

3. 28. Read TTL Input High Trigger Level

@Description

Read the TTL input high trigger level.

@Syntax

\$(Addr)1H<CR>

\$ Command leading code.
(Addr) Address ID (**2-character**)
1H TTL input high trigger level command code.

@Response

!(Addr)(ThData)<CR>

or

?(Addr)<CR>

! Command is valid.
? Command is invalid.
(Addr) Address ID.
(ThData) The high trigger level for TTL input. The unit is 0.1 V and its resolution is 0.1 V too. This value range from 0.1 to 5V, which is a 2-digit integer.

@Example

User command: **\$301H<CR>**

Response: **!3024<CR>**

Item	Meaning	Description
\$	(Leading Code)	Command leading code.
30	(Addr)	Address ID is 30H.
1H		Read TTL input high trigger level.

! Command is valid.
30 Address of counter/frequency module.
24 The high trigger level is 2.4 V.

3. 29. Set TTL Input Low Trigger Level

@Description

Set the TTL input low trigger level, for voltage level lower than this value is recognized as logic low.

@Syntax

\$(Addr)1L(ThData)<CR>

\$ Command leading code.
(Addr) Address ID (**2-character**)
1L TTL input low trigger level command code.
(ThData) The low trigger level for TTL input. The unit is 0.1 V and its resolution is 0.1 V too. This value range from 0.1 to 5V, which is a 2-digit integer.

@Response

!(Addr)<CR>

or

?(Addr)<CR>

! Command is valid.
? Command is invalid.
(Addr) Address ID.

@Example

User command: \$301L10<CR>
Response: !30<CR>

Item	Meaning	Description
\$	(Leading Code)	Command leading code.
30	(Addr)	Address ID is 30H.
1L		Set TTL input low trigger level.
10	(ThData)	1 V

3. 30. Read TTL Input Low Trigger Level

@Description

Read the TTL input low trigger level.

@Syntax

\$(Addr)1L<CR>

\$ Command leading code.
(Addr) Address ID (**2-character**)
1L TTL input low trigger level command code.

@Response

!(Addr)(ThData)<CR>

or

?(Addr)<CR>

! Command is valid.
? Command is invalid.
(Addr) Address ID.
(ThData) The high trigger level for TTL input. The unit is 0.1 V and its resolution is 0.1 V too. This value range from 0.1 to 5V, which is a 2-digit integer.

@Example

User command: **\$301L<CR>**

Response: **!3008<CR>**

Item	Meaning	Description
\$	(Leading Code)	Command leading code.
30	(Addr)	Address ID is 30H.
1L		Read TTL input low trigger level.

! Command is valid.
30 Address of counter/frequency module.
08 The low trigger level is 0.8 V.

3. 31. Enable Alarm

@Description

Enables alarm function of counter 0 or counter 1. The digital output will assert if the counter value reaches the alarm limit while the alarm is enable.

@Syntax

@(Addr)EA(CounterNo)<CR>

@ Command leading code.
(Addr) Address ID (**2-character**)
EA Enable alarm command code.
(CounterNo 0: counter 0
) 1: counter 1

@Response

!(Addr)<CR>

or

?(Addr)<CR>

! Command is valid.
? Command is invalid.
(Addr) Address ID.

@Example

User command: @30EA0<CR>
Response: !30<CR>

Item	Meaning	Description
@	(Leading Code)	Command leading code.
30	(Addr)	Address ID is 30H.
EA		Enable alarm command code.
0	(CounterNo)	Counter 0.

3. 32. Disable Alarm

@Description

Disables alarm function of counter 0 or counter 1.

@Syntax

@(Addr)DA(CounterNo)<CR>

@ Command leading code.
(Addr) Address ID (**2-character**)
DA Enable alarm command code.
(CounterNo) 0: counter 0
1: counter 1

@Response

!(Addr)<CR>

or

?(Addr)<CR>

! Command is valid.
? Command is invalid.
(Addr) Address ID.

@Example

User command: @30DA0<CR>

Response: !30<CR>

Item	Meaning	Description
@	(Leading Code)	Command leading code.
30	(Addr)	Address ID is 30H.
DA		Disable alarm command code.
0	(CounterNo)	Counter 0.

3. 33. Set Alarm Limit Value of Counter 0

@Description

Set the alarm limit value of counter 0.

@Syntax

@(Addr)PA(ArmData)<CR>

@ Command leading code.
(Addr) Address ID (**2-character**)
PA Set alarm limit value command code.
(ArmData) The alarm limit value which consists of 8 hexadecimal digits.

@Response

!(Addr)<CR>

or

?(Addr)<CR>

! Command is valid.
? Command is invalid.
(Addr) Address ID.

@Example

User command: @30PA00020000<CR>

Response: !30<CR>

Item	Meaning	Description
@	(Leading Code)	Command leading code.
30	(Addr)	Address ID is 30H.
PA		Set alarm limit value of counter 0.
00020000	(ArmData)	131072(0x00020000)

3. 34. Set Alarm Limit Value of Counter 1

@Description

Set the alarm limit value of counter 1.

@Syntax

```
@(Addr)SA(ArmData)<CR>
```

@ Command leading code.
(Addr) Address ID (**2-character**)
SA Set alarm limit value command code.
(ArmData) The alarm limit value which consists of 8 hexadecimal digits.

@Response

```
!(Addr)<CR>
```

or

```
?(Addr)<CR>
```

! Command is valid.
? Command is invalid.
(Addr) Address ID.

@Example

```
User command: @30SA0002FFFF<CR>
```

```
Response: !30<CR>
```

Item	Meaning	Description
@	(Leading Code)	Command leading code.
30	(Addr)	Address ID is 30H.
SA		Set alarm limit value of counter 1.
0002FFFF	(ArmData)	196607(0x0002FFFF)

3. 35. Read Alarm Limit Value of Counter 0

@Description

Read the alarm limit value of counter 0.

@Syntax

@(Addr)RP<CR>

@ Command leading code.
(Addr) Address ID (**2-character**)
RP Read alarm limit value command code

@Response

!(Addr)(ArmData)<CR>

or

?(Addr)<CR>

! Command is valid.
? Command is invalid.
(Addr) Address ID.
(ArmData) The alarm limit value which consists of 8 hexadecimal digits.

@Example

User command: @30RP<CR>
Response: !300000FFFF<CR>

Item	Meaning	Description
@	(Leading Code)	Command leading code.
30	(Addr)	Address ID is 30H.
RP		Read alarm limit value of counter 0.

! Command is valid.
30 Address of counter/frequency module.
0000FFFF 65535(0x0000FFFF).

3. 36. Read Alarm Limit Value of Counter 1

@Description

Read the alarm limit value of counter 1.

@Syntax

@(Addr)RA<CR>

@ Command leading code.
(Addr) Address ID (**2-character**)
RA Read alarm limit value command code

@Response

!(Addr)(ArmData)<CR>

or

?(Addr)<CR>

! Command is valid.
? Command is invalid.
(Addr) Address ID.
(ArmData) The alarm limit value which consists of 8 hexadecimal digits.

@Example

User command: @30RA<CR>
Response: !300001FFFF<CR>

Item	Meaning	Description
@	(Leading Code)	Command leading code.
30	(Addr)	Address ID is 30H.
RA		Read alarm limit value of counter 0.

! Command is valid.
30 Address of counter/frequency module.
0001FFFF 131071(0x0001FFFF).

3. 37. Set Digital Output Values

@Description

Set the value (ON or OFF) of the 2 channel digital outputs.

@Syntax

@(Addr)DO(DoData)<CR>

@ Command leading code.
(Addr) Address ID
DO Set digital data output command code.
(DoData) 00: DO0 is OFF, DO1 is OFF
01: DO0 is ON, DO1 is OFF
02: DO0 is OFF, DO1 is ON
03: DO0 is ON, DO1 is ON

@Response

!(Addr)<CR>

or

?(Addr)<CR>

! Command is valid.
? Command is invalid.
(Addr) Address ID.

@Example

User command: @30DO01<CR>

Response: !30<CR>

Item	Meaning	Description
@	(Leading Code)	Command leading code.
30	(Addr)	Address ID is 30H.
DO		Set digital data output.
01	(D0Data)	DO0 is ON, DO1 is OFF

3. 38. Read Digital Output and Alarm Status

@Description

Read the current digital output channel values and the status of alarm function.

@Syntax

@(Addr)DI<CR>

@	Command leading code.
(Addr)	Address ID
DI	Read digital data output and alarm status command code.

@Response

!(Addr)(AStatus)(DoData)00<CR>

or

?(Addr)<CR>

!	Command is valid.
?	Command is invalid.
(Addr)	Address ID.
(AStatus)	0: counter 0 alarm is disabled, counter 1 alarm is disabled. 1: counter 0 alarm is enabled, counter 1 alarm is disabled. 2: counter 0 alarm is disabled, counter 1 alarm is enabled. 3: counter 0 alarm is enabled, counter 1 alarm is enabled.
(DoData)	00: DO0 is OFF, DO1 is OFF 01: DO0 is ON, DO1 is OFF 02: DO0 is OFF, DO1 is ON 03: DO0 is ON, DO1 is ON

@Example

User command: @30DI<CR>
Response: !3030200<CR>

Item	Meaning	Description
@	(Leading Code)	Command leading code.
30	(Addr)	Address ID is 30H.
DI		Set digital data output.

! Command is valid.
30 Address of counter/frequency module.
3 Counter 0 alarm is enabled, counter 1 alarm is enabled.
02 DO0 is OFF, DO1 is ON.

3. 39. Read Command Leading Code Setting

@Description

Read command leading code setting and host watchdog status.

@Syntax

`~(Addr)0<CR>`

~ Command leading code.
(Addr) Address ID
0 Read command leading code setting.

@Response

`!(Addr)(Status)(C1)(C2)(C3)(C4)(C5)(C6)<CR>`

or

`?(Addr)<CR>`

! Command is valid.
? Command is invalid.
(Addr) Address ID
(Status) **(2-character)**
Bit 0 : Reserved
Bit 1 : Power failure or watchdog failure
Bit 2 : Host watchdog is enable
Bit 3 : Host failure
(C1) Leading code 1, for read configuration status, firmware version, etc. default is \$. **(1-character)**
(C2) Leading code 2, for read synchronize sampling, digital output ,default is #. **(1-character)**
(C3) Leading code 3, for change configuration. default is %. **(1-character)**
(C4) Leading code 4, for read alarm status, enable alarm, etc. default is @. **(1-character)**
(C5) Leading code 5, for read command leading code, change command leading code, etc. default is ~. **(1-character)**
(C6) Leading code 6, this leading code is reserved. default is *. **(1-character)**

@Example

```
User command: ~060<CR>  
Response: !0600$#%@~*<CR>
```

Command leading code setting is \$#%@~* for module address ID is 06, current status is factory default setting.

3. 40. Change Command Leading Code Setting

@Description

User can use this command to change command leading code setting as he desired.

@Syntax

```
~(Addr)10(C1)(C2)(C3)(C4)(C5)(C6)<CR>
```

~	Command leading code.
(Addr)	Address ID, range (00 - FF).
10	Change command leading code setting.
(C1)	Leading code 1, for read configuration status, firmware version, etc. default is \$. (1-character)
(C2)	Leading code 2, for read synchronize sampling, digital output , default is #. (1-character)
(C3)	Leading code 3, for change configuration. default is %. (1-character)
(C4)	Leading code 4, for read alarm status, enable alarm, etc. default is @. (1-character)
(C5)	Leading code 5, for read command leading code, change leading code, etc. default is ~. (1-character)
(C6)	Leading code 6, this leading code is reserved. default is *. (1-character)

@Response

```
!(Addr)< CR>
```

or

```
?(Addr)<CR>
```

!	Command is valid.
?	Command is invalid.
(Addr)	Address ID.

@Examples

```
User command: ~060<CR>
Response: !0600$#%@~*<CR>

User command: ~0610A#%@~*<CR>
Response: !06<CR>

User command: A06F
Response: !06A1.8<CR>
```

Read leading code setting is \$#%@~* for module address 06 and change leading code \$ to A, then use A06F to read firmware version of module on address 06.

*** WARNING ***

- We do not recommend users to change the default setting of leading code, because it will make you confuse
- The leading code change only use the command conflicts other devices on the network.

3. 41. Set Host Watchdog Timer & Safety Value

@Description

Set host watchdog timer, module will change to safety state when host is failure. Define the output value in this command.

@Syntax

~(Addr)2(Flag)(TimeOut)(SafeValue)<CR>

~	Command leading code.
(Addr)	Address ID, range (00 - FF).
2	Set host watchdog timer and safe state value.
(Flag)	0 : Disable host watchdog timer 1 : Enable host watchdog timer (1-character)
(TimeOut)	Host timeout value, between this time period host must send (Host is OK) command to module, otherwise module will change to safety state. Range 01 - FF. (2-character) One unit is 53.3 ms (Firmware version 1.x) 01 = 1 * 53.3 = 53.3 ms FF = 255 * 53.3 = 13.6 sec One unit is 100 ms (Firmware version 2.x) 01 = 1 * 100 = 100 ms FF = 255 * 100 = 25.5 sec
(SafeValue)	8 channels safety value of digital output channels when host is failure. (2-character)

@Response

!(Addr)<CR>

or

?(Addr)<CR>

!	Command is valid.
?	Command is invalid.
(Addr)	Address ID

@Example

```
User command: ~0621121C<CR>
Response: !06<CR>
```

06 Address ID
2 Set host watchdog timer and safe state value.
1 Enable host watchdog timer.
12 Timeout value. $0x12 = 18$
 $18 * 53.3 = 959$ ms (Firmware Version 1.x)
 $18 * 100 = 1800$ ms (Firmware Version 2.x)
1C 1C (00011100) Digital output channel DO3, DO4
and DO5 are high, the others are low.

3. 42. Read Host Watchdog Timer & Safety Value

@Description

Read host watchdog timer setting and the safety value.

@Syntax

~(Addr)3<CR>

~	Command leading code.
(Addr)	Address ID
3	Read host watchdog setting and module safety state value.

@Response

!(Addr)(Flag)(TimeOut)(SafeValue)<CR>

or

?(Addr)<CR>

!	Command is valid.
?	Command is invalid.
(Addr)	Address ID, range (00 - FF).
(Flag)	0 : Host watchdog timer is disable 1 : Host watchdog timer is enable(1-character)
(TimeOut)	Host timeout value. Range 01 - FF. (2-character) One unit is 53.3 ms (Firmware version 1.x) 01 = 1 * 53.3 = 53.3 ms FF = 255 * 53.3 = 13.6 sec One unit is 100 ms (Firmware version 2.x) 01 = 1 * 100 = 100 ms FF = 255 * 100 = 25.5 sec
(SafeValue)	8 channels safety state digital output value when host is failure. (2-character)

@Example

```
User command: ~063<CR>
Response:     !061121C<CR>
```

06 Address ID
1 Host watchdog timer is enable.
12 Timeout value. $0x12 = 18$
 $18 * 53.3 = 959$ ms (Firmware Version 1.x)
 $18 * 100 = 1800$ ms (Firmware Version 2.x)
1C 1C (00011100) Digital output channel DO3, DO4 and DO5 are high, the others are low.

Between 959 ms (Fireware Version 1.x) or 1800 ms (Fireware Version 2.x) time period, if host does not send (Host is OK) then digital output will change to safety state 1C (00011100) means digital output DO3 , DO4 and DO5 is high, others are low.

3. 43. Host is OK

@Description

When host watchdog timer is enable, host computer must send this command to every module before timeout otherwise “**host watchdog timer enable**” module’s output value will go to safety state output value.

Timeout value and safety state output value is defined in 3.14.
“Set Host Watchdog Timer & Safety Value”

@Syntax

```
~**<CR>
```

~ Command leading code.
** Host is OK.

@Response

Note : Host is OK command **has NO response**.

@Example

```
User command:        ~**<CR>
```