

Service Manual

SDG5000 Series

Function/Arbitrary Waveform Generator

Guaranty and Declaration

Copyright

SIGLENT TECHNOLOGIES CO., LTD. All Rights Reserved.

Trademark Information

SIGLENT is the registered trademark of SIGLENT TECHNOLOGIES CO., LTD

Declaration

- **SIGLENT** products are protected by patent law in and outside of P.R.C.
- **SIGLENT** reserves the right to modify or change parts of or all the specifications or pricing policies at company's sole decision.
- Information in this publication replaces all previously corresponding material.
- Any way of copying, extracting or translating the contents of this manual is not allowed without the permission of **SIGLENT**.
- **SIGLENT** will not be responsible for losses caused by either incidental or consequential in connection with the furnishing, use or performance of this manual as well as any information contained.

Product Certification

SIGLENT guarantees this product conforms to the national and industrial standards in china as well as the ISO9001: 2008 standard and the ISO14001: 2004 standard. Other international standard conformance certification is in progress.

General Safety Summary

Carefully read the following safety precautions to avoid person injury and prevent damage to the instrument or any products connected to it. To avoid potential hazards, please use the instrument as specified.

Only qualified technician should perform service procedures

Use Proper Power Line

Use only the special power line of the instrument that approved by local state.

Ground the Instrument

The instrument grounds through the protective terra conductor of the power line. To avoid electric shock, the ground conductor must be connected to the earth. Make sure the instrument is grounded correctly before connect its input or output terminals.

Connect the Signal Wire correctly

The potential of the signal wire is equal to the earth, so do not connect the signal wire to a high voltage. Do not touch the exposed contacts or components.

Look Over All Terminals' Ratings

To avoid fire or electric shock, please look over all ratings and sign instruction of the instrument. Before connecting the instrument, please read the manual carefully to gain more information about the ratings.

Not Operate with Suspected Failures

If you suspect that there is a damage of the instrument, please let a qualified service personnel check it.

Avoid Circuit or Components Exposed

Do not touch exposed contacts or components when the power is on.

Do not operate in Wet/Damp conditions

Do not operate in an Explosive atmosphere

Keep the surface of the instrument Clean and Dry

Safety Terms and Symbols

Terms used on the instrument. Terms may appear on the instrument:

DANGER: Indicates an injury or hazard that may immediately happen.

WARNING: Indicates an injury or hazard that may not immediately happen.

CAUTION: Indicates a potential damage to the instrument or other property that might occur.

Symbols used on the instrument. Symbols may appear on the instrument:

				
Hazardous Voltage	Protective Earth Ground	Warning	Earth Ground	Power Switch

Overview for the Document

The document is for SDG5000 series arbitrary waveform generator, which will be mostly written as generator for short in the following text. The main contents described in this manual are:

SDG5000 Series Generator at a glance

This part introduces the main technology characteristics for SDG5000 generator.

The Front Panel at a glance

This part introduces briefly all the buttons and the knob on the front panel.

The Rear Panel at a glance

This part introduces all the ports for easy communication on the rear panel.

Specifications

Chapter 1 lists the generator's specifications.

Quick Start

Chapter 2 prepares the generator for use and helps you get familiar with a few of its front-panel features.

Calibration

Chapter 3 provides calibration, verification and adjustment procedures for the generator.

Assembly Procedures

Chapter 4 provides disassembly procedures for you to get an understanding of the structure of the generator, thus to install or replace some needed modules, or troubleshoot faults you encounter while operating it.

Troubleshooting

Chapter 5 provides troubleshooting procedures for the internal main board and power supply board, as well as the quick guide for general troubles. Before any operation, you should read the ESD Precautions to avoid personal injuries or damages to the generator

Maintainance

Chapter 6 provides information on maintenance, daily care and unpacking inspection of the instrument. The contact information is attached in the end in case of some unsolvable troubles you encounter.

Convention for the whole Contents

All the description for function and performance in this document are according to SDG5162 series generator, and apply to generator of the other types. The SDS5000 series contains the following types:

Type	Analog Bandwith	Channel
SDG5082	80 MHz	2
SDG5122	120 MHz	2
SDG5162	160 MHz	2

SDG5000 Series at a Glance

SDG5000 Series adopt the direct digital synthesis (DDS) technology, which can provide stable, high-precision, pure and low distortion signals. Its combination of excellent system features, easiness in usage and versatile functions makes this generator a perfect solution for your testing now and in the future.

Characteristics

Reading the characteristics and specifications given below, you will understand how SDG5000 can satisfy your requirements.

- DDS technology provides precise, stable and low distortional output signal.
- 4.3inch'TFT color LCD display.
- 500MSa/s sampling rate, 14-bit resolution.
- Frequency characteristics:
 - Sine: 1 μ Hz to 160 MHz
 - Square: 1 μ Hz to 50 MHz
 - Ramp: 1 μ Hz to 4MHz
 - Pulse: 1 μ Hz to 40MHz
 - White Noise: 100MHz bandwidth (-3dB)
 - Arbitrary: 1 μ Hz to 40MHz
- 5 standard waveforms: Sine, Square, Ramp, Pulse, Noise.
- Self-defined arbitrary waveform.
- Multiple modulation function, various modulated waveform: AM, DSB-AM, FM, PM, ASK, FSK, PWM, Sweep and Burst.
- Multiple I/O: external modulation source, external 10 MHz reference input, external trigger source, waveform output, synchronous signal output.
- Support USB storage device. Software updating could also be performed using USB devices.
- Up to 512k sample points of internal waveform depth, which can rebuild or

simulate any complex waveform.

- Remote control is realized using the USB cable.
- Multiple interfaces: USB host & device. USB-GPIB (IEEE-488) and LAN (option).
- Support the seamless connection with SIGLENT Series Digital Oscilloscopes; Being able to directly read and rebuild the stored waveform in the oscilloscopes.
- 2 languages (English and Chinese) user interface and built-in help system.

Note: *All the specifications described in this manual are according to SDG5162.*

The Front Panel at a Glance

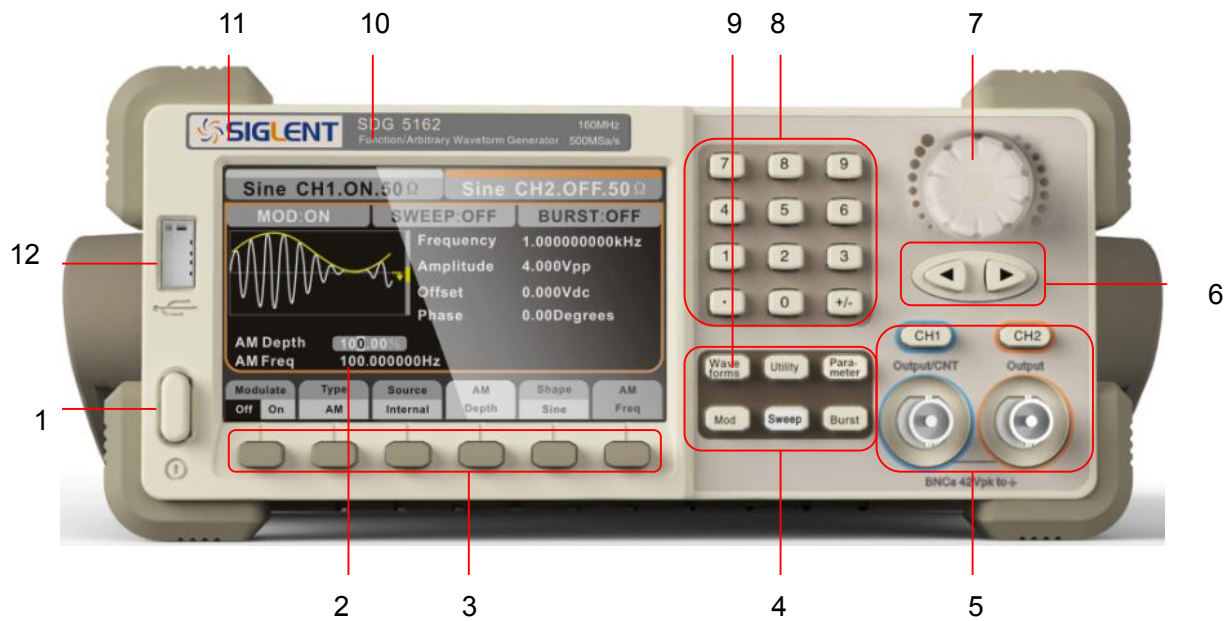

No.	Description	No.	Description
1	Power Switch	7	Universal Knob
2	LCD Display	8	Numeric Keypad
3	Menu Operation	9	Waveform Key
4	Function Keys	10	Type
5	Output Control	11	Logo
6	Direction Keys	12	USB Host

The Front Panel Display at a Glance

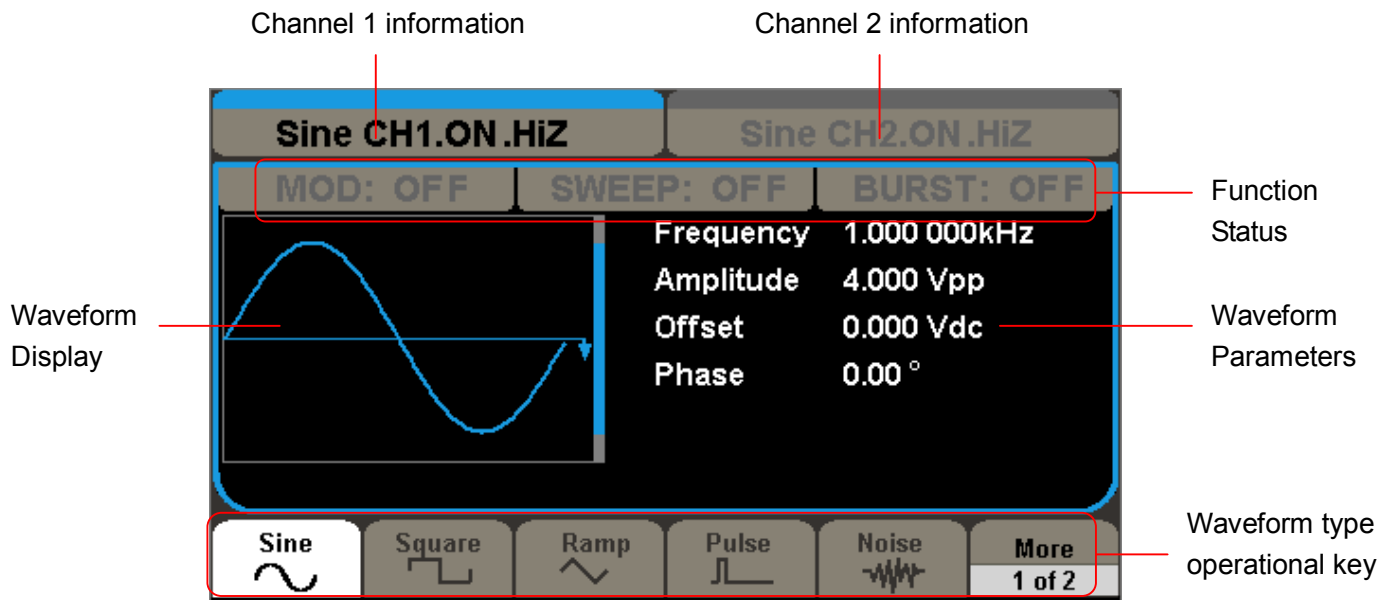
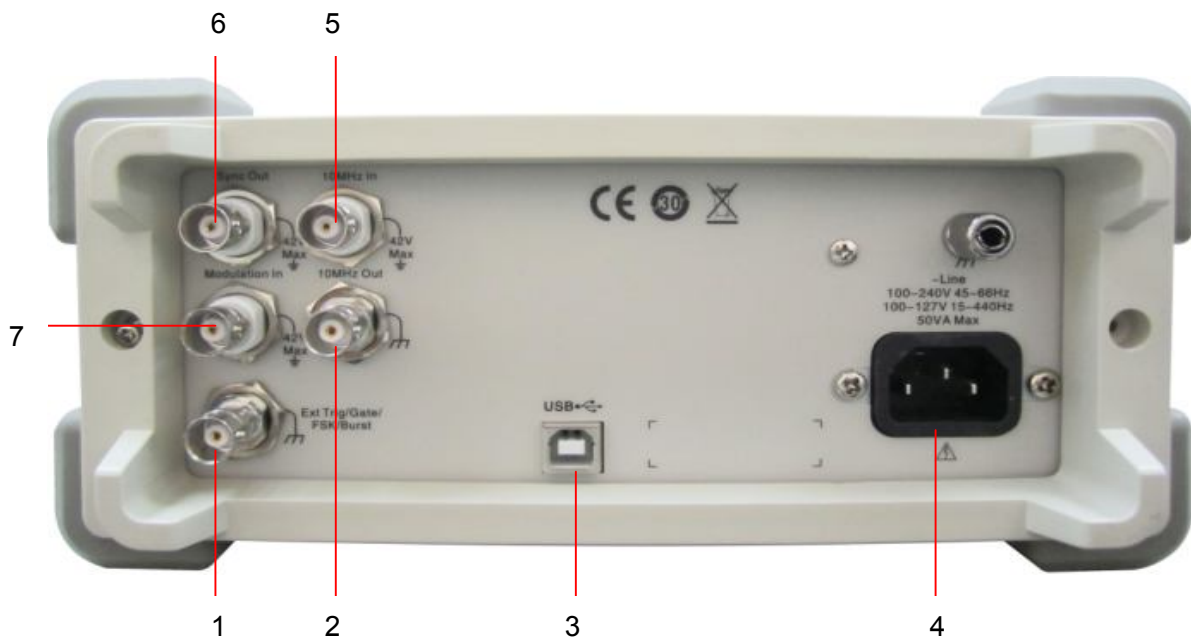

Figure1 Display Interface (Sine Wave is the default waveform)

Here are the character definitions in this Service Manual:

The signs for buttons in this manual are the same as the panel buttons. Please note that, the signs for the functional buttons on the operation panel are represented by squared words, such as Waveforms, which represents the transparent functional key with Sine on it on the front panel, while the menu buttons are represented by brighten words such as Frequency, which means the frequency option in the Sine menu.

The Rear Panel at a Glance



1. Ext Trig/Gate/FSK/Burst Connector
2. 10MHz Output Connector
3. USB Device Connector
4. Power Socket
5. 10MHz Input Connector
6. Sync Output Connector
7. Modulation Input Connector

WARNING: For protection from electric shock, the grounding power cord must not be defeated. If only a two-contact electrical outlet is available, connect the instrument's chassis ground screw (see above) to a good earth ground.

Contents

Guaranty and Declaration	I
General Safety Summary	II
Safety Terms and Symbols	III
Overview for the Document.....	IV
SDG5000 Series at a Glance.....	VI
The Front Panel at a Glance	VIII
The Rear Panel at a Glance.....	X
Specification.....	1
Specifications.....	1
General Specifications.....	7
Quick Start	8
Prepare the Generator for Use	9
Adjust the carrying Handle.....	10
Set the Output Frequency.....	11
Set the Output Amplitude.....	13
Set the DC offset	14
Set the Duty Cycle of a Square Wave.....	15
Set the Symmetry of a Ramp Wave.....	16
Generate a Pulse Waveform.....	17
Generate a Noise Waveform	19
Set the DC Voltage	21
Output a Built-In Arbitrary Waveform	22
Use the Built-In Help System.....	23
Calibration.....	24
Calibration Interval.....	24
Adjustment is Recommended.....	24
Automating Calibration Procedures.....	24
Recommended Test Equipment.....	25
Test Considerations.....	25
Performance Verification Test	26
Self Adjust	26
Performance Verification Tests	27
DC Output Verification	28
Frequency Response Verification.....	29
AC Amplitude Verification	30
General Adjustment Procedure.....	31
Warming up	31
Feedback Channel Adjustment.....	32
Channel Self Adjustment	33

Frequency Response Adjustments	34
Assembly Procedures	35
Security Consideration	35
List of Modules	36
Required Tools.....	36
Disassembly Procedures.....	36
A view of the whole Instrument	37
Removing the Handle	38
Removing the Metal Shell and Rear Cabinet.....	39
Removing the Front Cabinet.....	40
Removing the Display Module	41
Removing the Main Body.....	42
Troubleshooting	44
ESD Precautions	44
Required Equipments	44
Channel Board Drawing.....	45
Main Board Drawing	46
Check the Power Supply	47
Check the Channel Board.....	49
Voltage Checking.....	49
FPGA Checking	50
Check the Main Board	51
Voltage Checking.....	51
Mainboard Clock Checking.....	51
DSP/CPLD Checking.....	52
Quick Guide for General Failures	53
Maintenance	54
Maintain Summary.....	54
Repackaging for Shipment.....	55
Contact SIGLENT	56

Specification

These specifications apply to SDG5000 series Arbitrary Waveform Generator. To verify that an oscilloscope meets specifications, it must first meet the following conditions:

- The generator must have been operating continuously for fifteen minutes within the specified operating temperature.
- You must perform the Self Adjust operation, accessible through the Utility menu, if the operating temperature changes by more than 5 °C.
- The oscilloscope must be within the factory calibration interval of one year.

Specifications

Model	SDG5082	SDG5122	SDG5162
Maximum output frequency	80MHz	120MHz	160MHz
Output channels	2		
Sample rate	500MSa/s		
Arbitrary waveform length	CH1: 16kpts , CH2: 512kpts		
Frequency resolution	1μHz		
Vertical resolution	14 bits		
Modulation	AM, DSB- AM, FM, PM, FSK, ASK, PWM, Sweep, Burst		
Frequency counter	Frequency range: 100mHz ~ 200MHz		
Standard interface	USB Host & Device		
Dimension	W x H x D=261mm x 105mm x 344mm		

Frequency Specification

Model	SDG5082	SDG5122	SDG5162
Waveform	Sine, Square, Ramp, Pulse, Noise, Arbitrary waveform		
Sine	1 μ Hz ~ 80MHz	1 μ Hz ~ 120MHz	1 μ Hz ~ 160MHz
Square	1 μ Hz ~ 30MHz	1 μ Hz ~ 40MHz	1 μ Hz ~ 50MHz
Pulse	1 μ Hz ~ 20MHz	1 μ Hz ~ 30MHz	1 μ Hz ~ 40MHz
Ramp	1 μ Hz ~ 2MHz	1 μ Hz ~ 3MHz	1 μ Hz ~ 4MHz
Gaussian Noise	100MHz (-3dB)		
Arbitrary waveform	1 μ Hz ~ 20MHz	1 μ Hz ~ 30MHz	1 μ Hz ~ 40MHz
Resolution	1 μ Hz		
Accuracy	within 1 year \pm 2ppm 0°C ~ 55°C		

Sine Wave Spectrum Purity

Harmonic distortion	DC-1 MHz	<-54dBc
	1 MHz - 10 MHz	<-46dBc
	10 MHz - 100 MHz	<-36dBc
	100 MHz - 160 MHz	<-30dBc
Total harmonic waveform distortion	DC ~ 20 kHz	1Vpp <0.2%
Spurious signal (non-harmonic)	DC ~ 1 MHz	< -70dBc
	1 MHz ~ 10 MHz	<-70dBc+6dB/spectrum phase
Phase noise	100kHz Offset, -116dBc / Hz (typical value)	

Square Wave

Rise/Fall time (10% ~ 90%)	6ns	
Overshoot	< 3%	
Duty Cycle	1 μ Hz ~ 10 MHz	20% ~ 80%
	10 MHz (exclude) ~ 40 MHz	40% ~ 60%
	40 MHz (exclude) ~ 50 MHz	50%
Asymmetric (50% Duty Cycle)	1% of Cycle + 5 ns (typical value)	
Jitter (cycle to cycle)	< 100ps (typical value, rms)	

Pulse Wave

Period	Maximum: 1000000s Minimum: 25 ns
Pulse width	\geq 12ns, resolution: 100ps
Rise/Fall time (10% ~ 90%)	6ns ~ 6s, resolution: 100ps
Duty Cycle	0.0001% ~ 99.9999%
Overshoot	< 3%
Jitter (cycle to cycle)	< 100ps (typical value, rms)

Ramp Wave

Linearity	< 0.1% of output Peak value (typical value, 1 kHz, 1Vpp, symmetric 100%)
Symmetry	0% ~ 100%

Arbitrary Waveform

Channel	CH1	CH2
Waveform length	16kpts	512kpts
Vertical resolution	14 bits	14 bits
Sample rate	500MSa/s	500MSa/s
Minimum Rise/Fall time	5ns (typical value)	5ns (typical value)
Jitter (RMS)	2ns (maximum)	2ns (maximum)

Output Characteristics

Channel	CH1	CH2
Amplitude (50 Ω)	1mVpp~ 10Vpp (≤40MHz)	1mVpp ~ 10Vpp (≤40MHz)
	1mVpp~5Vpp (40MHz~100MHz)	1mVpp~5Vpp (40MHz~100MHz)
	1mVpp~2.5Vpp (100MHz~130MHz)	1mVpp~2.5Vpp (100MHz~130MHz)
	1mVpp ~ 1.5Vpp (130MHz~160MHz)	1mVpp ~ 1.5Vpp (130MHz~160MHz)
Vertical resolution (100 kHz sine waveform)	± (0.3dBm+1mVpp)	± (0.3dBm+1mVpp)
Amplitude flatness (based on 100kHz Sine Waveform, 1Vpp)	≤10MHz, ±0.1 dB	≤10MHz, ±0.1 dB
	≤60MHz, ±0.2 dB	≤60MHz, ±0.2 dB
	≤100MHz, ±0.4 dB	≤100MHz, ±0.4 dB
	≤160MHz, ±0.8 dB	≤160MHz, ±0.8 dB
Isolate channel depth	< -80dB	
Channel delay	< 1ns	

DC

Output characteristic	CH1	CH2
Range (DC)	±5 V (50ohm)	±5 V (50ohm)
	±10 V (high resistance)	±10 V (high resistance)
Offset accuracy	± (1%* setting offset +1 mV)	± (1%* setting offset +1 mV)

Waveform Output

Channel	CH1/CH2
Impedance	50Ω (typical value)
Protection	short-circuit protection
Isolation	The BNC connectors for channel output, synchronous and modulation input are isolated to the Re Rack Earth, and the allowable voltage range is $\pm 42\text{Vpk}$

AM/DSB-AM Modulation (CH1/CH2)

Carrier	Sine, Square, Ramp, Arbitrary (except DC)
Source	Internal/External
Modulated wave	Sine, Square, Ramp, Noise, Arbitrary
Modulation depth	0% ~ 120%
Modulation frequency	1mHz~50kHz

FM Modulation (CH1/CH2)

Carrier	Sine, Square, Ramp, Arbitrary (except DC)
Source	Internal/External
Modulation waveform	Sine, Square, Ramp, Noise, Arbitrary
Modulation frequency	1mHz ~ 50kHz

PM Modulation (CH1/CH2)

Carrier	Sine, Square, Ramp, Arbitrary (except DC)
Source	Internal/External
Modulation waveform	Sine, Square, Ramp, Noise, Arbitrary
Modulation frequency	1mHz ~ 50kHz
Phase deviation	0 ~ 360°

FSK Modulation (CH1/CH2)

Carrier	Sine, Square, Ramp, Arbitrary (except DC)
Source	Internal/External
Modulation waveform	50% duty square waveform
Key frequency	1mHz ~ 1MHz

ASK Modulation (CH1/CH2)

Carrier	Sine, Square, Ramp, Arbitrary (except DC)
Source	Internal/External
Modulation waveform	50% duty square waveform
Key frequency	1mHz ~ 1MHz

PWM Modulation (CH1/CH2)

Carrier	Pulse
Source	Internal/External
Modulation waveform	Sine, Square, Ramp, Noise, Arbitrary
Modulation frequency	1mHz ~ 50kHz

Sweep (CH1/CH2)

Carrier	Sine, Square, Ramp, Triangle, Arbitrary (except DC)
---------	---

Type	linear/logarithmic
Direction	Up/ down
Sweep time	1ms ~ 500s ± 0.1%
Trigger source	Manual, external, internal

Burst (CH1/CH2)

Waveform	Sine, Square, Ramp, Pulse, Noise, Arbitrary (except DC)
Carrier frequency	2mHz ~ 100MHz
Type	Count (1 ~ 1000000 cycles) , infinite, Gated
Start/Stop phase	0° ~ 360°
Internal cycle	1μs ~ 1000s ± 1%
Trigger delay	296ns ~ 34s
Gated source	External trigger
Trigger source	Manuel, External or Internal

External Modulation Input

Connector	The rear panel BNC connector, isolated to the Re Rack Earth
Input amplitude	± 4.5Vpk=100% modulation, input impedance >5kΩ

The external input voltage can't be over ± 5Vpk, or the instrument will get damaged.

Trigger Input

Connector	The rear panel BNC connector, rack (reference)
Voltage level input	TTL compatible
Slope	Up or down (optional)
Pulse width	> 50 ns
Input impedance	> 5kΩ, DC coupling
Response time	380ns (typical value)

Trigger Output

Connector	The rear panel BNC connector, rack (reference)
Voltage level	TTL compatible
Pulse width	> 60ns (typical value)
Output impedance	50Ω (typical value)
Maximum frequency	1 MHz

SYNC Output

Connector	The rear panel BNC connector, isolated to the Re Rack Earth
Voltage level	TTL compatible
Pulse width	> 50 ns (typical value)
Output impedance	50Ω (typical value)
Maximum frequency	10MHz

REFCLK Input(10MHz ~ In)

Connector	The rear panel BNC connector, isolated to the Re Rack Earth and all the other connectors.
Lock range	10MHz \pm 50Hz
Signal level	2.3Vpp ~ 3.3Vpp
Lock Time	< 2 s
Input impedance	1K Ω , AC coupling

REFCLK Input(10MHz ~ Out)

Connector	The rear panel BNC connector, rack (reference)
Output frequency	10MHz
Signal level	>1Vpp
Output impedance	50 Ω , AC coupling

Frequency Counter

Measurement	Frequency, Period, positive/negative Pulse Width, Duty Cycle
Frequency range	Single Channel: 100mHz ~ 200 MHz
Frequency resolution	6 bits/s
Voltage range and sensitivity(non-modulated signal)	

Manual	DC coupling	DC deviation range	\pm 1.5 VDC
		100mHz ~ 100 MHz	50mVrms ~ \pm 2.5V
	100 MHz ~ 200 MHz	100mVrms ~ \pm 2.5V	
	AC coupling	1 Hz ~ 200 MHz	100mVrms ~ 5Vpp
Pulse Width and Duty measurement	6Hz ~ 10MHz (80mVrms ~ 5Vpp)		
Input adjustment	Input impedance	1 M Ω	
	Coupling mode	AC/DC	
	HFR	On/Off	
Trigger method	Trigger level range: -3 v ~ 1.8v		

General Specifications

Display

Display type	4.3'TFT-LCD
Resolution	480×RGB×272
Color	24bit
Contrast (typical value)	500:1
Backlight intensity (typical)	300cd/m ²

Power

Voltage	100~240 VACRMS, 45~66 Hz, CATII
	100~127 VACRMS, 45~440 Hz, CATII
Power	< 30W
Fuse	1.25A, 250V

Environment

Environmental Temperature	Operation: 0°C ~ 40°C
	Non-operation: -20°C ~ 60°C
Cooling method	natural cooling down
Humidity range	Below +35°C: ≤90% relative humidity
	+35°C ~ +40°C: ≤60% relative humidity
Altitude	Operation: < 3,000m
	Non-operation: <15,000m

Mechanical

Dimension	Width: 261mm
	Height: 105mm
	Depth: 344mm
Weight	N.W: 2.8 Kg

IP Protection

IP2X

Calibration Cycle

1 year

Quick Start

One of the first things you will want to do with your generator is to become acquainted with the front panel. We have written the exercises in this chapter to prepare the instrument for use and help you get familiar with some of its front-panel operations. This chapter is divided into the following sections:

- To Prepare the Generator for Use
- To Adjust the Carrying Handle
- To Set the Output Frequency
- To Set the Output Amplitude
- To Set a DC Offset Voltage
- To Set the Duty Cycle of a Square Wave
- To Set the Symmetry of a Ramp Wave
- To Configure a Pulse Waveform
- To Configure a Noise Waveform
- To Select “DC Volts”
- To Output a Built-In Arbitrary Waveform
- To Use the Built-In Help System

Prepare the Generator for Use

1. Check the list of accessories

Accessories supplied with the instrument are listed below. If anything is missing or damaged, please contact your nearest **SIGLENT** Sales Office.

- A Quick Start
- A Certification
- A Guaranty Card
- A CD(EasyWave software, DataSheet and User Manual)
- A power cord that fits the standard of destination country
- A USB cable

2. Connect the power cord and turn on the generator

The instrument runs a short power-on self test, which takes a few seconds.

The generator powers up in the *sine wave* function at 1 kHz with an amplitude of 4V_{peak-to-peak} (Channel 1). At power-on, the Output connector is disabled. To enable the Output connector, press the **Output** key.

If the generator does not turn on, verify that the power cord is firmly connected to the power socket on the rear panel (the power-line voltage is automatically sensed at power-on). You should also make sure that the generator is connected to a power source that is energized.

Then, verify that the generator is turned on.

Note: *If the power-on self test fails, the generator may stop with black screen. For solutions, please contact the nearest **SIGLENT** sales office or return the generator to **SIGLENT** for service.*

Adjust the carrying Handle

To adjust the position, grasp the handle by the sides and pull outward. Then, rotate the handle to the desired position.

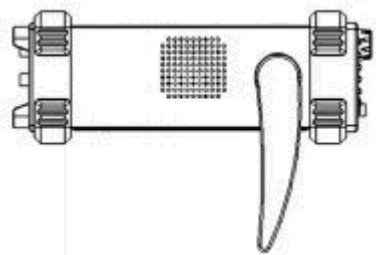
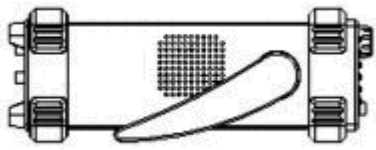

Pull the handle down

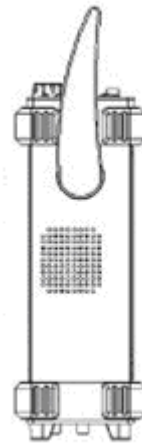

Pull the handle ahead for easy carrying

Set the Output Frequency

The following steps show you how to change the frequency to 20 KHz.

1. Press the **Store/Recall** softkey

Press the Store/Recall softkey to enter the parameter set interface. The waveform parameters including Frequency/Period, Amplitude/HighLevel, Offset/LowLevel and Phase are for you to modify using the numeric keypad.

2. Press the **Frequency/Period** softkey

The displayed frequency is either the power-on value or the frequency previously selected. When you change the function, the same frequency is used if the current value is valid for the new waveform. If you want to set the period, press the softkey again to switch to the period parameter

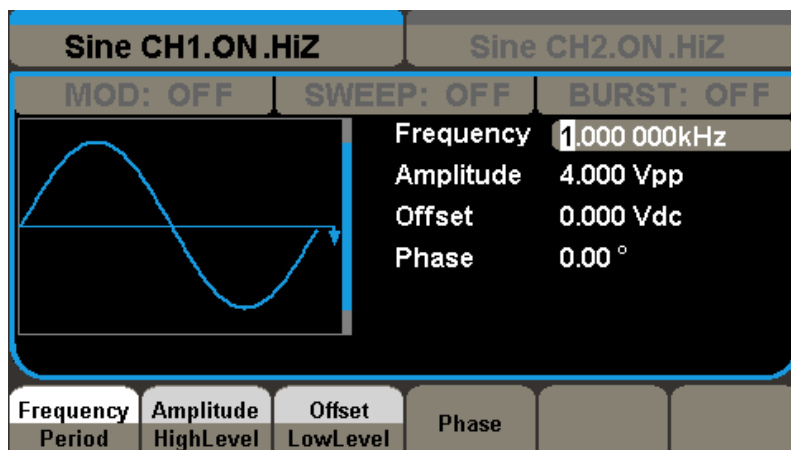

2. Input the desired frequency

Use the digital keypad to input the value directly, enter the value “20”.

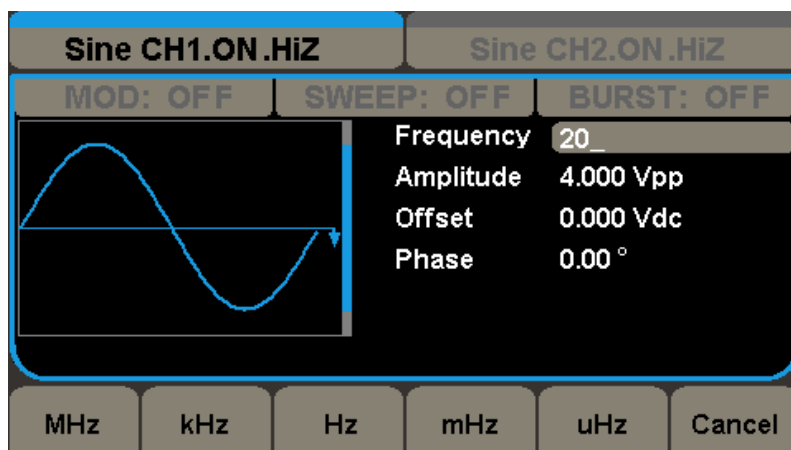

Then press the corresponding softkey to select the desired unit. For example, press **KHz**.

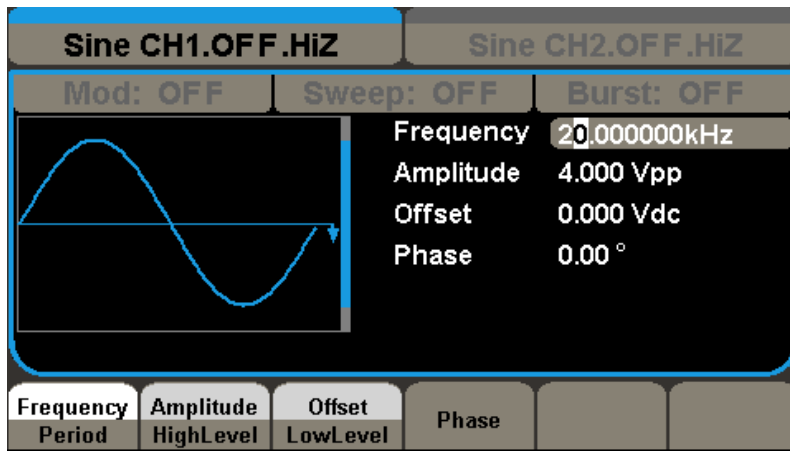

Note: You can also enter the desired value using the knob and direction keys.

Set the Output Amplitude

The following steps show you how to change the amplitude to 8Vpp.

1. Press the **Ampl/HLevel** softkey

The displayed amplitude is either the power-on value or the amplitude previously selected. When you change the function, the same amplitude is used if the current value is valid for the new waveform. If you want to set the **HLevel** for the waveform, press the softkey again to switch to the **HLevel** parameter.

2. Input the desired amplitude

Use the digital keypad to input the value directly, enter the value “8”.

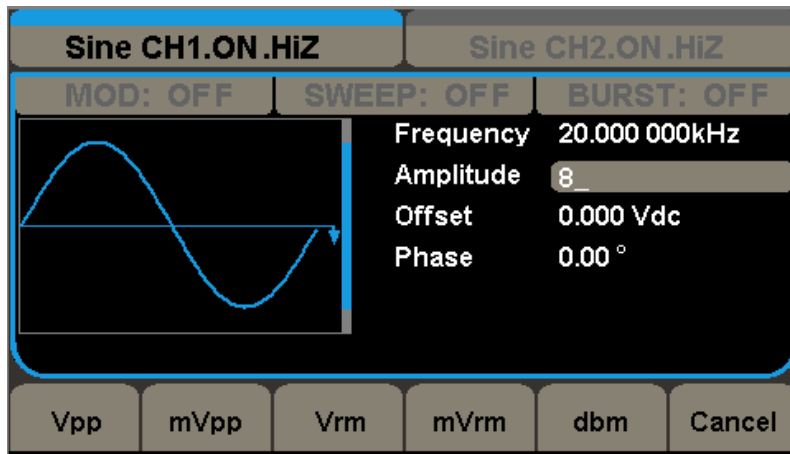

Then press the corresponding softkey to select the desired unit. For example, press **Vpp**.

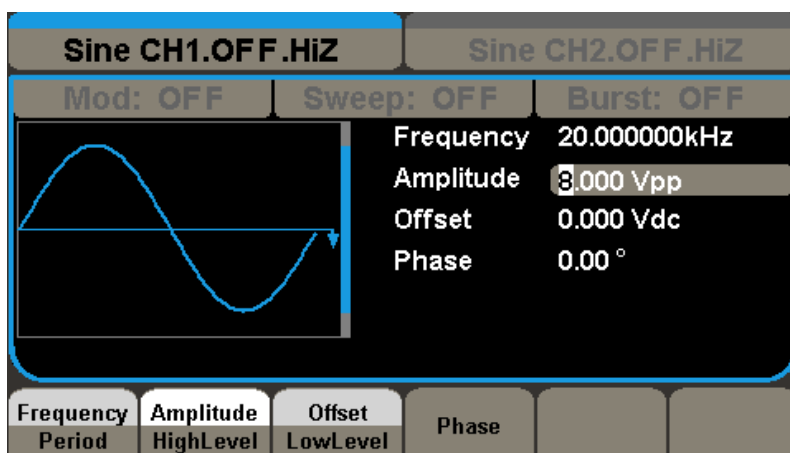

Note: You can also enter the desired value using the knob and direction keys.

Set the DC offset

The following steps show you how to change offset to 1Vdc.

1. Press the **Offset/LLevel** softkey

The displayed offset is either the power-on value or the offset previously selected. When you change the function, the same offset is used if the current value is valid for the new waveform. If you want to set the LLevel for the waveform, press the softkey again to switch to the LLevel parameter.

2. Input the desired offset

Use the digital keypad to input the value directly, enter the value “1”.

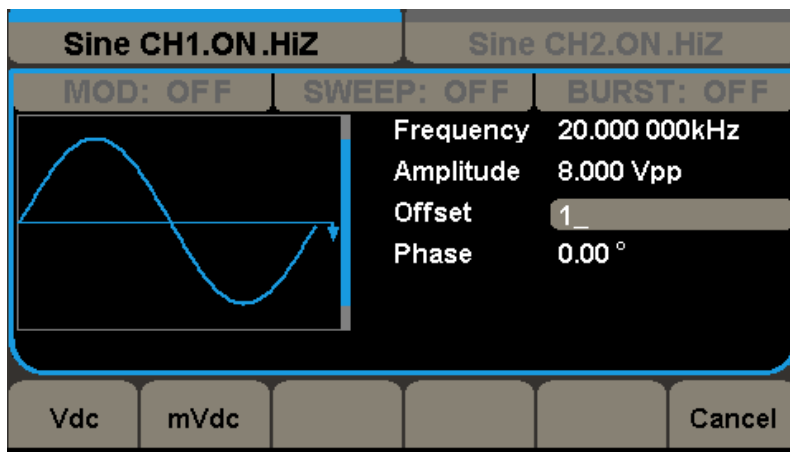

Then press the corresponding softkey to select the desired unit. For example, press **Vdc**.

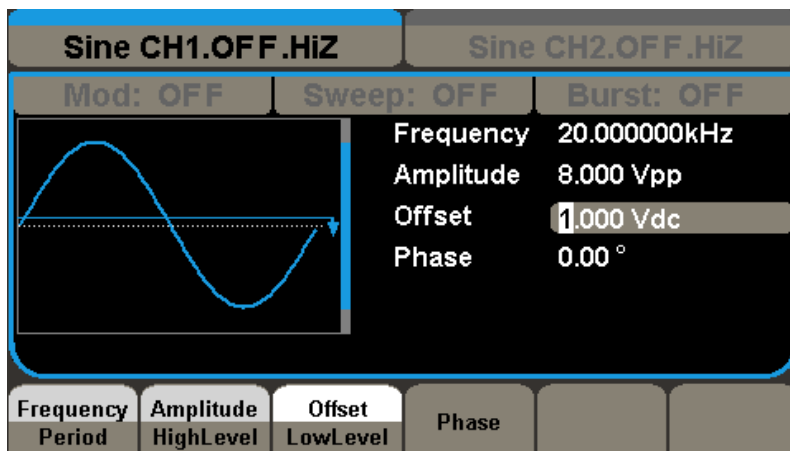

Note: You can also enter the desired value using the knob and direction keys.

Set the Duty Cycle of a Square Wave

At power-on, the default duty cycle for square wave is 50%. You can adjust the duty cycle from 20% to 80% for output frequencies up to 50 MHz. The following steps show you how to change the duty cycle to 80%.

1. Select the square wave function

Press **Square** button and then select the desired output frequency to any value up to 50 MHz.

2. Press the **Duty** softkey

Firstly you should press Store/Recall button to enter the parameter setting interface. The displayed duty is either the power-on value or the percentage previously selected.

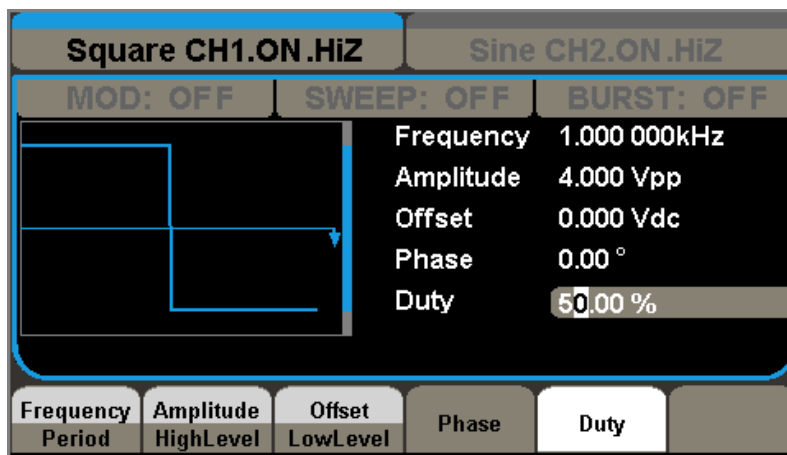

3. Input the desired duty

Use digital keypad to input the value directly, enter the value “80”, then press the corresponding softkey to select the desired unit “%”.

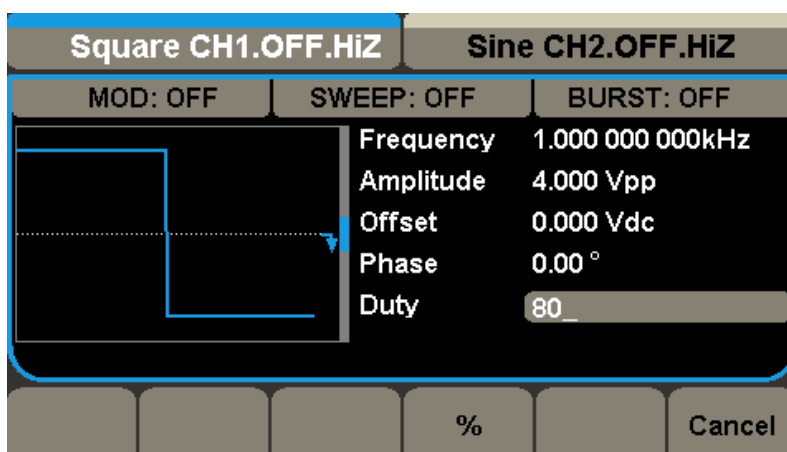

Set the Symmetry of a Ramp Wave

At power-on, the Symmetry for Ramp wave is 50%. You can adjust the symmetry from 0% to 100%. The following steps show you how to change the symmetry to 60%.

1. Select the Ramp wave function

Press **Ramp** button and then select the desired output frequency to 4MHz.

2. Press the **Symmetry** softkey

Firstly you should press Store/Recall button to enter the parameter setting interface. The displayed symmetry is either the power-on value or the percentage previously selected.

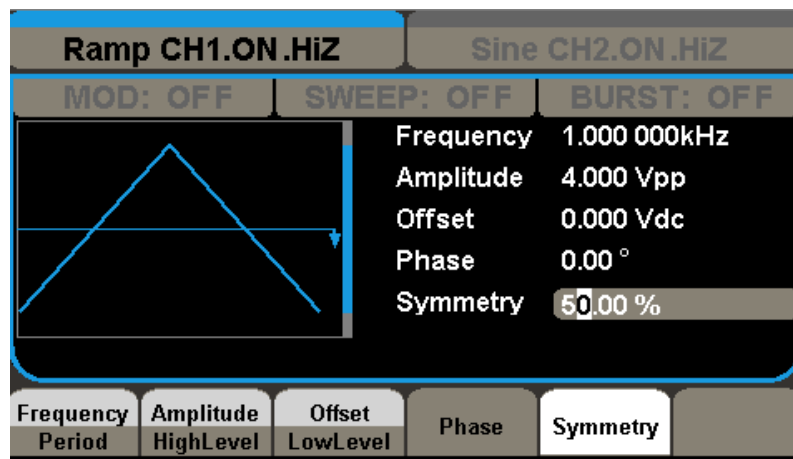

3. Input the desired symmetry

Use digital keypad to input the value directly, enter the value “60”, then press the corresponding softkey to select the desired unit “%”.

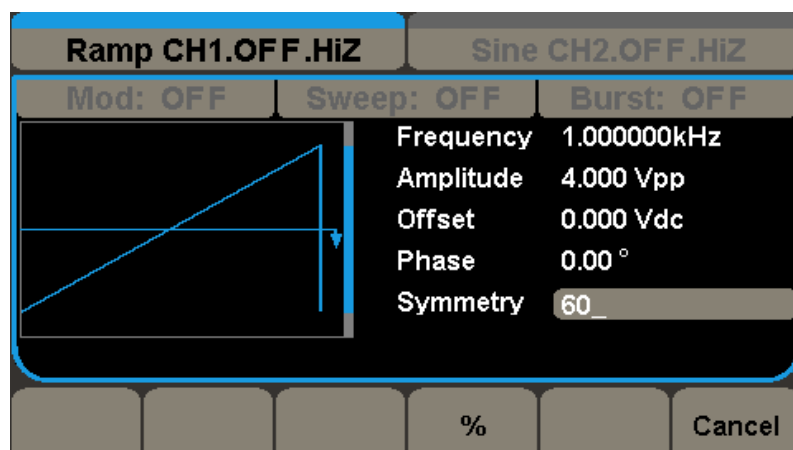

Generate a Pulse Waveform

You can set the generator to output a pulse waveform with variable width, edge time and delay time. The following steps show you how to generate a 500 μs pulse waveform with a pulse width of 100 μs , rise time of 8ns and delay time of 50 ns.

1. Select the pulse function

Press the **Pulse** button to select the pulse function and output a pulse waveform with the default parameters.

2. Set the Pulse period

Press the **FrequencyPeriod** softkey twice and then set the period to 500 μs .

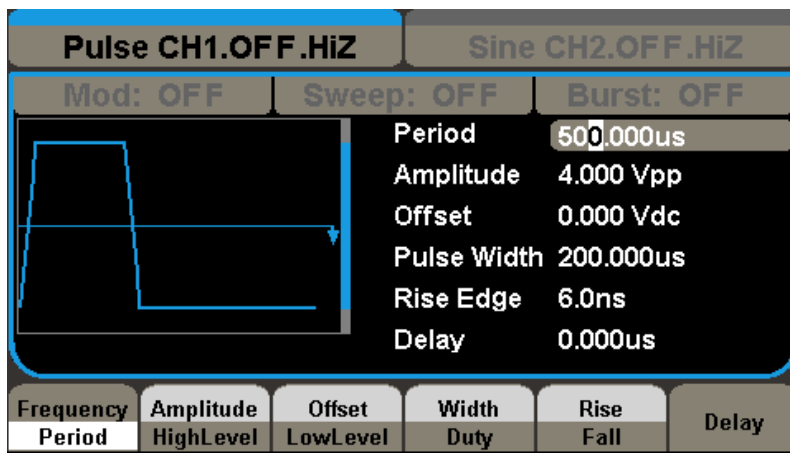

3. Set the Pulse Width

Press the **Width/Duty** softkey and then set the pulse width to 100 μs . The pulse width represents the time from the 50% threshold of the rising edge to the 50% threshold of the next falling edge.

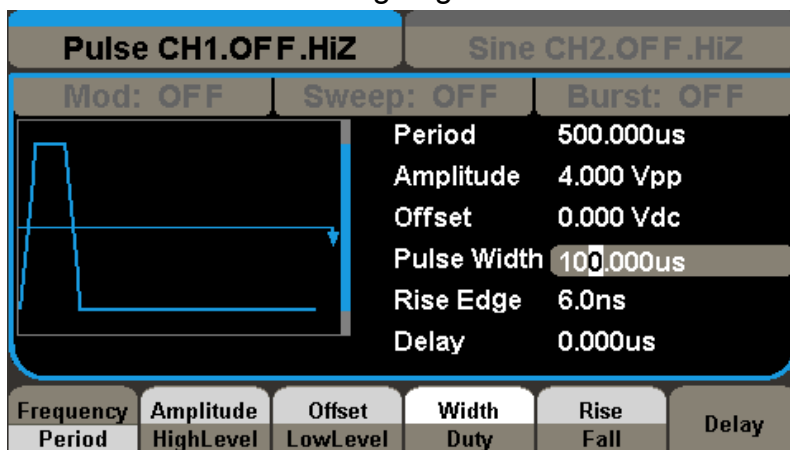

4. Set the Edge Time

Press the **Rise/Fall** softkey and then set the rise edge to 8 ns.

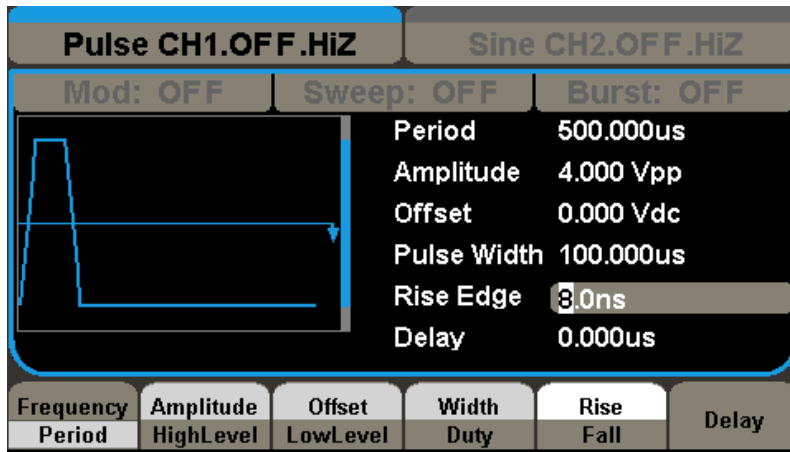

5. Set the Pulse Delay

Press the **Delay** softkey and then set the delay time to 50 ns.

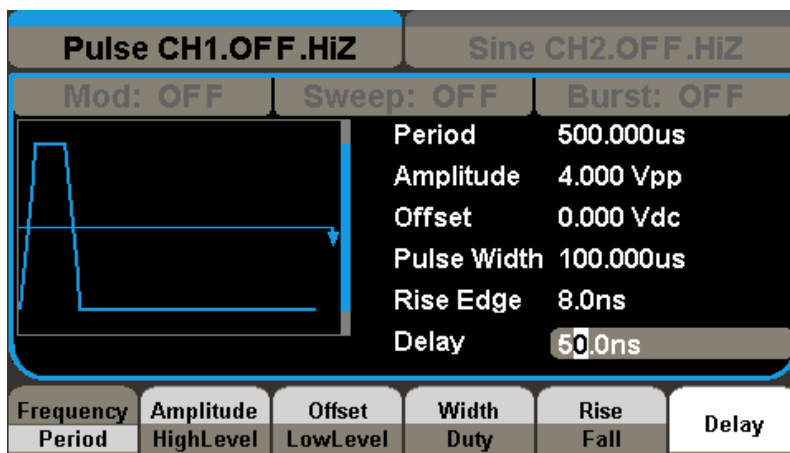

Generate a Noise Waveform

You can set the generator to output a noise waveform with Stdev and Mean. The following steps show you how to generate a noise waveform with 500mV Stdev and 1mV Mean.

1. Select the Noise function

Press the **Noise** button to select the noise function and output a noise waveform with the default parameters.

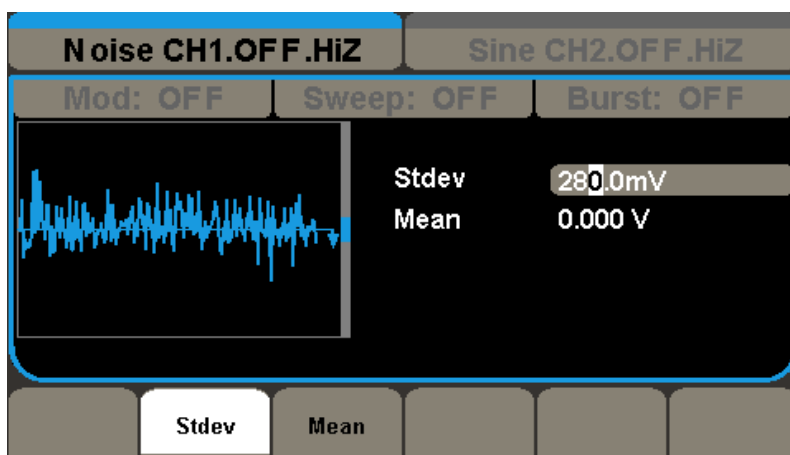

2. Set the Stdev

Press the **Stdev** softkey and then set the Stdev to 500mV.

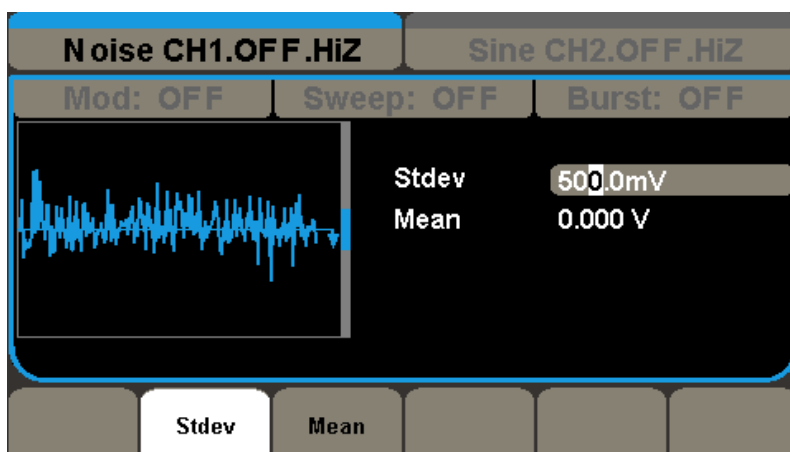

3. Set the Mean

Press the **Mean** softkey and then set the mean to 1mV.

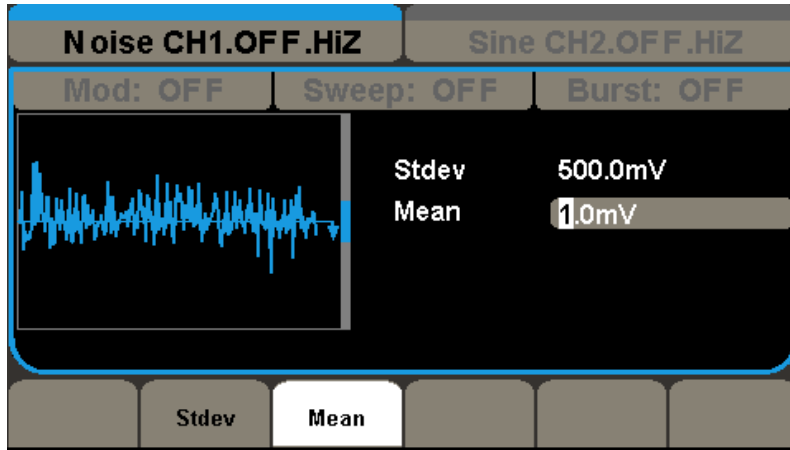

Set the DC Voltage

You can set the DC Voltage feature from the Utility Menu, and then set a dc voltage as an “Offset” value. The following steps show you how to set a dc voltage with +1Vdc.

1. Select the **Store/Recall** function

Press the Store/Recall button to enter the parameter setting interface.

2. Set the DC Voltage

Press the **DC** button to select the DC function and output a DC waveform with the default parameter.

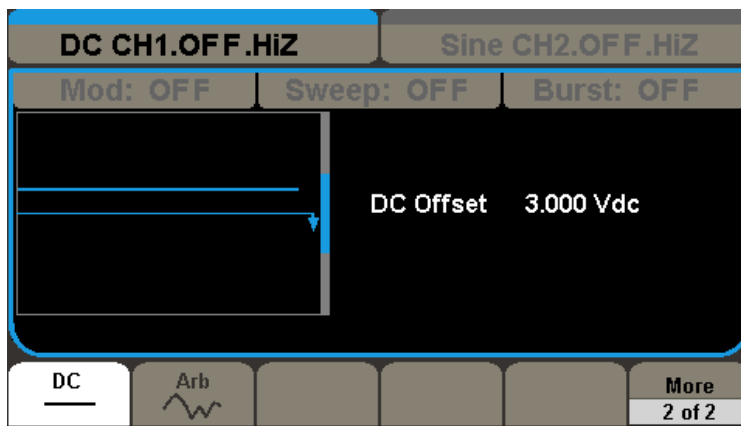

3. Set the DC Offset

Press the **Offset** softkey and then set the offset to 1V.

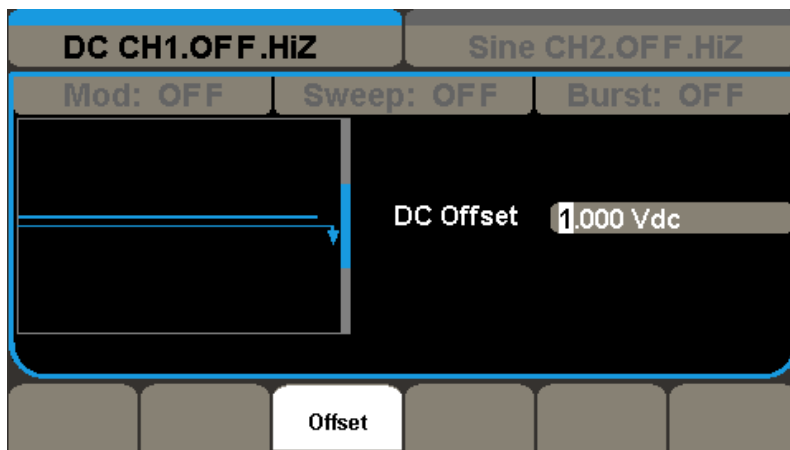

Output a Built-In Arbitrary Waveform

There are 36 built-in arbitrary waveforms stored in non-volatile memory. The following steps show you how to output the built-in “exponential fall” waveform from the front panel.

1. Set the arbitrary waveform function

Press the **Arb** button to select the arbitrary waveform function. Then press the **Built-In** softkey to enter the arbitrary waveform setting interface.

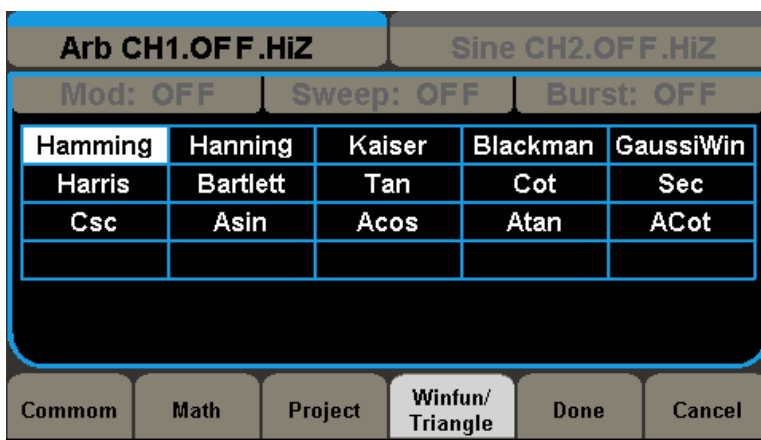

2. Set the Math waveform

Press the **Math** softkey to display the mathematic waveform as below.

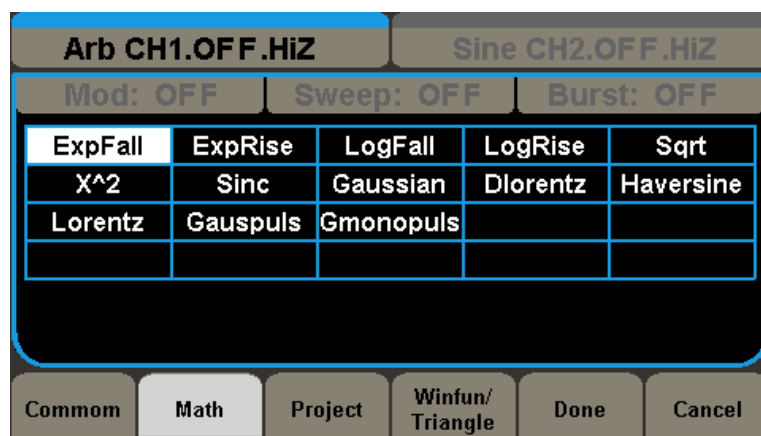

3. Output the exponential fall waveform

Rotate the knob to select the ExpFall waveform and press the **Done** softkey. The waveform is output with the present settings unless you change them.

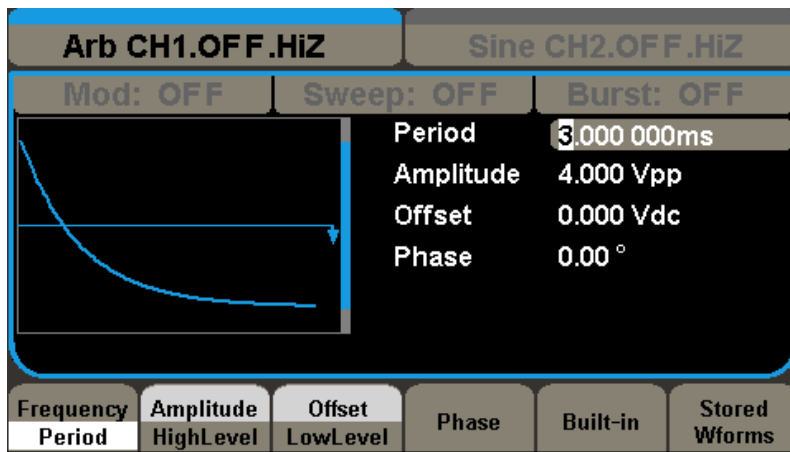

Use the Built-In Help System

The built-in help system is designed to provide context-sensitive assistance of some functions. A list of help topics is also available to assist you with several operations.

1. Read the help information for SDG5000

Press **Help** button in utility system, you will see a list of help topics as below. With easy operations on the front panel, you could read any help item you desired.

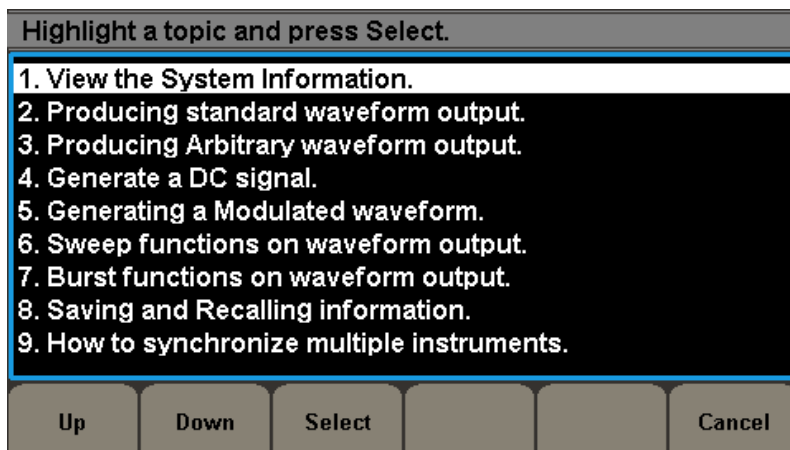

2. Press “Candle” or any function button to exit the help system

Calibration

This calibration procedure contains performance verification procedure and adjustment procedure. After receiving a generator, you should firstly verify if its performance applies to the limits, and then perform adjustment in case of abnormal testing results.

Calibration Interval

The instrument should be calibrated on a regular interval determined by the measurement accuracy requirements of your application. A 1-year interval is adequate for most applications. Accuracy specifications will remain valid only if adjustment is made at regular calibration intervals. Accuracy specifications are not valid beyond the 1-year calibration interval. SIGLENT does not recommend extending calibration intervals beyond 2 years for any application.

Adjustment is Recommended

Specifications are valid only within the period from the last adjustment. Whatever calibration interval you select, **SIGLENT** recommends that re-adjustment should always be performed within the calibration interval. This is necessary to ensure the accuracy of the performance data measured during the calibration interval.

Automating Calibration Procedures

You can automate the complete verification and adjustment procedures outlined in this chapter if you have access to programmable test equipment. You can program the instrument configurations specified for each test over the remote interface. You can then enter read-back verification data into a test program and compare the results to the appropriate test limit values.

You can also adjust the instrument from the remote interface. Remote adjustment is similar to the local front-panel procedure. You can use a computer to perform the adjustment by first selecting the required function and range. The adjustment command is sent to the instrument and then the adjustment is initiated over the remote interface.

Recommended Test Equipment

The test equipment recommended for the performance verification and adjustment procedures is listed below. If the exact instrument is not available, substitute calibration standards of equivalent accuracy.

Instrument	Requirements	Recommended Model
Digital Multimeter(DMM)	dc volts accuracy: 100ppm resolution: 100 μ V	Agilent 34401A
Power Meter	Frequency: 10KHz to 50MHz	Agilent U2004
GPIB cable		GPIB(IEEE488)
Frequency Counter	Accuracy: 1ppm	
Digital Oscilloscope	200MHz Bandwidth	Agilent DSOX3024A

Test Considerations

For optimum performance, all procedures should comply with the following recommendations:

- Assure that the calibration ambient temperature is stable and between 18 °C and 28°C. Ideally, the calibration should be performed at 23°C \pm 1°C.
- Assure ambient relative humidity is less than 80%.
- Allow a half an hour warm-up period before verification or adjustment.
- Keep the measurement cables as short as possible, consistent with the impedance requirements.
- Use a 50 Ω cable.

Performance Verification Test

Use the performance verification tests to verify the measurement performance of the instrument. The performance verification tests use the instrument's specifications listed in the "Specifications" chapter.

You can perform two different levels of performance verification tests:

- **Self Adjust** A series of internal verification tests that give high confidence that the instrument is operational.
- **Performance Verification Tests** An extensive set of tests that are recommended as an acceptance test when you first receive the instrument or after performing adjustments.

Self Adjust

A brief power-on Self Test occurs automatically whenever you turn on the instrument. This limited test assures that the instrument is operational.

To perform a complete self Adjust:

1. Press **Utility** button on the front panel and enter to page 2.
2. Select the **Test/Cal** softkey, and then select the **Self Adjust** softkey.

The instrument will automatically perform the complete Self Adjust procedure when you release the key. The Self Adjust will complete in approximately 20 seconds.

- There is a progress bar show on the screen during the Self Adjust.
- If the Self Adjust is successful, "100%" is displayed over the progress bar.
- If the Self Adjust fails, the progress halts at some values.
- If repair is required, see chapter 5, "Troubleshooting", for further details.

Performance Verification Tests

The performance verification tests are recommended as acceptance tests when you first receive the instrument. The acceptance test results should be compared against the specifications given in chapter 1. After acceptance, you should repeat the performance verification tests at every calibration interval.

If the instrument fails performance verification, adjustment or repair is required.

Adjustment is recommended at every calibration interval. If adjustment is not made, you must guard band, using no more than 80% of the specifications listed in chapter 1, as the verification limits.

DC Output Verification

This test checks if the DC offset listed in the table below are within the spec range using a DMM.

1. Set the DMM to measure DC voltage. Connect the DMM to the channel 1 output of the generator as shown below.

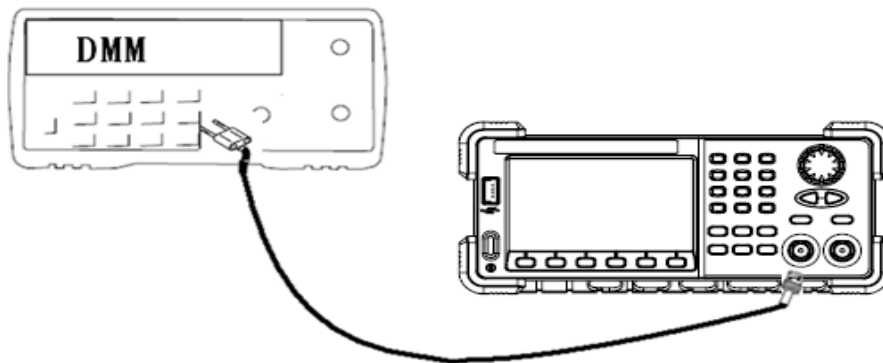

2. Turn on channel 1 and select DC system under the Utility menu.
3. Set the instrument to each output value described in the table below and measure the output voltage with the DMM. Be sure the generator output impedance is set to High-Z and the output is enabled.

DC Offset	CH1	CH2	Spec Range $\pm (1\%+3\text{mv})$
0mv			-1mv ~ 1mv
10mv			8.9mv ~ 11.1mv
100mv			98mv ~ 102mv
1v			0.989v ~ 1.011v
3v			2.969v ~ 3.031v
10v			9.899 ~ 10.101
-10mv			-11.1mv ~ - 8.9mv
-100mv			-102mv ~ 98mv
-1v			-1.011v ~ 0.989v
-3v			-3.031v ~ 2.969v
-10v			10.101v ~ 9.899v

4. Compare the measured voltage to the spec range shown in the table above.

Frequency Response Verification

This test checks if the value in dB format translated from output amplitude is within the spec range response to different frequency using a Power Meter.

1. Turn on the generator and choose CH1 as the operating channel. Set the Load to 50Ω under the CH1/CH2 menu.
2. Connect the Power Meter, PC and generator as shown below.

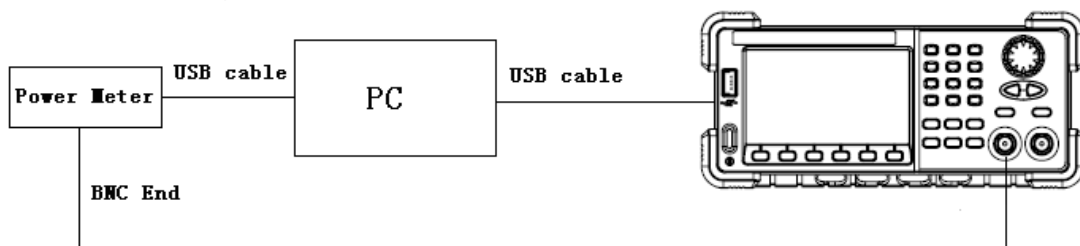

3. Select Sine waveform of the generator and set the amplitude to 1V and 2.5V, frequency to the values listed below in sequence.

Output Voltage	1V			2.5V		
	CH1	CH2	the Spec Range (dBm)	CH1	CH2	the Spec Range (dBm)
10KHz			3.8794 ~ 4.0794			11.84 ~12.04
100KHz			3.8794 ~ 4.0794			11.84 ~12.04
1MHz			3.8794 ~ 4.0794			11.84 ~12.04
5MHz			3.8794 ~ 4.0794			11.84 ~12.04
10MHz			3.8794 ~ 4.0794			11.84 ~12.04
20MHz			3.7794 ~ 4.1794			11.74 ~12.14
30MHz			3.7794 ~ 4.1794			11.74 ~12.14
50MHz			3.7794 ~ 4.1794			11.74 ~12.14
80MHz			3.5794 ~ 4.3794			11.54 ~12.34
100MHz			3.5794 ~ 4.3794			11.54 ~12.34
110 MHz			3.1794 ~ 4.7794			11.14 ~12.74
120 MHz			3.1794 ~ 4.7794			11.14 ~12.74
160MHz			3.1794 ~ 4.7794			11.14 ~12.74

4. Remove the BNC cable to CH2 output and perform the same verification as channel1.
5. Compare the value measured from Power Meter to the spec range shown in the table above.

AC Amplitude Verification

This test checks the ac amplitude output accuracy at the frequency of 100 kHz using a Power Meter.

1. Turn on the generator and choose CH1 as the operating channel. Set the Load to 50Ω under the CH1/CH2 menu.
2. Connect the Power Meter, PC and generator as shown below.

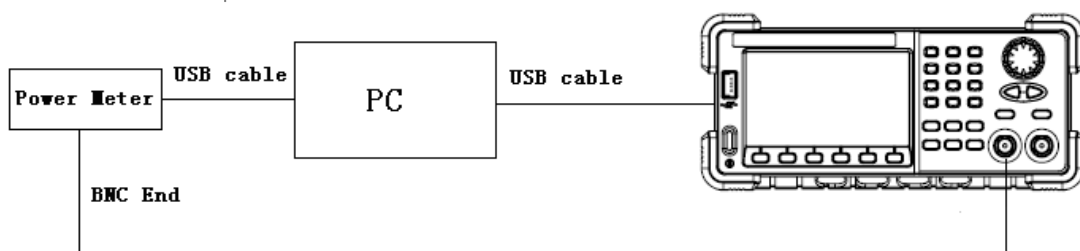

3. Select Sine waveform of the generator and set the amplitude to the values listed below in sequence.

Amplitude	CH1 (dBm)	CH2 (dBm)	the Spec Range (dBm)
40mv			-24.50 ~ -23.46
200mv			-10.34 ~ -9.65
500mv			-2.35 ~ -1.72
2v			9.69 ~ 10.3
5v			17.65 ~ 18.26

4. Remove the BNC cable to CH2 output and perform the same verification as channel1.
5. Compare the value measured from Power Meter to the spec range shown in the table above.

General Adjustment Procedure

This chapter explains how to adjust the SDG5000 series generator for optimum operating performance. The following contents are the three adjustment steps:

- **Feedback channel Adjustment** which act as a standard calibration module, providing the accuracy assurance for Self Adjust.
- **Channel Self Adjustment** which includes internal control channel adjustment and signal channel adjustment.
- **Frequency Response Adjustment** which could properly compensate the amplitude as the frequency increases.

Warming up

Before performing the adjustment procedures, you must let the oscilloscope and other test equipments warm up for at least 15 minutes in an ambient temperature between 20 °C and 30 °C. Adjustments performed prior to warm-up or outside this temperature range may result in poor performance.

Feedback Channel Adjustment

The internal feedback channel receives the feedback signal from all the other channels that are performing self adjustment. This adjustment acts as a standard test module and must be performed prior to Self Adjust to make sure it is performed based on a best adjusting accuracy.

1. Turn on the generator.
2. Connect the DMM, PC and SDG5000 generator as shown below:

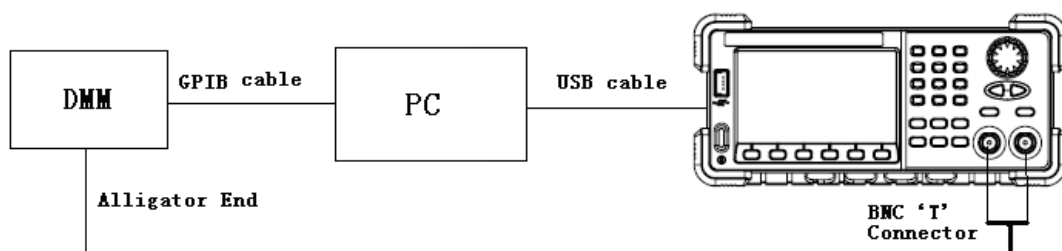

3. Open the EasyTest software on the desktop, and run the feedback channel script prepared previously. The CH2 will be automatically turned on upon running of the script.

Channel Self Adjustment

This adjustment is for internal control channel and signal channel. Through feedback circuits of the feedback channel and signal channel, this adjustment helps to obtain the actual working performance for components from signal channels.

1. After the feedback channel adjustment completed, disconnect the two BNC cables on channel 1 and channel 2.
2. Select “Self Adjust” to perform the channel Self Adjustment in Test/Cal system under the Utility menu.
3. Once the “Self Adjust” begins, the generator turns to adjustment interface and the progress bar displays on the screen. In about 15 seconds it will reach to 100%, which indicates completing of the self-adjust. You could press any functional button to exit.

Frequency Response Adjustments

This adjustment aims to obtain the actual frequency response characteristic of signal channel, thus to perform appropriate compensation. Since the waveform amplitude will decrease as the input frequency increases, it is essential to compensate for the amplitude to match it to the frequency.

1. Turn on the generator and connect it to PC using a USB cable.
2. Connecting the USB end of the Power Meter to the USB port of the PC, upon which the Power Meter indicator light will be brightened. Only after the indicator light goes out from red, could it be connected to the generator output.
3. Open the EasyTest software on the desktop, and run the corresponding script prepared previously. In about 10 seconds the prompt message will display on the screen to indicate you to connect the Power Meter. After the generator completes adjustment for channel 1, the prompt message displays on the screen will indicate you to remove the BNC cable to channel 2 to start adjustment.

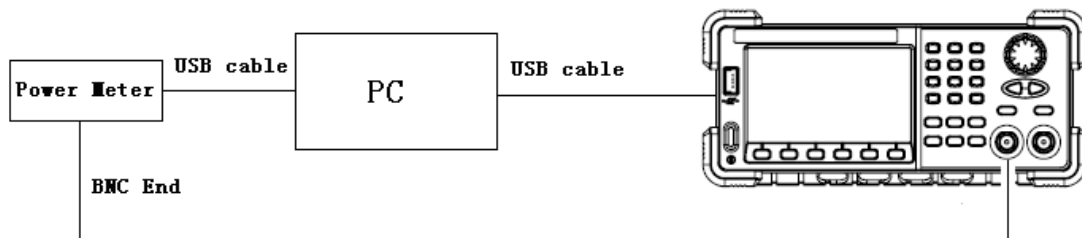

4. After the two channel adjustment completed, please disconnect all connections.

Assembly Procedures

This chapter describes how to remove the major modules from the SDG5000 series generator. To install the removed modules or replace new modules, please follow corresponding operating steps in reverse order.

The following contents are what mainly included in this chapter:

- **Security Consideration** which describes security information needed to considerate while operating.
- **List of Module** in which the modules to remove are listed.
- **Required Tool** which describes the tools needed to perform the procedures
- **Disassembly Procedures** which describes in detail how to remove and install the modules

Security Consideration

Only qualified personnel should perform the disassembly procedures. Whenever possible, disconnect the power before you begin to remove or replace the modules. Otherwise, any personal injuries or damages to the components may occur.

Avoid Electric Shock Hazardous voltages exist on the LCD module and power supply module. To avoid electrical shock, you should firstly disconnect the power cord from the oscilloscope, and then wait at least three minutes for the capacitors in the oscilloscope to discharge before you begin disassembly.

Preventing ESD Almost all electrical components can be damaged by electrostatic discharge (ESD) during handling. Component damages can occur at electrostatic discharge voltages as low as 50 volts. The following guidelines will help preventing ESD damage when servicing the instrument or any electronic device.

- ◆ Disassemble instruments only in a static-free work area.
- ◆ Use a conductive work area to reduce static charges.
- ◆ Use a conductive wrist strap to reduce static charge accumulation.

- ◆ Minimize handling.
- ◆ Keep replacement parts in original static-free packaging.
- ◆ Remove all plastic, foam, vinyl, paper and other static-generating materials from the immediate work area.
- ◆ Use only anti-static solder suckers.

List of Modules

The following removable modules are listed in the order of performing disassembly procedures.

Number of Module	Module
1	Handle
2	Metal Shell and Rear Cabinet
3	Front Cabinet
4	Display Module
5	Main Body

Required Tools

Use the tool to remove or replace the modules in the oscilloscope:

- PH2 phillips screwdriver

Disassembly Procedures

This section describes how to remove and install the modules listed above in the generator in detail. Complete disassembly will be best achieved through the following operating steps.

A view of the whole Instrument

The disassembly drawing are shown as below for you to disassemble the generator in right steps. Before disassembling, please cut the power to avoid any personal injuries or damages to inside components. Since some modules of the instrument are sharp, you should also take care while operating to prevent being scratched.

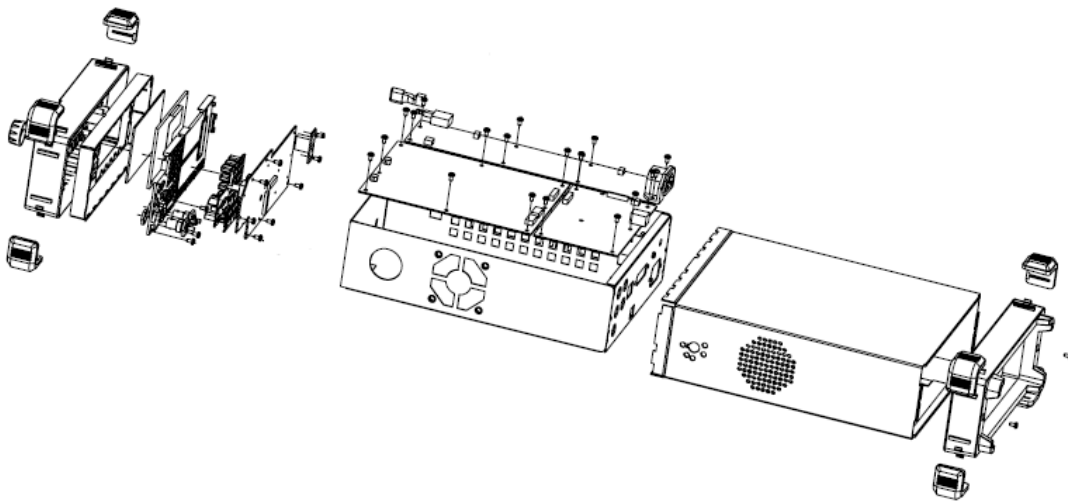

Table 4-1 A view of the whole instrument

Removing the Handle

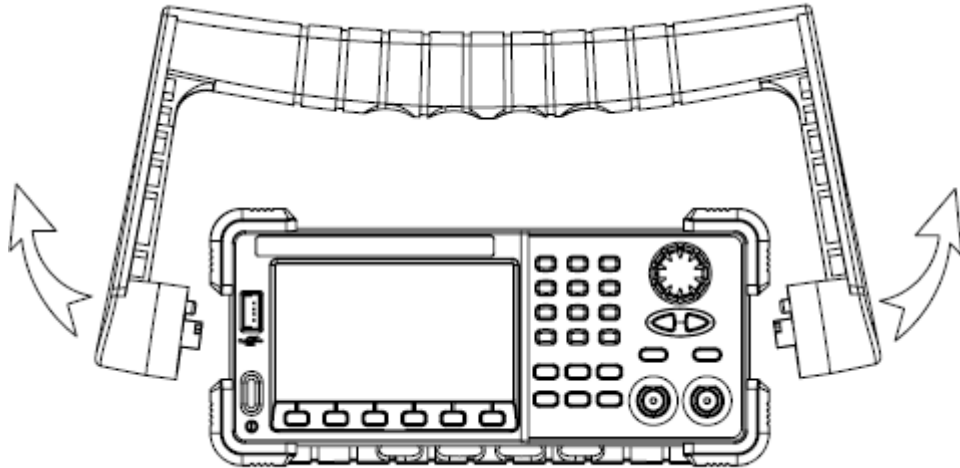

Table 4-2 Removing the handle

Removing steps:

Pull down the handle hard from the two sides of the generator.

To install the handle, please operate as the reverse steps.

Removing the Metal Shell and Rear Cabinet

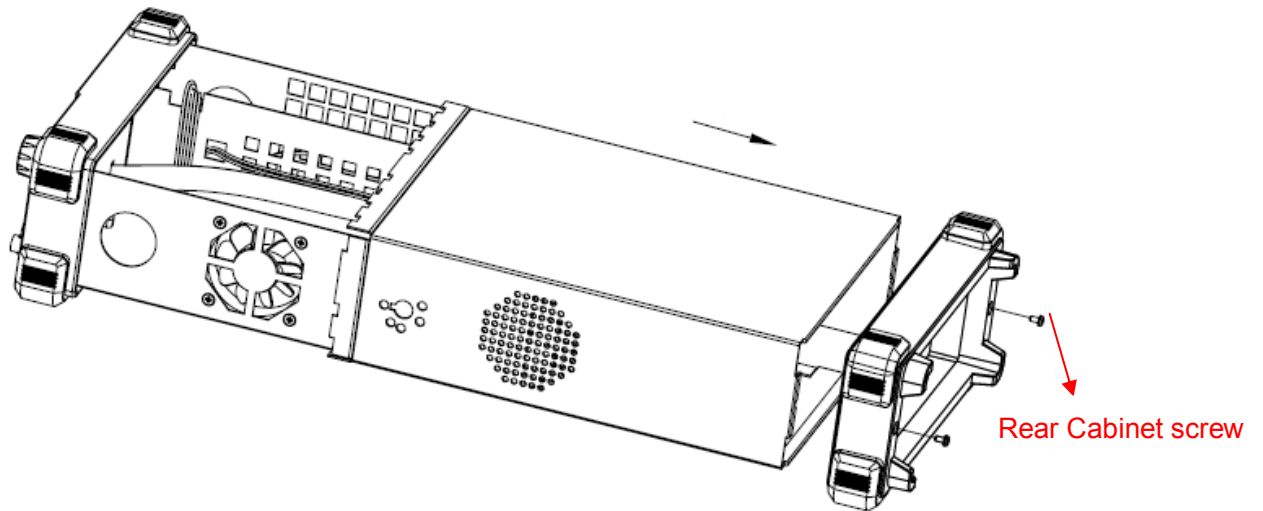

Table 4-3 Removing the Metal Shell and Rear Cabinet

Removing steps:

1. Remove the two screws from the rear cabinet of the generator using a PH2 phillips screwdriver.
2. Remove the rear cabinet.
3. Remove the metal shell carefully from the main body to avoid being scratched.

To install the metal shell and rear cabinet, please operate as the reverse steps.

Removing the Front Cabinet

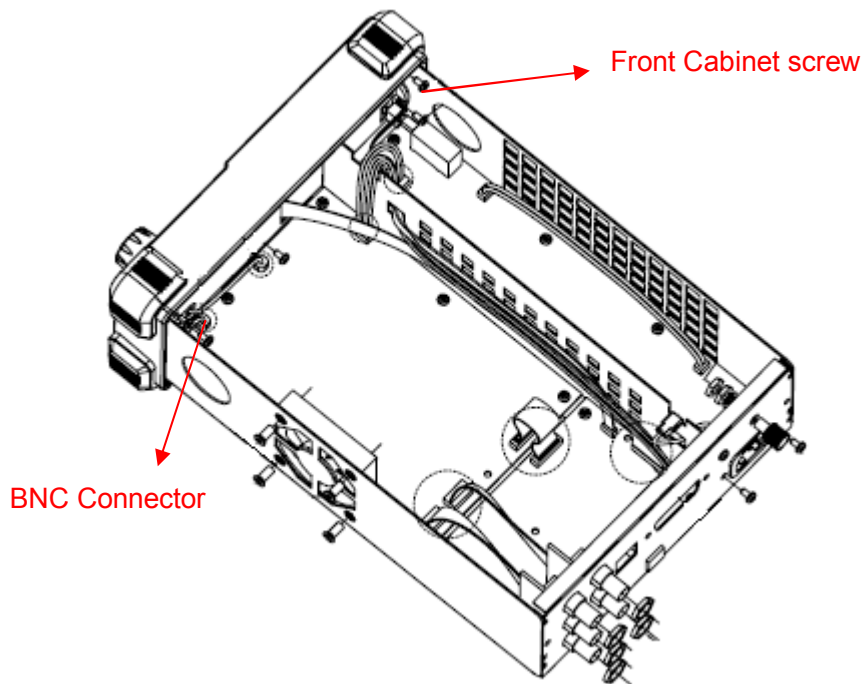

Table 4-4 Removing the Front Cabinet

Removing steps:

1. Remove the four front cabinet screws using the PH2 screwdriver.
2. Firmly pull up the two screws connected to the main board from the front panel BNC connectors.
3. Disconnect the display module cable and the USB module cable from the main board.
4. Separate the front cabinet from the main body of the generator.

To install the front cabinet, please operate as the reverse steps.

Removing the Display Module

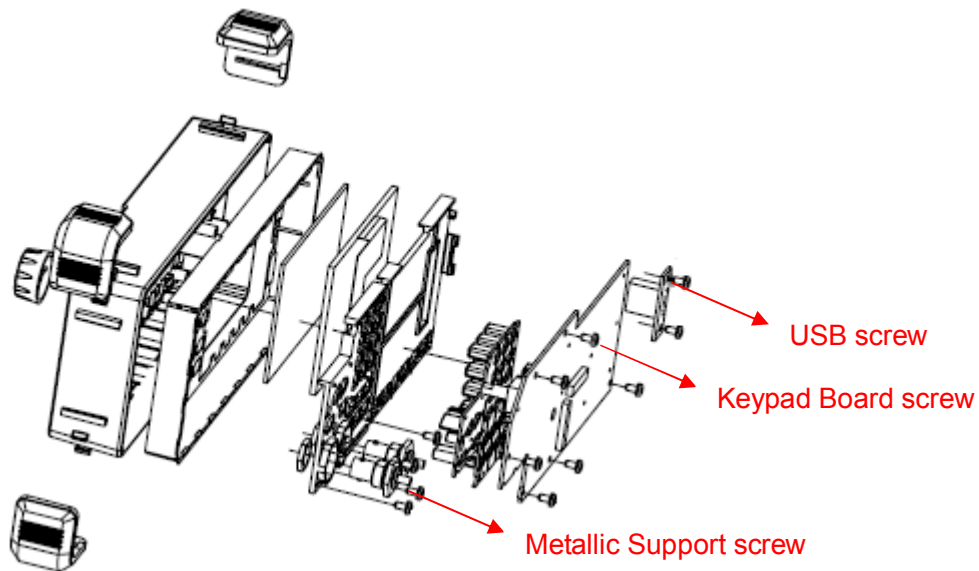

Table 4-5 Removing the display module screws

Removing steps:

1. Remove the six screws fixed the keypad circuit board using the PH2 screw driver.
2. Remove the two screws fixed the USB module using the PH2 screwdriver.
3. Remove the four screws fixed the metallic support using the PH2 screwdriver.
4. Remove the keypad circuit board, silica gel soft keypad, metallic support and LCD screen from the front cabinet in sequence.
5. Remove the front cabinet universal knob by firmly pull it out.

To install the display module, please operate as the reverse steps.

Removing the Main Body

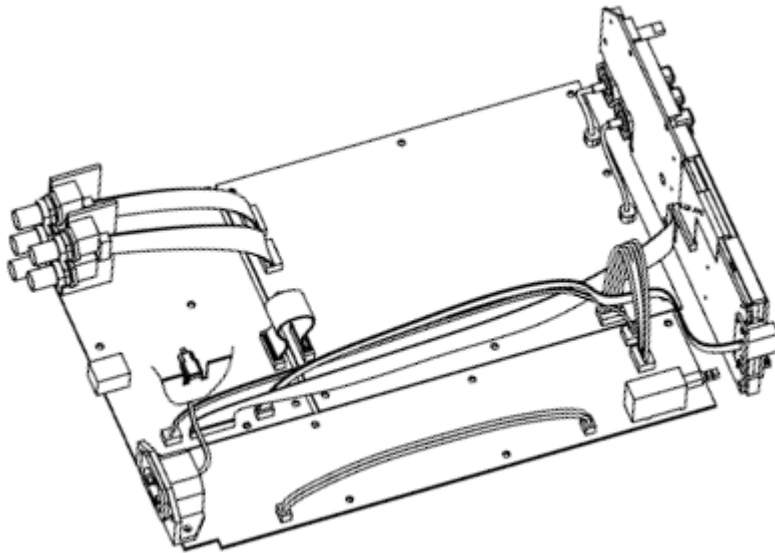

Table 4-6 Disconnecting all the cables

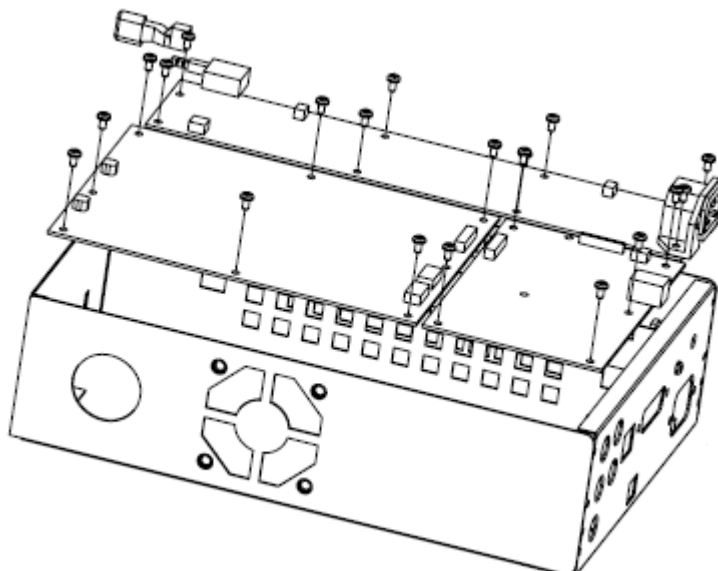

Table 4-7 Removing all the screws

Removing steps:

1. Disconnect all cables from the main board and power supply board.
2. Remove all the 20 screws fixed the main board and power supply board using a the PH2 screwdriver.
3. Separate the main board and power supply board carefully from the main body of the generator to avoid being scratched by the sharp metal edge.

To install the main body, please operate as the reverse steps.

Troubleshooting

The internal structure of the generator consists of main board, channel board and power supply board, and they are linked through cables or connectors. This chapter explains the main checking procedures for these three boards by measuring the rated test points on them, thus to help you decide the reason for the failure you encounter while operating SDG5000 series arbitrary waveform generator.

ESD Precautions

While performing any internal test of the generator, please refer to the following precautions to avoid damages to its internal modules or components result from ESD.

- Touch circuit boards by the edges as possible as you can.
- Reduce handling of static-sensitive modules when necessary.
- Wear a grounded antistatic wrist strap to insulate the static voltage from your body while touching these modules.
- Operate static-sensitive modules only at static-free areas. Avoid handling modules in areas that allow anything capable of generating or holding a static charge.

Required Equipments

The equipments listed in the table are required to troubleshoot the generator.

Table 5-1 Required equipments

Equipment	Critical Specifications	Example
Digital Multimeter	Accuracy $\pm 0.05\%$ 1 mV resolution	Agilent 34401A
Oscilloscope	200MHz Bandwidth	DSOX3024A

Channel Board Drawing

Channel board is a kind of signal conditioning board for output analog signal. It mainly works on the adjusting of signal parameters such as frequency, amplitude. Please refer to the following drawing to quickly locate the test points on the channel board for easy resolution of the failures you encounter.

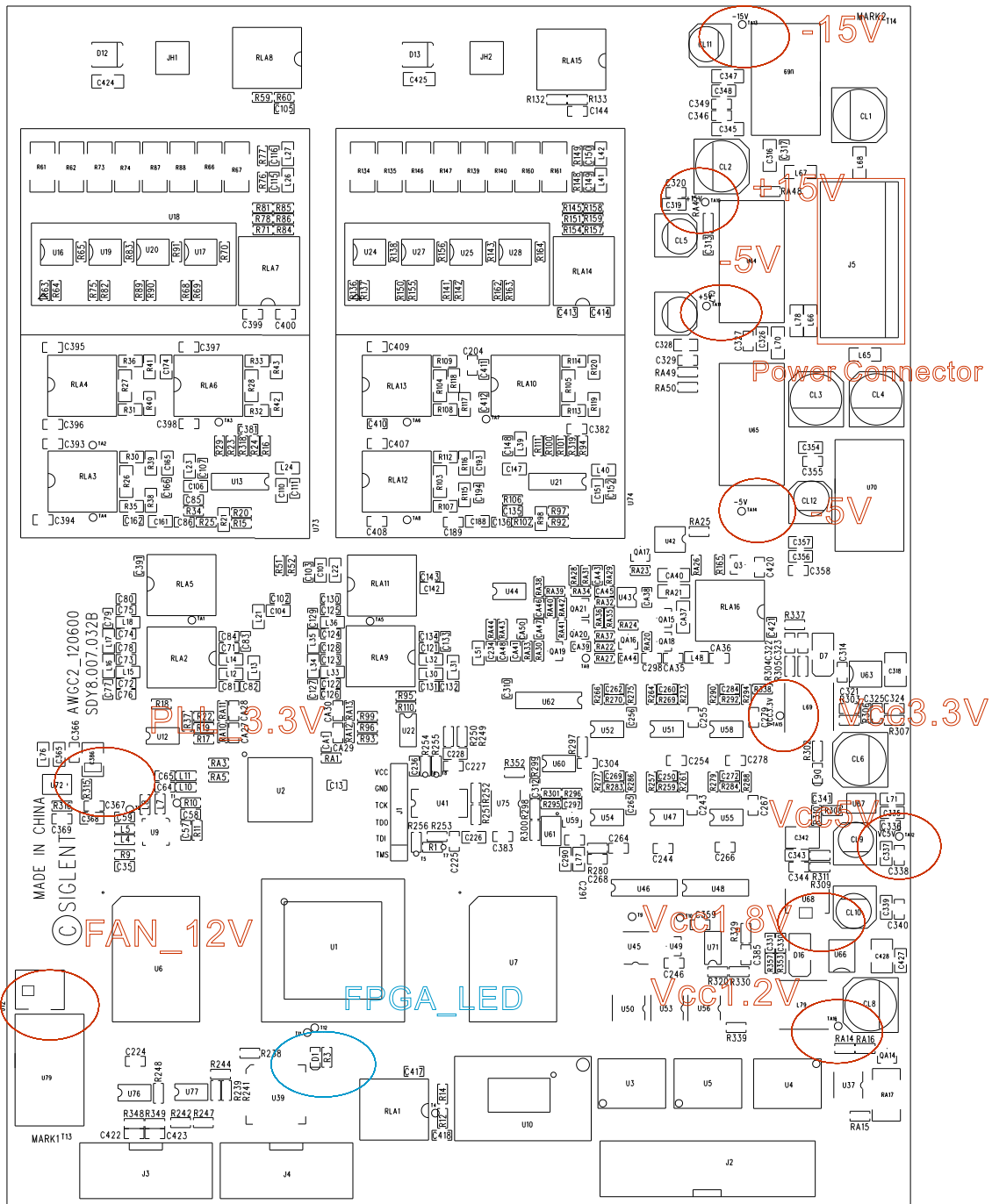

Main Board Drawing

Main board is used to control and manage the whole internal system of the generator. It completes the GUI function, controlling and configuration function for channel board as well as man-machine interaction. Please refer to the following drawing to quickly locate these test points on the main board for easy resolution of the failures you encounter.

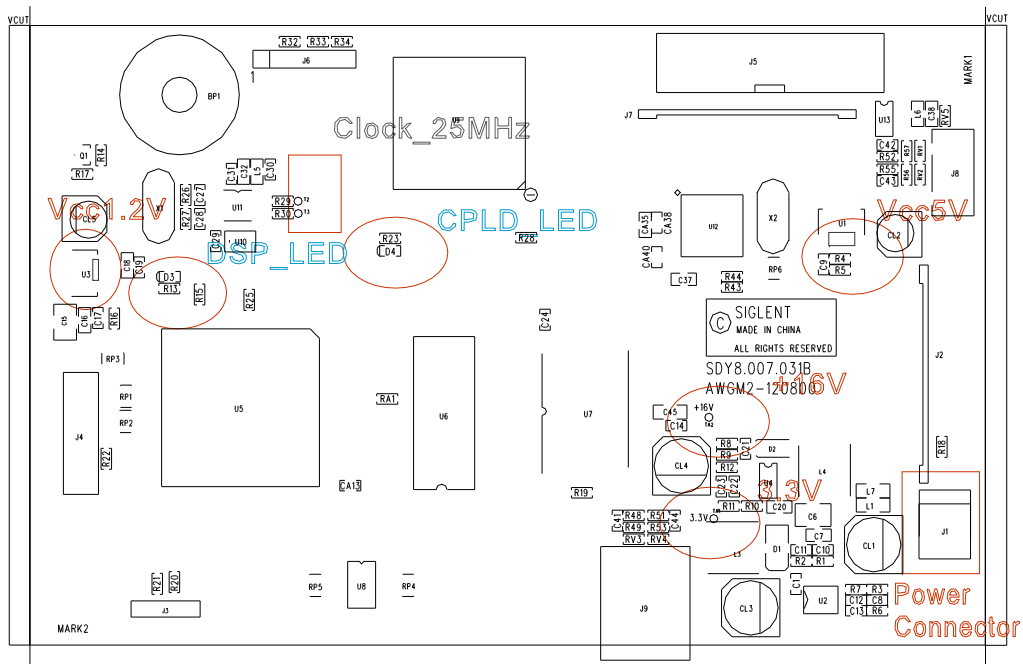

Check the Power Supply

There are two power connectors through which the channel board and main board can be supplied electricity. For the channel board, there are four voltage test points on its power connector. For the main board, there is one test point.

Before performing the power supply testing procedure, please make sure that the generator is grounded correctly through the protective lead of the power cord. Take care not to touch or even disassemble the power supply module without any safety precautions, or you may probably suffer from electric shock or burn. Here are procedures for testing the power supply:

1. Disconnect the power cord of the generator and then check whether the fuse has been burnt out.
2. Remove metal shell of the generator using a driver, and then disconnect the power connector connected to the main board.
3. Focus on the Power Connector for channel board, which contains 6 pins from Pin1 to Pin6. Since two of the six pins are ground wire, you can test the other four pins that are marked with blue, yellow, red and white to check whether the voltage value is within the corresponding specified range using a digital multimeter. The voltage parameters to be tested are listed in table below:

Table 5-2 Test voltages for the channel board power connector

Voltage value	Pins	Error limit
15.5V	VH+(red)	±5%
-16.5V	VH-(white)	±5%
5.5V	VL+(yellow)	±5%
-6.5V	VL-(blue)	±5%

Table 5-3 Test voltage for the main board power connector

Voltage value	Pins	Error limit
6.5V	VH+(red)	±5%

If each tested voltage value is within the corresponding spec range referring to the table above, then the power supply works normally. Otherwise, it proves to be faulted, please return it to the factory to have it repaired or contact SIGLENT.

Note: *The main power supply provides an input fuse to protect against the danger of fire in the event of a failure of the power supply circuitry. However, this fuse will not fail ("open" or "blow") in normal power supply operation except that a significant overload occurs. Replace the entire main power supply assembly if the input fuse fails.*

Check the Channel Board

If you want to remove the main board from the metal shelf inside the generator, you'd better place it on a clean, insulated mat. In addition, to avoid some chips or components on the main board being damaged for overheating, it is essential to cool the main board whenever possible using a fan. Here are procedures for testing the main board:

1. Several kinds of connectors including Fan Connector, Power Connector and Keypad Connector are located on the main board. Check if all these connectors are connected properly.
2. Make sure that the connectors on the channel board are properly connected, then connect the generator to AC power and turn it on. Check if the voltage values at all test points are within the spec range using a digital multimeter. The voltage parameters to be tested are listed in table below:

Voltage Checking

Test the voltage points on the channel board in the table below. If each tested voltage value is within the corresponding spec range referring to the table above, then the main board works normally. Otherwise, it proves to be faulted, please return it to the factory to have it repaired or contact SIGLENT.

Table 5-3 Test voltages of the channel board

Test point	Voltage value	Error limit
+15V	+15V	±5%
-15V	-15V	±5%
-5V	-5V	±5%
+5V	+5V	±5%
VCC3.3V	+3.3V	±5%
VCC5V	+5V	±5%
VCC1.8V	+1.8V	±5%
VCC1.2V	+1.2V	±5%
FAN_12V	+12V	±5%
PLL_3.3V	+3.3V	±5%

FPGA Checking

To check if the FPGA works normally, please look at the test point marked with FPGA_LED on the channel board drawing. The LED light twinkles at the frequency of 1Hz in normal case, if it can not be lighted or twinkles at incorrect frequency, then the FPGA may be faulted.

Check the Main Board

If you want to remove the main board from the metal shelf inside the generator, you'd better place it on a clean, insulated mat. In addition, to avoid some chips or components on the main board being damaged for overheating, it is essential to cool the main board whenever possible using a fan. Here are procedures for testing the main board:

1. Several kinds of connectors including Fan Connector, Power Connector and Keypad Connector are located on the main board. Check if all these connectors are connected properly.
2. Make sure that the connectors on the main board are properly connected, then connect the generator to AC power and turn it on. Check if the voltage values at all test points are within the spec range using a digital multimeter. The voltage parameters to be tested are listed in table below:

Voltage Checking

Test the voltage points on the main board in the table below. If each tested voltage value is within the corresponding spec range referring to the table above, then the main board works normally. Otherwise, it proves to be faulted, please return it to the factory to have it repaired or contact SIGLENT.

Table 5-4 Test voltages of the main board

Test point	Voltage value	Error limit
+16V	+16V	±5%
3.3V	+3.3V	±5%
VCC5V	+5V	±5%
VCC1.2V	+1.2V	±5%

Mainboard Clock Checking

Mainboard clock is the internal system clock of the generator. To verify if the clock on the main board works normally, please test the clock frequency listed below using an oscilloscope.

Test point	Frequency	Stability
Clock_25MHz	25MHz	±50ppm

DSP/CPLD Checking

DSP and CPLD respectively represent the main control chip and programmable logic device of the main board. Only when the corresponding codes loaded successfully, can the two chips work normally.

Look at the DSP_LED/CPLD_LED light on the main board, which indicates the working state of DSP/CPLD chip. If the light turns on, then the corresponding codes have been loaded successfully and the chip is in good working state. Otherwise, there may be failure within it.

Quick Guide for General Failures

The general hardware failures are described in the following. Reading the following information can help you quickly handle some easy hardware failures with more convenience.

1. No start-up after pressing the Power button:
 - (1) Check if the power cord is correctly connected.
 - (2) Check if the power button is usable.
 - (3) Check whether the fuse has been burnt out. If the fuse needs to be changed, please contact SIGLENT as soon as possible and return the instrument to the factory to have it repaired by qualified personnel.
 - (4) Check if the power connector is properly connected to the main board.
 - (5) If the instrument still does not work normally, please contact SIGLENT.

2. The instrument starts up with a dark screen:
 - (1) Check if the power connector is properly connected to the main board.
 - (2) Test if the voltages on the test points marked “-5V” and “LED_ANODE” are within the spec range.
 - (3) If the instrument still does not work normally, please contact SIGLENT.

3. No response after pressing any button or abnormal display of the screen:
 - (1) Check if the two end of the connector between the keypad circuit board and the main board is properly connected.
 - (2) If the instrument still does not work normally, please contact SIGLENT.

Maintenance

Maintain Summary

SIGLENT warrants that the products it manufactures and sells are free from defects in materials and workmanship for a period of three years from the date of shipment from an authorized **SIGLENT** distributor. If a product or CRT proves defective within the respective period, **SIGLENT** will provide repair or replacement as described in the complete warranty statement.

To arrange for service or obtain a copy of the complete warranty statement, please contact your nearest **SIGLENT** sales and service office.

Except that as provided in this summary or the applicable warranty Statement, **SIGLENT** makes no warranty of any kind, express or implied, including without limitation the implied warranties of merchantability and fitness for a particular purpose. In no case shall **SIGLENT** be liable for indirect, special or consequential damages.

Repackaging for Shipment

If the unit needs to be shipped to **SIGLENT** for service or repair, be sure to:

1. Attach a tag to the unit identifying the owner and indicating the required service or repair.
2. Place the unit in its original container with appropriate packaging material for shipping.
3. Secure the container with strong tape or metal bands.

If the original shipping container is not available, place your unit in a container which will ensure at least 4 inches of compressible packaging material around all sides for the instrument. Use static-free packaging materials to avoid additional damage to your unit.

Contact SIGLENT

SIGLENT TECHNOLOGIES CO., LTD

Address: 3/F, building NO.4, Antongda Industrial Zone, 3rd Liuxian
Road, Bao'an District, Shenzhen, P.R.China

Tel: 0086-755-3661 5186

E-mail: sales@siglent.com

<http://www.siglent.com>